

Proceedings of the  
Merck Young Chemists' Symposium  
XXIII edition

**Edited by:** I. Arduino, C. Bonfio, M. Bonomo, M. Da Pian, A. Dall'Anese, I. Fierri, A. M. Fiore, A. Marotta, M. Mendolicchio, C. M. Montone, E. Paone, F. Pizzetti, A. Polo, L. Rivoira, A. Rossetti, I. Romeo, M. Sambucci, C. Sergi, S. Tortorella, F. Vincenti.

Copyright© 2024 Società Chimica Italiana, Viale Liegi 48C, 00198 - Roma  
ISBN: 978-88-94952-50-6



Welcome to the 23<sup>rd</sup> edition of the Merck Young Chemists' Symposium (MYCS), formerly also known as SAYCS and MEYCS. This international conference is organized by the Young Group of Società Chimica Italiana (SCI Giovani) and the National Interuniversity Consortium of Materials Science and Technology (INSTM) with the financial support from Merck and several other sponsors, that you will meet during the conference.

The symposium covers all the disciplines of Chemistry, aiming to connect young researchers, inspire new ideas, and potentially trigger new collaborations. With the contributions of our five invited plenary speakers, and the international environment guaranteed by the presence of people coming from different countries, we truly hope that you will all enjoy this great event with us. We have worked hard to organize this meeting with 230 participants, prioritizing high-level scientific topics and other themes of crucial importance in our modern society. Thank you for the great trust shown towards SCI Giovani, Merck and all our supporters. Enjoy the conference and have a nice stay with us!

Marta Da Pian

*SCI Giovani Coordinator*

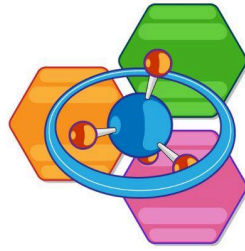

**MYCS**  
**2024**

Scientific and Organizing Committee

I. Arduino	E. Paone
C. Bonfio	F. Pizzetti
M. Bonomo	A. Polo
M. Da Pian	L. Rivoira
A. Dall'Anese	B. Rossetti
I. Fierri	I. Romeo
A.M. Fiore	M. Sambucci
A. Marotta	C. Sergi
M. Mendolicchio	S. Tortorella
C.M. Montone	F. Vincenti

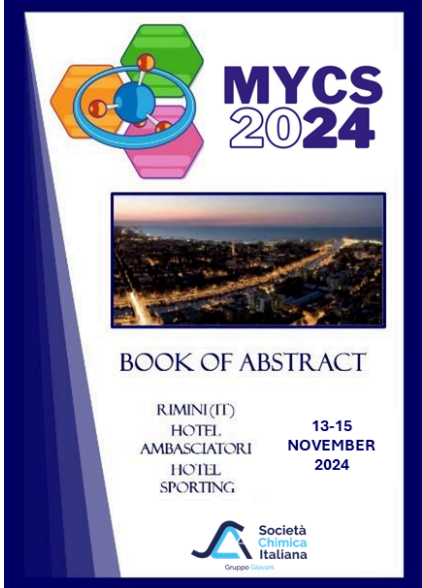
	How to cite your work
	<p>All the scientific contributions of the symposium are collected in this international volume with ISBN code.</p> <p>You can cite your work as follows:  N. Surname, N. Surname, g and N. Surname, &lt;Abstract title&gt;, in Proceedings of the Merck Young Chemist's Symposium 2023, XXII Ed. I. Arduino, C. Bonfio, M. Bonomo, M. Da Pian, A. Dall'Anese, I. Fierri, A. M. Fiore, A. Marotta, M. Mendolicchio, C. M. Montone, E. Paone, F. Pizzetti, A. Polo, L. Rivoira, A. Rossetti, I. Romeo, M. Sambucci, C. Sergi, S. Tortorella, F. Vincenti.  ISBN: 978-88-94952-50-6, 230, 2024, Rome.</p>

---

## Index

Plenary talks	5
Oral presentations	11
Flash communications	116
Poster presentations	181
Levi Award	212
Sponsors talks	215
List of participants	222

---

## Plenary talks

PL01 – Hendrik V. Schröder (Robert Bosch GmbH)

PL02 – Laura Aliotta (UniPI)

PL03 – Silvia Marchesan (UniTS)

PL04 – Elena Lenci (UniFI)

PL05 – Stefano Salmaso (UniPD)

---

## PL01

### Walking the tightrope: academia, industry, or somewhere in between

Hendrik V. Schröder<sup>a</sup>

<sup>a</sup> Robert Bosch GmbH, Stuttgart D-70469, Germany

E-mail: [hendrik.v.schroeder@gmail.com](mailto:hendrik.v.schroeder@gmail.com)

This talk will address (STEM) students at the Bachelor's, Master's, or PhD level who are thinking about their next steps towards developing a career—a career that should make (you!) happy in the long run. When is the right time to switch to industry? Can I stay in academia? Is becoming a postdoc a good option for me? What is the right work-life balance at an early-career stage?

In this talk, we will address these and other questions through open discussions. The first part of the talk gives an overview of my journey how I became a R&D teamlead in industry, including my previous stages in academic research. During my doctorate at FU Berlin (Germany) and my postdoc at Princeton University (NJ, USA) my research focused on organic chemistry, with a particular emphasis on molecules featuring mechanically interlocked structures. Following that, we will discuss principles that I have found immensely valuable for managing the ups and downs of establishing a research career in its early stages. Lastly, we will take a look behind the scenes and illustrate what daily life in industrial R&D entails and highlight general skills—beyond expertise in a particular field—which are crucial to master from a company's perspective.

Overall, this presentation aims to offer firsthand insights into a pivotal stage of career development. By examining the different options available and emphasizing personal fulfillment, attendees will be better prepared to make informed decisions that lead to a rewarding and satisfying career in academia and industry.



**Figure 1:** Early-career researchers often face delicate balances between work and personal well-being, between advancing your career and managing family responsibilities, and between meeting the needs of others and your own.

---

## PL02

### How can Agro-Industrial Wastes be turned into a resources? Examples of Sustainable Biocomposites

Laura Aliotta<sup>a,b</sup>, Vito Gigante<sup>a,b</sup>, Bianca Dal Pont<sup>a,b</sup>, Maria Beatrice Coltelli<sup>a,b</sup>, and Andrea Lazzeri<sup>a,b</sup>

<sup>a</sup> *Department of Civili and Industrial Engineering, University of Pisa, Largo Lucio Lazzarino 1, 56122 Pisa, Italy*

<sup>b</sup> *National Interuniversity Consortium of Material Science and Technology (INSTM), Via Giusti 9, 50121 Florence, Italy*

E-mail: [laura.aliotta@unipi.it](mailto:laura.aliotta@unipi.it)

Agro-industrial wastes valorization represent a significant challenge, but they also offer an untapped opportunity for creating sustainable resources. This lecture explores innovative approaches to converting waste into valuable materials, focusing on the development of sustainable biocomposites. By utilizing renewable and biodegradable components, these biocomposites not only reduce environmental impact but also offer enhanced properties suitable for a wide range of applications.

Through case studies, the discussion will highlight how these waste-derived materials can be transformed into appealing products, contributing to a circular economy and promoting sustainability in various sectors.

It will be emphasized how the adoption of local available wastes, allows the creation of local circular economy pathways. Some examples that will be illustrated in the lecture will be the use of volcanic ash as fertilizing filler for agriculture items [1], the valorization of hazelnut shell powder (HSP) as filler for aesthetic 3D printed items for design application [2], the use of cellulosic fibers for increasing the thermal stability of biobased matrices [3] and many others.

[1] L. Aliotta, V. Gigante and A. Lazzeri. Sustainable Materials and Technologies. (2023) 37, e00660.

[2] L. Aliotta, C. Sergi, B. Dal Pont, M.B. Coltelli, V. Gigante and A. Lazzeri. (2024) Materials Today Sustainability, 100780

[3] L. Aliotta, M. Gasenge, V. Gigante and A. Lazzeri. (2022). Polymers, 14 (21), 4499.

---

## PL03

### Diving Down the Rabbit Hole of Heterochiral Peptides

Silvia Marchesan<sup>a</sup>

<sup>a</sup> Department of Chemical and Pharmaceutical Sciences, Università degli Studi di Trieste,  
Via Giorgieri 1, 34127-Trieste, Italy

E-mail: [smarchesan@units.it](mailto:smarchesan@units.it)

*“Alice: Would you tell me, please, which way I ought to go from here?”*

*The Cheshire Cat: That depends a good deal on where you want to get to.*

*Alice: I don't much care where.*

*The Cheshire Cat: Then it doesn't much matter which way you go.*

*Alice: ...So long as I get somewhere.*

*The Cheshire Cat: Oh, you're sure to do that, if only you walk long enough.”*[1]

The scientific journey into heterochiral peptides' land started with a lot of wandering: from organic chemistry to molecular biology, from nanotechnology to materials science, from Europe to Australia, and back. The destination was unclear at the start of the journey, which was curiosity-driven, rather than carefully planned. It's being a great adventure, with many peculiar characters and new friends, a lot of learning lessons, some moments of despair and others of joy, with many parallels with Alice's Adventures in Wonderland by Lewis Carroll [1]. This lecture will describe the journey into heterochiral peptides' land [2-3] by a junior scientist that, like Alice, had to learn the rules (Figure 1) of this curious world not to get lost after diving down the rabbit's hole. This lecture aims to provide inspiration and motivation to junior scientists to dive with enthusiasm into their own journeys towards finding their professional identity.

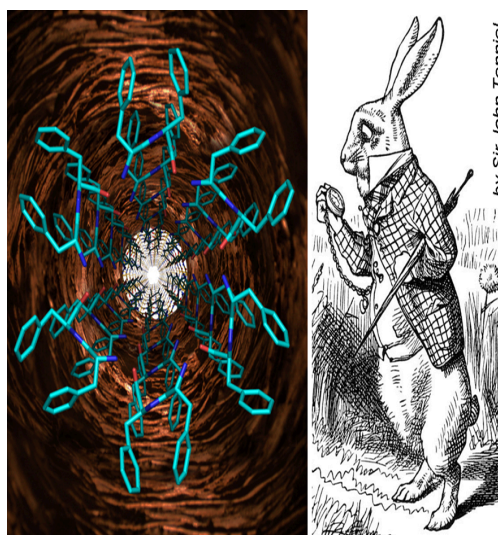

**Figure 1:** D-Phe-L-Phe [2] XRD structure as a rabbit hole's entry into Wonderland [1].

[1] Quotes from Alice's Adventures in Wonderland, by Lewis Carroll, 1865.

[2] S. Kralj, et al. ACS Nano 14 (2020), 16951-16961.

[3] S. Adorinni, et al. ACS Nano 18 (2024), 3011-3022.

## PL04

# Accessing new chemical space through Diversity-Oriented Synthesis and Chemoinformatics

Elena Lenci

*Dep. of Chemistry, University of Florence, Via della Lastruccia, 13, 50019 S. Fiorentino, Firenze, Italy*

*E-mail: [elena.lenci@unifi.it](mailto:elena.lenci@unifi.it)*

Small molecule libraries are a well-established tool for the identification of new hit compounds. Producing molecules with a high structural complexity and diversity is a crucial factor and still a struggling issue to increase the chance of a successful outcome in the screening campaign. In this context, Diversity-Oriented Synthesis (DOS) has proven to be very effective, as the compounds generated are structurally complex and differ not only for the appendages, but also for the molecular scaffold. In our group, we apply DOS principles starting from sugar- and amino-acid derived building blocks with the aim of developing skeletally complex scaffolds containing glyco- and/or peptidomimetic moieties [1]. Also, we combine DOS with chemoinformatics approaches to graphically visualize and/or predict the diversity and complexity of the compounds within the library [2]. Chemoinformatics tools are also used by our group to identify biologically-relevant regions of the chemical space that have been not yet explored, by performing a systematic characterization of all the compounds possessing precise chemotypes (such as bicyclic acetals, lactams, morpholines) [3].

Our efforts in this field have resulted in the discovery of several promising candidates, including ligands possessing a multi-targeting effect. Selected examples of our work are selective MMP inhibitors and integrin ligands as antitumoral compounds, BACE-1 inhibitors for the treatment of Alzheimer's Disease (AD) and 3CLPro inhibitors with potential application in the field of COVID-19 drug discovery.

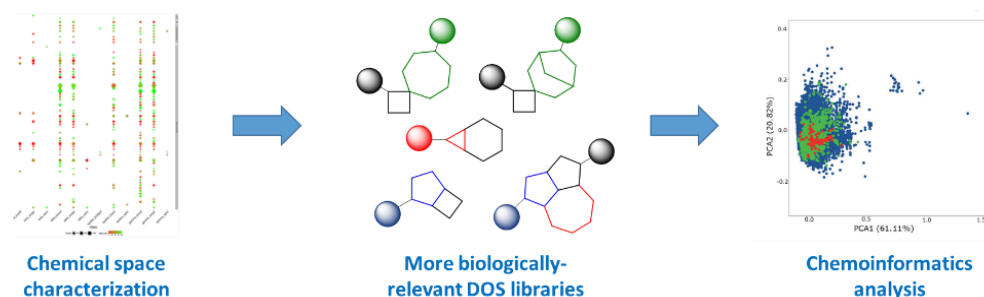

**Figure 1:** Synergistic approaches to obtain better chemical libraries for drug discovery.

[1] L. Baldini, E. Lenci, C. Faggi, and A. Trabocchi, *Org. Biomol. Chem.* 22 (2024) 2754-2763.

[2] E. Lenci, and A. Trabocchi, *Eur. J. Org. Chem.* 29 (2022) e202200575.

[3] (a) F. I. Saldivar-Gonzalez, E. Lenci, A. Trabocchi, and J. L. Medina-Franco, *RSC Advances* 9 (2019) 27105-27116; (b) M. Le Roch, J. Renalut, G. Argouarch, E. Lenci, A. Trabocchi, T. Roisnel, N. Gouault, and C. Lalli, *J. Org. Chem.* 89 (2024) 4932-4946.

## “Smart” drug nanocarriers with tailored core and surface

Stefano Salmaso

*Dep. of Pharmaceutical and Pharmacological Sciences, Un. of Padova, via F. Marzolo 5, 35131 Padova-Italy*

*E-mail: [stefano.salmaso@unipd.it](mailto:stefano.salmaso@unipd.it)*

The biopharmaceutical properties of nanocarriers designed for therapeutic delivery originate from the rational integration of components that determine their supramolecular characteristics. The core and surface features of these carriers, which are assembled through a bottom-up process, demand meticulous design of the individual components as well as the strategies for their assembly. These advanced systems have been conceptualized for the treatment of a variety of diseases by exploiting local microenvironments to control interactions with biological interfaces, drug release, clearance, and responsiveness to remote activation via external physical stimuli.

Our extensive research has focused on engineering the core of colloidal carriers specifically for anticancer drug delivery. Polyaminoacid-based self-assembling micelles were developed with a precisely designed amino acid composition to facilitate the delivery and controlled release of Doxorubicin to cancer cells. The composition of the micelles affects the core features and release of the drug under intracellular acid conditions. This strategy achieved higher antitumor activity compared to free Doxorubicin and demonstrated superior safety profiles relative to Caelyx® [1].

We developed a lipid nanoplatform for the oral delivery of the therapeutic peptide exenatide. The core of these lipid particles was engineered to improve peptide loading efficiency by integrating exenatide through a hydrophobic ion pairing approach. This sophisticated platform was assembled using a microfluidic process, ensuring uniformity and precision. The modulation of surface properties was crucial to endow mobility to the carrier within the mucus thus facilitating drug delivery across simulated intestinal 2D models.

Our research also encompasses "smart" surface engineering of therapeutic systems. Liposomes have been extensively studied by modifying their surface properties to enhance interaction with the biological milieu. By incorporating locally responsive polymers, cell penetration enhancers, and detachable masking agents, we have created a variety of multifunctional liposomes, each designed to interact logically with the specific microenvironments of their respective therapeutic targets. Particular emphasis has been placed on developing liposomes for anti-inflammatory drug delivery to the retina upon intravitreal administration for the treatment of age-related macular degeneration [2]. Additionally, we have enhanced the delivery of biotechnological drugs to bladder tumours following local instillation and we have also enhanced the intratumor delivery of anticancer agents upon parenteral administration compared to control PEGylated liposomes. Recently, we have also formulated lipid-based vesicles with enhanced RNA loading and more efficient intracellular delivery, pushing the boundaries of therapeutic delivery systems even further [3].

[1] Brunato S., Mastrotto F., Bellato F., Bastiancich C., Travanut A., Garofalo M., Mantovani G., Alexander C., Preat V., Salmaso S., Caliceti P. *J Control Release* 335 (2021) 21-37

[2] Al-Amin MD, Mastrotto F., Subrizi A., Sen M., Turunen T., Arango-Gonzalez B., Ueffing M., Malfanti A., Urtti A., Salmaso S., Caliceti P. *J Control Release* **354**, (2023) 323-336

[3] Malfanti A., Sami H., Balasso A., Marostica G., Arpac B., Mastrotto F., Mantovani G., Cola E., Anton M., Caliceti P., Ogris M., Salmaso S. 363 (2023) *J Control Release*. 101-113

---

## Oral presentations

- OR001 - ARMELI IAPICHINO Maria Teresa (UniCT)
- OR002 - BENETTIN Tommaso (UniMI)
- OR003 - GUGLIELMERO Luca (SNS)
- OR004 - GIULINI Nicolò (UniMiB)
- OR005 - IAPADRE Debora (UnivAQ)
- OR006 - ALFANO Antonella Ilenia (UniNA)
- OR007 - ANGELUCCI Andrea (UniROMA1)
- OR008 - CALLEGARI Camilla (UniPV)
- OR009 - GARBAGNOLI Martina (UniPV)
- OR010 - MARTINI Vittoria (UniPR)
- OR011 - PALOMBELLA Elena Teresa (UniBA)
- OR012 - NESPOLI Luca (UniMI)
- OR013 - BRUNETTI Leonardo (UniBA)
- OR014 - LEVERARO Silvia (UniFE)
- OR015 - BORGHI Federica (UniMORE)
- OR016 - CASTIGLIONE Davide (UniTO)
- OR017 - COMAS Iwasita Eisuke (UniTO)
- OR018 - COSENTINO Giuseppe (UniCT)
- OR019 - RIGHETTI Grazia Isa Carla (PoliMI)
- OR020 - SESSA Alessandra (UniSA)
- OR021 - ROSSINO Giacomo (UniPV)
- OR022 - DA FERMO Vanessa (UniCH)
- OR023 - MOTTA Daniele (UniTO)
- OR024 - SPERATI Valeria (PoliTO)
- OR025 - MILANESI Matteo (PoliTO)
- OR026 - MASSARO Arianna (UniNA)
- OR027 - ORECCHIO Silvia (UniPA)
- OR028 - CERRATO Andrea (UniRoma1)
- OR029 - CROSTA Sara (PoliMi)
- OR030 - CORSETTI Samanta (UniCam)
- OR031 - SCHIANO Marica Erminia (UniNA)
- OR032 - ELISI Gian Marco (UniURB)
- OR033 - LA MONICA Gabriele (UniPA)
- OR034 - MOI Davide (UniCA)
- OR035 - BERNARDONI Bianca Laura (UniPI)
- OR036 - TEDESCHI Vincenzo (UniBA)
- OR037 - CIANI Rebecca (UniPA)

---

OR038 - RIVA Laura (PoliMI)  
OR039 - SANTANDREA Domenico (UniVE)  
OR040 - SPOTTI Matteo (UniMiB)  
OR041 - DI GIACOMO Stefano (UniCH)  
OR042 - SAETTA Clara (UniMiB)  
OR043 - FATTALINI Marco (UniMi)  
OR044 - LENZI Chiara (UniBO)  
OR045 - DEGERLI Simge Naz (UniMI)  
OR046 - CARIOSCIA Alessio (UnivAQ)  
OR047 - DI MATTEO Valentina (UniBO)  
OR048 - DI SANTE Manuele (UniBO)  
OR049 - GIAGU Gabriele (UniBO)  
OR050 - MARCONI Alessia (UniBO)  
OR051 - MARRA Sebastiano (UniNA)  
OR052 - CAVALLORO Valeria (UniPV)  
OR053 - SACCHI Francesca (UniMI)  
OR054 - MARCOLLI Giulia (PoliMI)  
OR055 - MARINACCIO Lorenza (UniCH)  
OR056 - CABONI Pietro (UniCA)  
OR057 - VEERAPURAM Lavanya (UniME)  
OR058 - BEDOGNI Federico (UniBO)  
OR059 - ROSSI Eleonora (UniBO)  
OR060 - CASOLI Lorenzo (UniToV)  
OR061 - SPANÒ Vanessa (UniCT)  
OR062 - FAGGIANO Antonio (UniSA)  
OR063 - CAU Costantino (UniSS)  
OR064 - COSTANZO Giuliana (UniCT)  
OR065 - FONTANA Anna (UniPV)  
OR066 - BARONE Simona (UniNA)  
OR067 - ANTONINI Giulia (UniMI)  
OR068 - CIMMINO Wanda (UniNA)  
OR069 - KALLIGOSFYRI Panagiota (UniNA)  
OR070 - MAURI Anna (USins)  
OR071 - MIGLIONE Antonella (UniNA)  
OR072 - TRAVAGLIANTE Gabriele (UniCT)  
OR073 - MASETTI Andrea (UniBO)  
OR074 - GRAPPA Rossella (UniNA)  
OR075 - ROMANO Susanna (UniROMA3)  
OR076 - RAIÀ Giovanna (UniPA)  
OR077 - VENEZIA Virginia (UniNA)

- 
- OR078 - ALCHERA Federica (UniTO)
  - OR079 - LEPORE Elison (UniCAM)
  - OR080 - FRATELLO Chiara (UniROMA1)
  - OR081 - MARRETTA Laura (UniPA)
  - OR082 - MERCORELLI Nicolò (UniBO)
  - OR083 - TIBONI Mattia (UniUrb)
  - OR084 - VITALI Valentina (UniFI)
  - OR085 - ZINEDDU Stefano (UniFI)
  - OR086 - BIAGINI Denise (UniPI) - Winner of CHIMICAPISCE contest  
(Invited Speaker)
  - OR087 - ALESSANDRONI Laura (UNICAM)
  - OR088 - GERI Andrea (UniFI)
  - OR089 - CLIMACO Immacolata (UniNA)
  - OR090 - DEL GIUDICE Daniele (UniEIN)
  - OR091 - SCORZONI Giorgia (UniBO)
  - OR092 - DACREMA Ivan (National Institute of Chemistry in Ljubljana)
  - OR093 - CASTI Federico (UniCA)
  - OR094 - DE NARDO Eugenio (PoliTO, IIT)
  - OR095 - PREVIATI Eleonora (PoliTO)
  - OR096 - REVIGLIO Chiara (UniTO)
  - OR097 - FRANZINI Marcello (UniTO)
  - OR098 - PASCULLI Donato (UniTO)
  - OR099 - MACHADO DE ALENCAR Daniel Augusto (UniTO)
  - OR100 - QUAGLIA Giulia (UniPG)
  - OR101 - QUARTA Valentina (UniPV)

## OR001

### Carbon nitride-based photocatalysts for the hydrogen production using actual water matrices

Maria Teresa Armeli Iapichino,<sup>a</sup> Salvatore Scirè<sup>a</sup>, Roberto Fiorenza<sup>a</sup>, Joaquim L. Faria<sup>b</sup> and Maria José Sampaio<sup>b</sup>

<sup>a</sup>Department Chemical Science, University of Catania, Viale A. Doria, 95125-Catania, Italy

<sup>b</sup>Faculty of Engineering, University of Porto, Rua Dr. Roberto Frias, Porto, 4200-465, Portugal E-mail: [maria.armeliapichino@phd.unict.it](mailto:maria.armeliapichino@phd.unict.it)

The photocatalytic hydrogen production is present in top ten emerging technologies in chemistry. In this work, it is showed a photocatalytic comparison with different water matrices (ultrapure, seawater and wastewater) using g-C<sub>3</sub>N<sub>4</sub>-based materials. The use of seawater appears as a promising solution to produce H<sub>2</sub>, owing to its abundance on Earth and since it can be a source of electrons and protons [1]. The use of wastewater can be also an alternative using organic matter present in this polluted water. The focus of this work was to study the performance of graphitic carbon nitride (g-C<sub>3</sub>N<sub>4</sub>)-based catalysts synthesized by using different precursors (Melamine, Dicyanamide and Urea) [2]. The photocatalytic efficiency of the developed photocatalysts was examined using water solutions containing glucose as sacrificial agent. The photocatalyst showing the best results for H<sub>2</sub> production (Pt/g-C<sub>3</sub>N<sub>4</sub>) was tested as tested both in powder form and when immobilized as a film. Fig.1 shows that using immobilized Pt/g-C<sub>3</sub>N<sub>4</sub> and actual water matrices as water source higher amount of H<sub>2</sub> production is achieved compared with ultrapure water, suggesting that the organic species commonly presents in actual waters may act as active electron donors. These results are promising for developing sustainable solutions for current issues as the energy production.

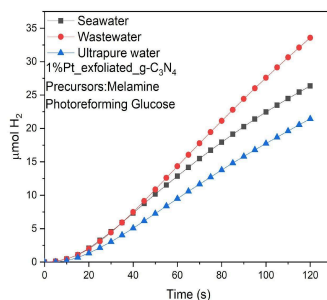

**Figure 1:** Photocatalytic H<sub>2</sub> production by immobilized Pt/g-C<sub>3</sub>N<sub>4</sub> (powder) using different water sources.

[1] R. A. Borges, M. F. Pedrosa, Y. A. Manrique, C. G. Silva, Adrián M.T. Silva, J. L. Faria and M. J. Sampaio, *Chem. Engineering Journal* 470 (2023) 1440066

[2] M.T. Armeli Iapichino, R. Fiorenza, V. Patamia, G. Floresta, A. Gulino and Salvatore Scirè, *Catalysis Communications* 187 (2024) 106850

**Acknowledgments:** This work was supported by national funds through FCT/MCTES (PIDDAC): LSRE-LCM, UIDB/50020/2020 (DOI: 10.54499/UIDP/50020/2020) and UIDP/50020/2020 (DOI: 10.54499/UIDP/50020/2020); and ALiCE, LA/P/0045/2020 (DOI: 10.54499/LA/P/0045/2020). M.J.S. acknowledges FCT funding under the Scientific Employment Stimulus - Institutional Call (CEECINST/00010/2021/CP1770/CT0011).

## Light-driven regioselective [2+2] cycloaddition of aryl-enones by Eosin Y

Tommaso Benettin, Simonetta Resta, Alessandra Puglisi, and Maurizio Benaglia

Dipartimento di Chimica, Università degli Studi di Milano, Via Golgi 19, Milano

E-mail: [tommaso.benettin@unimi.it](mailto:tommaso.benettin@unimi.it)

The use of light as energy source for organic synthesis has been emerged as a powerful tool to both explore new reactivity and have environmentally friendly processes [1]. In the same way, the development of flow chemistry in combination with light-driven processes allows to enhance the efficiency and the scalability of the reaction [2]. In this context, photocyclization of aryl-enones promoted by visible light in the presence of photocatalysts provides an innovative strategy for the synthesis of cycloalkanes, through radical intermediates [3]. After exploiting reactivity of different substituted aryl-enones to effort the [2+2] photocycloaddition by the use of Eosin Y as photocatalyst using visible light irradiation, we decided to transport this reaction under flow conditions in order to have a more efficient process. Different reaction conditions have been tested using symmetric and asymmetric substrates to achieve the bicycle products in good yields as a mixture of isomers. With our delight, for the symmetric aryl-enone, it was possible to find the conditions to selectively drive the cycloaddition towards one or the other isomer. Also, the best reaction conditions have been used in flow leading to reduced reaction time, increased productivity and selectivity towards the cis isomer preferentially, both for symmetric and asymmetric substrates. The cis isomer can be quantitatively converted into the trans isomer under basic conditions.

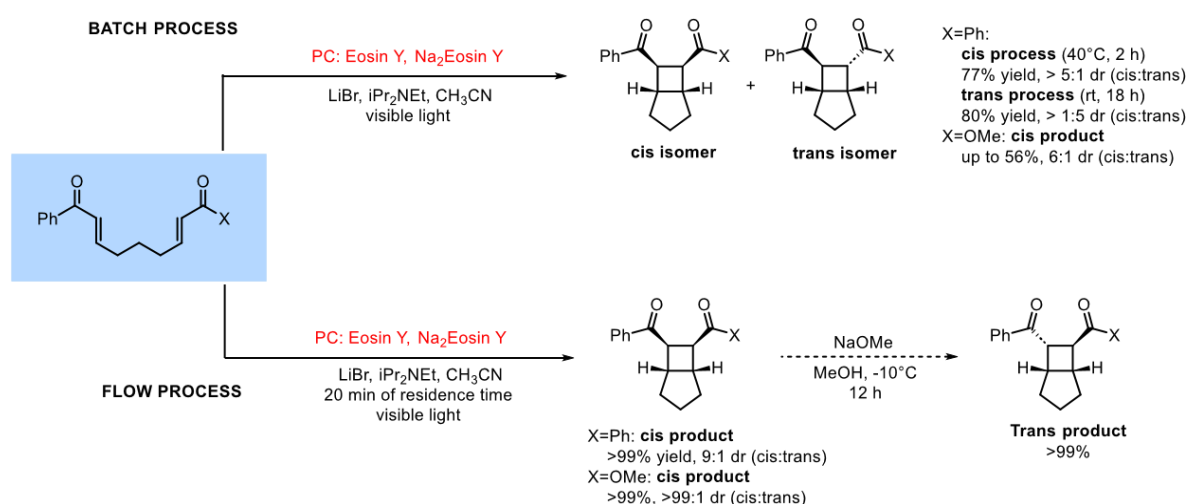

**Figure 1:** [2+2] photocycloaddition of aryl-enones in batch and in flow.

[1] M. Neumann, K. Zeitler, *Chem. Eur. J.* 19 (2013) 6950

[2] K. Jähnisch, V. Hessel, H. Löwe, M. Baerns, *Angew. Chem. Int. Ed.*, 43 (2004) 406–446

[3] F. Medici, S. Resta, P. Presenti, L. Caruso, A. Puglisi, L. Raimondi, S. Rossi, M. Benaglia, *Eur. J. Org. Chem.* 32 (2021) 4521

## Metal-EDTA and metal-IDA<sub>2</sub> ionic liquids catalyzed cycloaddition of CO<sub>2</sub> to epoxides

Luca Guglielmero,<sup>a</sup> Andrea Mezzetta,<sup>b</sup> Felicia D'Andrea,<sup>b</sup> Lorenzo Guazzelli,<sup>b</sup> and Christian Silvio Pomelli<sup>b</sup>

<sup>a</sup> Classe di Scienze, Scuola Normale Superiore, Piazza dei Cavalieri 7, 56126-Pisa, Italy

<sup>b</sup> Department of Pharmacy, Università di Pisa, Via Bonanno 33, 56126-Pisa, Italy

E-mail: [luca.guglielmero@sns.it](mailto:luca.guglielmero@sns.it)

The study of CO<sub>2</sub> based chemistry has been attracting a growing attention during the last decades because of the related greenhouse issues and, on the other hand, due to its abundance, low cost, and renewable nature as a C1 carbon source. The use of CO<sub>2</sub> as a starting material for the preparation of high value chemicals such as organic carbonates, represents a desirable and convenient application in the green chemistry frame.[1] Organic carbonates are generally proposed as environmentally friendly solvents, as starting material for the synthesis of polycarbonates, and as gasoline additives.[2] The use of ionic liquids (ILs) as homogeneous catalysts for the synthesis of cyclic carbonates has been proven successful in many literature papers. Parallely, the study of catalytic systems based on metal salts or combination of them and ILs has also provided noteworthy results.[3]

The use of ILs catalysts including metal complexes in their structures offers a promising approach for the preparation of novel catalytic systems for the CO<sub>2</sub> cycloaddition reaction (Figure 1). Despite this, at the best of our knowledge, this approach has been only marginally explored to date. Two series of ILs based on metal-EDTA and metal-iminodiacetate (IDA) complexes have been prepared and their catalytic performances over a panel of epoxides has been investigated. The effect of different metal cations and of the type of ligand on the catalytical activity has been assessed. Finally, the interactions between the catalyst, CO<sub>2</sub> and the epoxide have been computationally studied, revealing a noteworthy cooperative effect between the metal cation and a carboxylate group of the ligand throughout each step of the catalytic cycle.

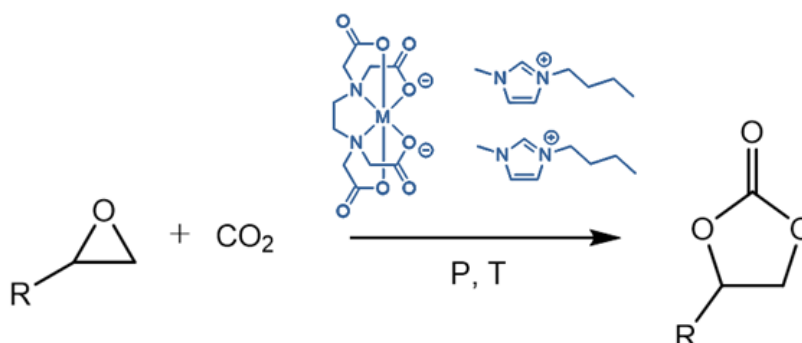

**Figure 1:** Schematic synthesis of cyclic carbonates.

[1] A. Rehman, F. Saleem, F. Javed, A. Ikhlaq, S. W. Ahmad, and A. Harvery, *Journal of Environmental Chemical Engineering* 9 (2021) 105113.

[2] L. Guglielmero, A. Mezzetta, C. S. Pomelli, C. Chiappe, and L. Guazzelli, *Journal of CO<sub>2</sub> utilization* 34 (2019) 437-445.

[3] D. Kim, Y. Moon, D. Ji, H. Kim, and D.H. Cho, *ACS Sustain. Chem. Eng.* 4 (2016), 4591-4600.

## Conjugated microporous polymers (CMPs) as heterogeneous catalysts for Suzuki-Miyaura reactions in water

Nicolò Giulini, Sara Mattiello, Carlo Santoro, and Luca Beverina<sup>a</sup>

<sup>a</sup> Dipartimento di Scienza dei Materiali, Università degli studi di Milano-Bicocca,  
Via Cozzi 55, 20126, Italia  
E-mail: [n.giulini@campus.unimib.it](mailto:n.giulini@campus.unimib.it)

Synthetic protocols for organic semiconductors often require large quantities of toxic and/or flammable organic solvents and involve reagents and byproducts harmful to health and the environment. The palladium-mediated Suzuki-Miyaura (SM) cross-coupling reaction is a cornerstone among these protocols. In recent years, the potential of exploiting the surfactant-enhanced (SE) approach has been demonstrated, enabling the SM reaction to be performed in water with the aid of a suitable surfactant (e.g., Kolliphor EL), thereby increasing the sustainability of the process [1,2]. This approach is now well-established for the synthesis of small organic molecular semiconductors and has also been proven effective for fabricating conjugated linear semiconducting polymers [3].

The presented work demonstrates the capability to synthesize three-dimensional conjugated microporous polymers (CMPs), such as poly(9,9-spirobifluorene-2,2',7,7'-benzothiadiazole) (PSBFBT, **Fig.1**), via the SE-SM coupling protocol. A complete chemical, spectroscopic, and morphological characterization will be presented and compared with that of the material obtained by standard literature methodologies. Inductively coupled plasma atomic emission spectroscopy (ICP-AES) investigation confirmed the presence of Pd species trapped in the final purified material. The embedded metal could be exploited as a catalyst in the SE-SM synthesis of small molecules. To this end, the application of PSBFBT as a heterogeneous catalyst for a phosphine-free, ppm-level palladium SM reaction in water will be discussed.

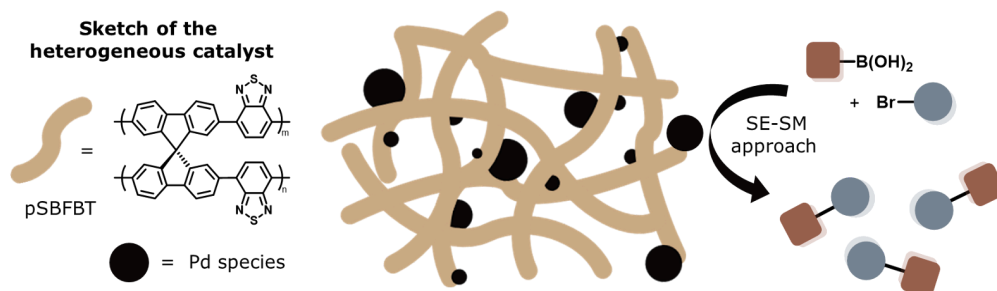

**Figure 1:** Chemical structure of pSBFBT and a sketch of its use as heterogeneous catalyst for phosphine-free SE-SM reactions.

[1] B.H. Lipshutz, S. Ghorai, M. Cortes-Clerget, *Chem. Eur. J.* 24 (2018) 6672–6695.

[2] S. Mattiello, M. Rooney, A. Sanzone, P. Brazzo, M. Sassi, L. Beverina, *Org. Lett.* 19 (2017) 654–657.

[3] A. Sanzone, A. Calascibetta, M. Monti, S. Mattiello, M. Sassi, F. Corsini, G. Griffini, M. Sommer, L. Beverina, *ACS Macro Lett.* 9 (2020) 1167–1171.

## New hydrogen bonding motifs for anion binding catalysis

Debora Iapadre,<sup>a</sup> Alessio Carioscia,<sup>a</sup> Jonathan Di Pietro,<sup>a</sup> Elena Incerto,<sup>a</sup> Fabio Pescioli,<sup>a</sup>  
and Armando Carlone<sup>a,b</sup>

<sup>a</sup> Dipartimento di Scienze Fisiche e Chimiche, Università degli Studi dell'Aquila, Via Vetoio, 67100, L'Aquila, Italia

<sup>b</sup> INSTM, Consorzio Nazionale per la Scienza e Tecnologia dei Materiali, RU L'Aquila, Italy  
E-mail: [debora.iapadre@student.univaq.it](mailto:debora.iapadre@student.univaq.it)

Inspired by nature, supramolecular catalysis exploits non-covalent interactions to accelerate chemical transformations [1]. Indeed, weak bond interactions has attracted great interest and in particular anionic bond plays an important role in the field of catalysis [2]. This type of catalysis can be accomplished using H-bonding, as well as halogen bonding, and chalcogen bonding. In each case, the binding of an anion is pivotal to promoting a chemical reaction in which ionic or ionizable substrates could be susceptible to nucleophilic attack. In this context, we aim to study the properties and catalytic performance of carbazole-triazoles, acting as receptors for anion based on 1,8-diaminocarbazole scaffold, which is well known for its anion-binding abilities [3]. A family of structurally related diaminocarbazole receptors has been prepared using a convergent, robust and high-yielding synthesis; their anion-binding properties have been evaluated in terms of binding constants toward different anions and catalytic activity has been tested in a benchmark reaction.

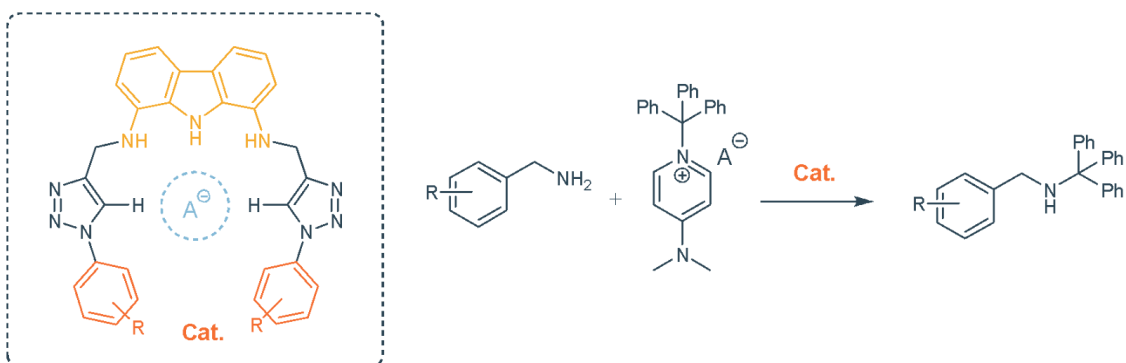

**Figure 1:** General structure of the receptors based on a 1,8-diaminocarbazole scaffold and catalytic system explored using them as a catalysts.

[1] R. Breslow; S. D. Dong, *Chem. Rev.* 98 (1998) 5, 1997-2012

[2] J. M. Ovian, P. Vojáčeková, E. N. Jacobsen, *Nature* 616 (2023) 84-89

[3] M. J. Chmielewski, M. Charon, J. Jurczak, *Org. Lett.* 6 (2004) 20, 3501–3504

## Multiphase photochemistry in flow mode via an integrated continuous stirred tank reactor (CSTR) approach

Antonella Ilenia Alfano,<sup>a,b</sup> Megan Smyth,<sup>c</sup> Scott Wharry,<sup>c</sup> Thomas S. Moody,<sup>c</sup> Manuel Nuño,<sup>d</sup> Chris Butters,<sup>d</sup> and Marcus Baumann<sup>a</sup>

<sup>a</sup> School of Chemistry, University College Dublin, Science Centre South, Dublin 4, Ireland

<sup>b</sup> Department of Pharmacy, University of Naples Federico II, Via Domenico Montesano 49, 80131-Naples

<sup>c</sup> Almac Sciences, Technology Department, Craigavon BT63 5QD, UK

<sup>d</sup> Vapourtec, Fornham St Genevieve, Bury St Edmunds, Suffolk, UK

E-mail: antonellailenia.alfano@unina.it

Photochemical reactions in flow are emerging transformations for the synthesis of building blocks and target compounds that are difficult to achieve *via* ground state chemistry [1]. While the flow chemistry gives to the reaction numerous advantages in term of better heat transfer, more uniform irradiation and unique control, the use of solids remains a big challenge due to the possible blockages of the narrow diameter tubes. A new photochemical CSTR system capable of handling solids in scaled continuous processes is presented [2]. High-power 365 nm UV-LEDs are integrated in these CSTRs containing an insoluble base that aids in generating pyrazolines *via* cycloaddition between alkenes and *in situ* generated diazo species. Contrary to reported batch methods product degradation *via* ring contraction to generate more stable cyclopropanes, is suppressed whilst generating gram quantities of spirocyclic  $\Delta^1$ -pyrazoline and  $\Delta^2$ -pyrazoline products. A library of 8 compounds was developed on two different scale, 2 and 10 mmol, generating grams of the final target compounds. We also integrate an extractive in-line work-up that would remove traces of inorganic materials and ensure isolation of clean pyrazoline products upon solvent evaporation only.

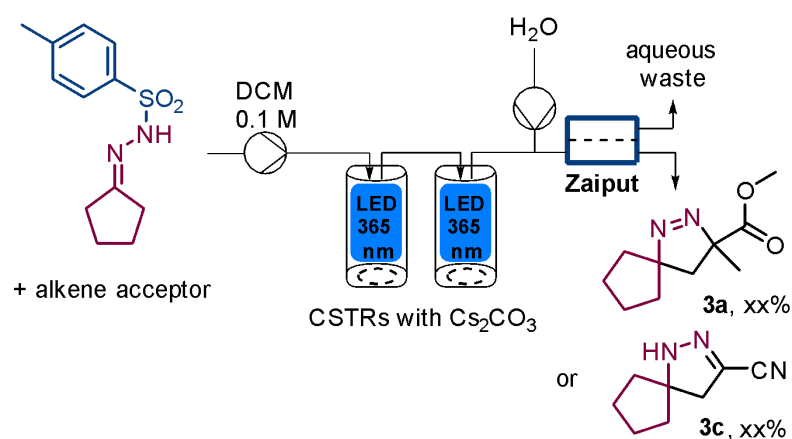

**Figure 1:** Photo-CSTR cascade with integrated in-line work up using Zaiput membrane technology.

[1] L. Buglioni, F. Raymenants, A. Slattery, S. Zondag, and T. Noël, *Chem. Rev.* 122 (2022) 2752-2906

[2] A. I. Alfano, M. Smyth, S. Wharry, T. Moody, M. Nuño, C. Butters, and M. Baumann, *Chem. Commun.* 60 (2024) 7037-7040

## Porphyrazines carrying externally *o*-carboranedithiolate groups as potential bimodal PDT/BNCT anticancer agents

Andrea Angelucci, Claudio Ercolani, and Maria Pia Donzello

Department of Chemistry, Sapienza University of Rome, P.le Aldo Moro 5, 00185-Rome, Italy

E-mail: [andrea.angelucci@uniroma1.it](mailto:andrea.angelucci@uniroma1.it)

In our previous extensive studies the synthesis, physicochemical properties and photoactivity as anticancer drugs in photodynamic therapy (PDT) [1] were reported of pentanuclear octa(2-pyridyl)tetrapyrzino porphyrazines complexes, carrying externally eight units of 1-thiolate-*m*-carborane (CBT) formulated as  $[\{Pd(CBT)_2\}_4Py_8TPyzPzM] \cdot xH_2O$ , where  $Py_8TPyzPz =$  tetrakis-2,3-[5,6-di(2-pyridyl)pyrazino]porphyrazine and  $M = Mg^{II}(H_2O), Zn^{II}, Pd^{II}$  (Figure 1A) [2]. The photosensitizer activity for the generation of singlet oxygen,  $^1O_2$ , the cytotoxic agent in PDT, was explored in DMF solution. These species have high quantum yield values ( $\Phi_\Delta = 0.6-0.7$ ) which are higher than those obtained for the parent  $[\{PdCl_2\}_4Py_8TPyzPzM]$ , and  $[Py_8TPyzPzM]$  complexes. Moreover, the presence of high boron content can open perspectives for their use in Boron Neutron Capture Therapy (BNCT), an experimental radiotherapy studied against aggressive and penetrating cancerous pathologies [3].

In an extension of our work on new TPyzPzs it was thought interesting to open additional perspectives of application in a bimodal anticancer therapy PDT/BNCT. For this purpose new homo/eteropentanuclear tetrapyrzino porphyrazines having externally four units of 1,2-dithiolate-*o*-carborane, formulated as  $[\{Pd(CBdT)\}_4Py_8TPyzPzM] \cdot xH_2O$  (CBdT = 1,2-dithiolate-*o*-carborane;  $M = Mg^{II}(H_2O), Zn^{II}, Pd^{II}$ ) (Figure 1B), have been synthesized and characterized. The photosensitizer activity for the generation of singlet oxygen was explored for the  $Zn^{II}$  and  $Mg^{II}$  complexes in DMF. The high  $\Phi_\Delta$  value obtained for the  $Zn^{II}$  macrocycle (0.58) falls within the range 0.4-0.7 observed for numerous phthalocyanines and  $Zn^{II}$  porphyrazines. These results qualify the  $Zn^{II}$  complex  $[\{Pd(CBdT)\}_4Py_8TPyzPzZn]$  as an excellent photosensitizer for the generation of singlet oxygen and in addition its high boron content suggests the possibility to be used as bimodal anticancer agent (PDT/BNCT).

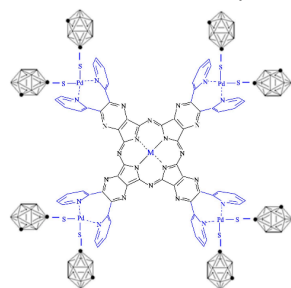

Figure 1A

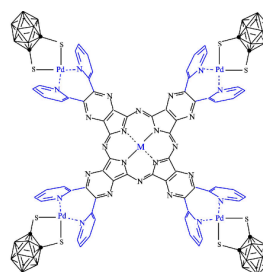

Figure 1B

[1] M. Ethirajan, Y. Chen, P. Joshi, and R. K. Pandey, *Chem. Soc. Rev.* 40 (2011) 340-362

[2] E. Viola, M. P. Donzello, S. Testani, G. Luccisano, M. L. Astolfi, C. Rizzoli, L. Cong, L. Mannina, C. Ercolani, and Karl M Kadish, *Inorg. Chem.* 58 (2019) 1120-1133

[3] R. J. Grams, W. L. Santos, I. R. Scorei, A. Abad-García, C. A. Rosenblum, A. Bitá, H. Cerecetto, C. Viñas, and M. A. Soriano-Ursúa, *Chem. Rev.* 124 (2024) 2441-2511

## Carbon nitride materials as green photocatalysts in C-H bonds functionalization processes

Camilla Callegari,<sup>a</sup> Giulia Draghi,<sup>a</sup> Sonia Zoltowska,<sup>b</sup> Paolo Giusto,<sup>b</sup> and Davide Revelli<sup>a</sup>

<sup>a</sup>Department of Chemistry, University of Pavia, Viale Taramelli 12, 27100 Pavia, Italy

<sup>b</sup>Max Planck Institute of Colloids and Interfaces, Am Mühlenberg 1, 14476 Potsdam, Germany

E-mail: [camilla.callegari01@universitadipavia.it](mailto:camilla.callegari01@universitadipavia.it)

Graphitic carbon nitride semiconductors are inexpensive and reusable photocatalysts, which are actively studied in organic synthesis. Such materials are widely appreciated for their capability to trigger single electron transfer (SET) processes with organic substrates upon irradiation with visible light. Such mechanism, however, limits the number of competent substrates to derivatives characterized by modest redox potentials, at any rate matching the redox potentials of the photocatalyst itself [1].

Much less explored is the possibility to directly functionalize (strong) C–H bonds in unactivated substrates. Herein, building upon a previously reported Minisci-type coupling involving aliphatic substrates and heteroarenes [1], we propose an innovative redox-neutral application of carbon nitride materials in a Giese reaction between ethers, amides, *etc.* (R–H) and electron-poor olefins (see Figure 1a). The preparative studies have been supplemented as well by mechanistic experiments, intended to elucidate the mechanism involved in the key C–H cleavage event in R–H, presumably involving a proton-coupled electron transfer (PCET) mechanism [2].

Furthermore, recalcitrant substrates have been successfully functionalized by implementing an unprecedented heterogeneous *indirect* hydrogen atom transfer process (*i*-HAT) [3]. In such reaction manifold, an additive is activated by the excited carbon nitride material and then takes care of C–H cleavage in the chosen substrate through the action of the photogenerated hydrogen abstractor **X<sup>•</sup>** (see figure 1b).

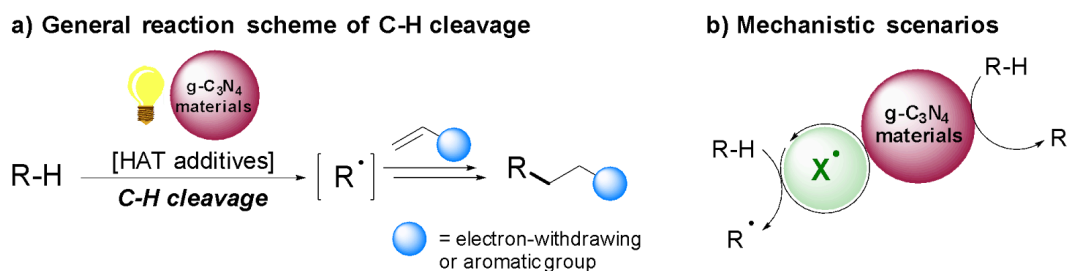

**Figure 1:** Carbon nitride materials as heterogeneous photocatalyst in C–H bonds functionalization: i) General reaction scheme; ii) Mechanistic scenarios.

Financial support through the HORIZON-EIC-2021-PATHFINDEROPEN-01 project CATART (GA 101046836) entitled “Reaction robot with intimate photocatalytic and separation functions in a 3-D network driven by artificial intelligence” is gratefully acknowledged.

[1] O. Savateev, J. Zhuang, *ChemPhotoChem* 8 (2024) e202300306

[2] X. Wu, X. Fan, S. Xie, I. Scodeller, X. Wen, D. Vangestel, J. Cheng, and B. Sels, *Nat. Commun.* 15 (2024) 4967

[3] L. Capaldo, and D. Ravelli *Eur. J. Org. Chem.* 2017 (2017) 2056–2071

## Development of a series of photoactivatable interferents of the HuR-RNA complex as novel potential anticancer agents

Martina Garbagnoli,<sup>a</sup> Giacomo Rossino,<sup>a</sup> Roberta Listro,<sup>a</sup> Melania Elettra Vaccari,<sup>b</sup> Stefano Protti,<sup>a</sup> Anna Tesei,<sup>b</sup> and Simona Collina<sup>a</sup>

<sup>a</sup> Department of Drug Sciences, University of Pavia, Viale Taramelli 12, 27100-Pavia, Italy

<sup>b</sup> Istituto Romagnolo per lo Studio dei Tumori Dino Amadori, Via Piero Maroncelli 40, 47014-Meldola, Italy  
E-mail: martina.garbagnoli01@universitadipavia.it

Photopharmacology is an innovative approach that combines the action of light with the therapeutic effect of exogenous agents. Specifically, some small molecules with photoactivatable portions can undergo photopharmacological events after light irradiation, changing their pharmacological activities [1]. This strategy represents a great opportunity in the field of the discovery of agents against cancer to overcome toxicity and selectivity issues of conventional chemotherapy [2]. Our research group has been studying RNA-binding proteins for a long time, specifically on finding new compounds able to interfere with the HuR-RNA complex [3]. A series of photoswitchable HuR ligands was designed decorating a previously identified HuR ligand with a photoisomerizable portion. In this work, the photoswitchable effect is based on the E/Z isomerization of the photoactivatable portion, constituted by azobenzenes and their heteroaromatic analogues (Figure 1). All new compounds were synthesized, and their kinetic conversion was investigated using UV and HPLC techniques. Further biological evaluations on breast cancer and glioblastoma cells were conducted to evaluate the biological effect of both isomeric forms of each compound.

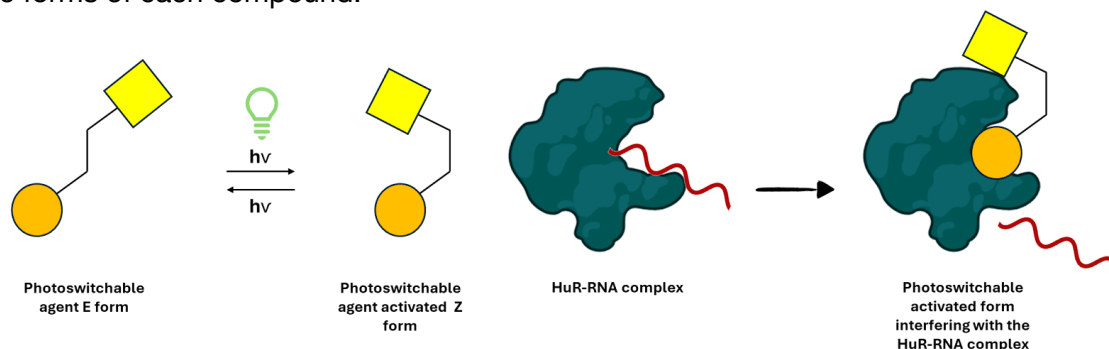

**Figure 1:** Photoactivatable compounds interfering with the HuR-RNA complex after their activation.

[1] M. J. Fuchter, *J. Med. Chem.* 63 (2020) 11436-11447

[2] P. Dunkel, and J. Ilaš, *Cancers (Basel)* 13 (2021) 3237

[3] S. Della Volpe, P. Linciano, E. Tumminelli, M. Amadio, I. Bonomo, W. A. M. Elgaher, S. Adam, A. K. H. Hirsch, F. M. Boeckler, F. Vasile, D. Rossi, and S. Collina, *Bioorg. Chem.* 116 (2021) 105305.

## Use of a traceless activating group in photocatalyzed HAT: the CO-HAcTive strategy

Vittoria Martini, Serena Abrami, Nicola Della Cà, and Luca Capaldo

Department of Chemistry, Life Sciences and Environmental Sustainability,  
University of Parma, Parco Area delle Scienze 11/A, 43124, Parma, Italy  
E-mail: [vittoria.martini@unipr.it](mailto:vittoria.martini@unipr.it)

In photocatalyzed hydrogen atom transfer (HAT) a suited photocatalyst absorbs a photon and cleaves homolytically an *aliphatic* C–H bond from an H-atom donor to produce the desired alkyl radical. However, this synthetic method faces two major limitations: regioselectivity and slow kinetics [1]. In the first case, the challenge lies in the ubiquitous presence of C–H bonds in organic molecules, so regioselectivity remains influenced by the stereoelectronic properties of the substrate, the chosen photocatalyst, and the potential use of additives [2]. To address the issue of slow kinetics, it is crucial to use substrates in superstoichiometric amounts, which is a considerable limitation for the adoption of HAT in late-stage functionalization reactions.

The CO-HAcTive strategy exploits the formyl group as a traceless activating group (TAG) to resolve both restraints and activate one specific C–H bond of the substrate. This TAG reacts faster than the alternative sites within the molecule and upon rapid fragmentation (decarbonylation) discloses the respective carbon-centred radical for the desired synthetic applications.

In detail, we adopted the Garner's Aldehyde (GA) as model substrate and the strategy allowed the creation of new C–C bonds via a Giese-type radical addition and SOMOphilic alkynylation (**Figure 1**). Once the oxazolidine ring is installed, it can be opened via acidic hydrolysis and transformed into the corresponding unnatural amino acid (UAA). The GA is a chiral intermediate known for the preparation of numerous amino alcohol derivatives [3]. To the best of our knowledge, the use of this substrate was never demonstrated in radical chemistry.

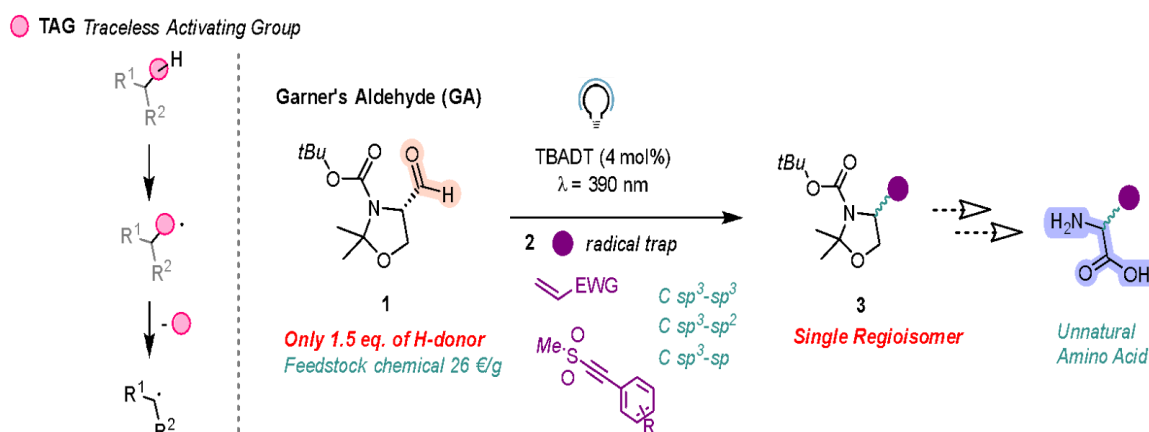

Figure 1

- [1] L. Capaldo, D. Ravelli, and M. Fagnoni, *Chem. Rev.* 122 (2022) 1875-1924  
[2] M. Galeotti, M. Salamone, and M. Bietti, *Chem. Soc. Rev.* 51 (2022) 2171-2223  
[3] M. Passiniemi, and A. M. P. Koskinen, *Beilstein J. Org. Chem.* 9 (2013) 2641-2659

**Photocatalytic depolymerization of lignin using MoO<sub>3</sub>-based catalysts**

Elena Teresa Palombella,<sup>a</sup> Cosimo Annese,<sup>b,c</sup> Lucia D'Accolti,<sup>a,c</sup> Caterina Fusco,<sup>c</sup> and Federico Liuzzi<sup>d</sup>

<sup>a</sup>*Dipartimento di Chimica, Università degli Studi di Bari "Aldo Moro", Via E. Orabona 4, 70125-Bari, Italy*

<sup>b</sup>*Dipartimento di Scienze della Vita, della Salute e delle Professioni Sanitarie, Università degli Studi "Link Campus University", Via del Casale di San Pio V, 4400165 Roma, Italy*

<sup>c</sup>*Consiglio Nazionale delle Ricerche (CNR) – Istituto dei Composti OrganoMetallici (ICCOM), via Orabona 4, 70126 Bari, Italy*

<sup>d</sup>*Agenzia nazionale per le nuove tecnologie, l'energia e lo sviluppo economico sostenibile (ENEA), ENEA C.R. Trisaia S.S. 106 Jonica, 75026, Rotondella, MT, Italy*

*E-mail: elena.palombella@uniba.it*

Lignin, a primary structural component of lignocellulosic biomass, is the most abundant renewable source of aromatics in nature [1]. While cellulose has been widely used in paper and pulp industry, lignin remains a by-product and is often considered a waste and burned to supply energy for the process [2].

However, lignin holds significant potential for producing bio-based products through efficient depolymerization techniques. Various classical depolymerization protocols, including thermochemical, oxidative, photocatalytic, biochemical and electrochemical methods, have been developed, each one producing a variety of end products depending on the specific operating conditions.

Among these methods, photocatalysis is considered environmentally friendly and highly appealing, due to its advantages, such as being clean, effective, energy-saving, and low-cost [3]. These benefits make photocatalysis a highly promising approach for sustainable lignin valorization.

In this study, we explored the potential of molybdenum trioxide (MoO<sub>3</sub>) as a photocatalyst in the lignin depolymerization, using both commercial alkali lignin and samples of lignin obtained from enzymatic hydrolysis of steam-exploded wheat straw. MoO<sub>3</sub> is a n-type semiconductor, which has attracted a lot of attention for its high photocatalytic activity. Additionally, it is environmentally friendly and cost-effective, making it an attractive option for industrial-scale applications.

Results show that lignin is efficiently depolymerized into small aliphatic and aromatic molecules in alkaline aqueous solution under UV–vis irradiation. Furthermore, we found that functional modifications of MoO<sub>3</sub> result in increased catalyst efficiency and reaction yields.

[1] K. Cantrell, K. Ro, D. Mahajan, M. Anjom, and P.G. Hunt, *Industrial and Engineering Chemistry Research* 46 (2007) 8918-8927

[2] M. Balat, and H. Balat, *Applied Energy* 86 (2006) 2273-2282

[3] H. Li, Z. Lei, C. Liu, Z. Zhang, and B. Lu, *Bioresour. Technol.* 175 (2015) 494-501

## Valorization of Apple Pomace: bacterial cellulose-immobilized $\beta$ -Glycosidase allows efficient production of phloretin

Luca Nespoli, Agostina Colacicco, Emma Ribul Moro, Francesco Molinari,

Stefano Farris, Martina Letizia Contente, and Diego Romano

Department of Food, Environmental And Nutritional Sciences, Università degli Studi di Milano "La Statale", Via Mangiagalli 25, 20133, Italy  
E-mail: [luca.nespoli@unimi.it](mailto:luca.nespoli@unimi.it)

Food industries produce around 4 million metric tons every year of apple pomace [1], a mixture of residues and byproducts from apple processing. A high abundance of valuable phenolic compounds is still present in apple residues, though representing a cheap natural source of bioactive molecules for many industrial applications.

Among these compounds, phloretin (PHL) is drawing particular attention for its biological properties. However, due to its small amount present in the biomass with respect to its glycoside, phloridzin (PHZ), the latter is used as starting material of choice [2]. Our group used apple waste to grow *Komagataeibacter xylinus* DSM2325, an acetic acid bacterium, able to produce high quantity of bacterial cellulose (BC).

By simple chemical modifications [3], we turned it into a promising support for enzymatic immobilization of extremophilic  $\beta$ -glycosidase AheGH174. Using imm-AHeGH1 in a biphasic systems (HEPES buffer:TMO 50:50, 20 mg/mL imm-AHeGH1, 2 mg/g<sub>matrix</sub> enzyme loading, 5 g/L phloridzin) complete de-glycosylation is observed after 7 h of reaction.

While the enzyme immobilization onto BC cellulose pellicles allowed for high catalyst stabilization and reuse (>7 cycles), the employment of the unconventional green solvent TMO dramatically facilitated the isolation of the desired product (i.e., 95% of yield), leaving the sugar moieties in the water phase for their potential reutilization.

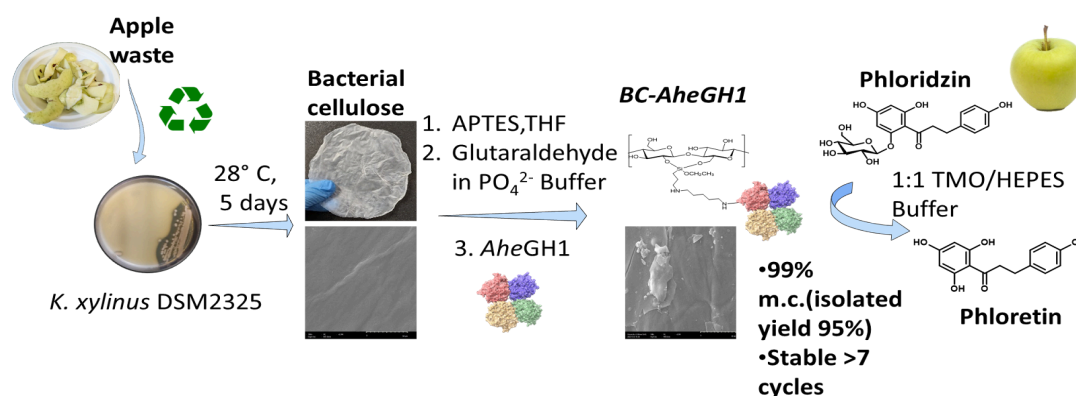

**Figure 1:** Schematic representation for the biocatalytic production of phloretin.

## Tackling neuroinflammation with H<sub>2</sub>S releasing FPR2 agonists

Leonardo Brunetti,<sup>a</sup> Fabio Francavilla,<sup>a</sup> Igor A. Schepetkin,<sup>b</sup> Liliya N. Kirpotina,<sup>b</sup> Ewa Trojan,<sup>c</sup> Mauro Niso,<sup>a</sup> Mark T. Quinn,<sup>b</sup> Agnieszka Basta-Kaim,<sup>c</sup> Marcello Leopoldo,<sup>a</sup> and Enza Lacivita<sup>a</sup>

<sup>a</sup> *Dipartimento di Farmacia-Scienze del Farmaco, Università degli Studi di Bari Aldo Moro, Via Orabona 4, 70126 Bari (BA), Italy*

<sup>b</sup> *Department of Microbiology and Cell Biology, Montana State University, Bozeman, MT 58717, USA*

<sup>c</sup> *Department of Experimental Neuroendocrinology, Maj Institute of Pharmacology PAS, Cracow 12 Smętna Str, PL 31-343 Krakow, Poland*  
E-mail: [leonardo.brunetti@uniba.it](mailto:leonardo.brunetti@uniba.it)

Neuroinflammation is a hallmark of neurodegenerative diseases. It has been linked to tissue damage by oxidative stress, driving neurodegeneration, and its resolution could alter disease progression and outcome [1].

Formyl Peptide Receptor 2 (FPR2) is a G protein-coupled receptor (GPCR), highly expressed by microglial cells and binding several different ligands which elicit either pro-inflammatory or anti-inflammatory effects depending on their structure. This makes it a notable target for the resolution of neuroinflammation [2].

In the past, our group developed the ureidopropanamide class of FPR2 agonists. More recent efforts have led us to try and enhance the anti-inflammatory capabilities of these compounds following different strategy. Herein we present the introduction of H<sub>2</sub>S releasing moieties into the ureidopropanamide scaffold. H<sub>2</sub>S is a gaseous neuromodulator and neuroprotector, active as a calcium influx regulator and as an anti-inflammatory and antioxidant agent [3]. Thus we converted the ureido and amide moieties of our compounds into the corresponding thioureas and thioamides.

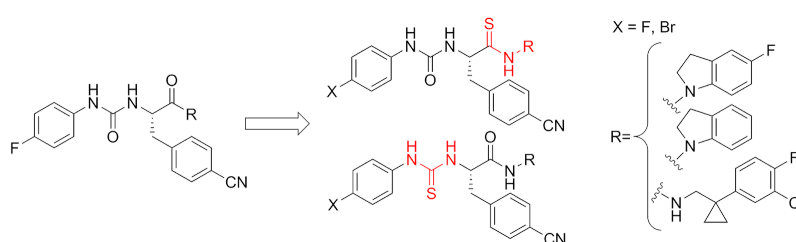

**Figure 1:** scaffolds of ureidopropanamide FPR2 agonists and their thioureido and thioamide counterparts.

We assayed the activity of our compounds as FPR2 agonists, their capacity as H<sub>2</sub>S releasers and their neuroprotective activity in models of neuroinflammation, showing their potential as new anti-inflammatory drugs.

[1] Teleanu, D.M. et al. *Int J Mol Sci* (2022), 23, 5938

[2] Mastromarino, M. et al. *J Med Chem* (2022), 65, 5004–5028

[3] Dilek, N. et al. *Pharmacol Res* (2020), 161, 105119

**Optimization of enzymatic stability of the antimicrobial peptide calcitermin**Silvia Leveraro,<sup>a</sup> Denise Bellotti,<sup>a</sup> and Maurizio Remelli<sup>a</sup>

<sup>a</sup> *Dipartimento di Scienze Chimiche, Farmaceutiche e Agrarie, Università degli Studi di Ferrara, via Luigi Borsari 46, 44121 Ferrara, Italy.  
E-mail: silvia.leveraro@unife.it*

Antibiotic resistance is one of the major threats to global health in the 21<sup>st</sup> century. Antibiotics are powerful life-saving drugs, but over time they are losing their effectiveness due to the emerging growth of antimicrobial resistance (AMR). Although the design of new drugs is necessary to slow-down the spread of AMR, a slow-down is instead registered in the development of new antibiotics, due to a decrease in investments. Among several approaches, the use of antimicrobial peptides (AMPs) is one of the most promising. Also known as host defense peptides, they are a wide group of natural peptides playing a critical role in the innate immune system of various organisms. They are characterized by a broad spectrum of activity and scarce attitude to induce antimicrobial resistance, since they can act through different mechanisms of action. However, they present some drawbacks; above all, they are often metabolically unstable, since they are subject to degradation by both human and pathogenic proteolytic enzymes. In fact, many endo- and exo- peptidases act to transform high molecular weight peptides into shorter oligopeptides, thus making them inactive. This translates in short half-lives and limited bioavailability.

Among several AMPs, we are interested in calcitermin [1], a human 15 amino-acids antimicrobial peptide: VAIALKAAHYHHTHKE. Calcitermin presents an effective metal binding domain encompassing three alternated histidine residues (His 9, His 11 and His 13) in addition to its free terminal amino and carboxyl groups. However, it presents a rather low proteolytic stability with a half-life of 18 min. In the last few years, our research group synthesized and studied many derivatives of calcitermin, aimed at improving its biologic activity through a longer stability towards proteolytic enzymes. We introduced some substitutions such as Ala-to-Ser [2], Ala-to-His or Ala-to-Arg. We also studied terminally protected derivatives [3] and mutants in which some amino acids are substituted with their D-isomers. Some of these modifications have been proven excellent strategies for increasing the resistance to degradation.

[1] D. Bellotti, M. Toniolo, D. Dudek, A. Mikolajczyk, R. Guerrini, A. Matera-Witkiewicz, M. Remelli, M. Rowinska-Zyrek, Dalton Trans. 2019, 48 (36), 13740-13752.

[2] S. Leveraro, K. Garstka, P. Sliwka, T. Janek, M. Rowinska-Zyrek, M. Remelli, D. Bellotti, Dalton Transaction 2024.

[3] M. D'Accolti, D. Bellotti, E. Dzien, C. Leonetti, S. Leveraro, V. Albanese, E. Marzola, R. Guerrini, E. Caselli, M. Rowinska-Zyrek, M. Remelli, Sci Rep 2023, 13, 18228.

*Financial support of the National Recovery and Resilience Plan (NRRP), Mission 4 Component 2 Investment 1.1-NextGenerationEU (PRIN PNRR 2022- 92022EMY52) is gratefully acknowledged.*

## HDAC6 inhibitors based on 2-amino-pyrrolopyrimidine and purine scaffolds: synthesis and biological evaluation for prostate cancer treatment

Federica Borghi, Antonio Laus, Silvia Franchini, Luca Pinzi, Claudia Sorbi, and Giulio Rastelli

Dipartimento di Scienze della Vita, Università degli studi di Modena e Reggio Emilia, Via Giuseppe Campi, 103, Modena, Italy

E-mail: [federica.borghi@unimore.it](mailto:federica.borghi@unimore.it)

Prostate cancer (PCa) is the second most commonly diagnosed tumor in men.

Although current treatments are effective in early-stage disease, they lack efficacy in advanced stage and metastatic castrate-resistant prostate cancer (CRPC). HDAC6 plays a pivotal role in maintaining and modulating androgen receptor expression and is involved in tumor genesis, metastasis and drug resistance. Therefore, the possibility to selectively inhibit HDAC6 represents a promising strategy to treat CRPC.

Recently, we identified potent pyrrolo-pyrimidine/purine HDAC inhibitors with excellent antiproliferative activity and anti-migration properties on PCa [1-2]. To advance this research, we designed two series of 2-aminopyrrolopyrimidine and purine derivatives featuring:

- a hydroxamate or 3-hydroxyisoxazole as Zinc Binding Group (ZBG), required for coordinating the catalytic zinc ion present in the narrow catalytic pocket of HDAC6;
- a cap group, represented by pyrrolopyrimidine or purine, located on the outer surface of the binding pocket and important for driving isoform selectivity;
- a benzyl linker of variable length bearing different decorations, facilitating interaction with surrounding amino acids and linking the two previously described scaffolds (Figure 1).

Two efficient synthetic routes were identified, yielding the desired compounds. *In vitro* testing demonstrated significant inhibition of HDAC6 and marked antiproliferative activity. The results of the *in-silico* design, chemical synthesis, and biological evaluation of the two series of compounds will be presented.

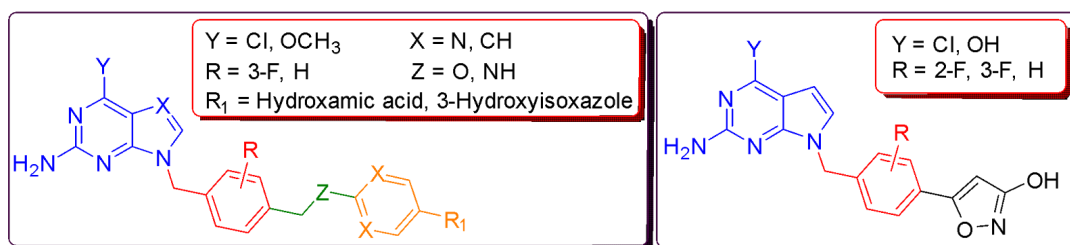

**Figure 1:** General structures of the HDAC6 inhibitors.

[1] P. Linciano, L. Pinzi, S. Belluti, U. Chianese, R. Benedetti, D. Moi, L. Altucci, S. Franchini, C. Imbriano, C. Sorbi, G. Rastelli, *J. Enzyme Inhib. Med. Chem.* 36:1 (2021) 2080-2086.

[2] D. Moi, D. Bonanni, S. Belluti, P. Linciano, A. Citarella, S. Franchini, C. Sorbi, C. Imbriano, L. Pinzi, G. Rastelli, *Eur. J. Med. Chem.* 260 (2023) 1-29.

## Direct and straightforward access to $\alpha$ -chloro and $\alpha$ , $\alpha$ -dichloroacetamidines via homologation of diaryl-carbodiimides and consecutive electrophile trapping

Davide Castiglione, and Vittorio Pace

University of Turin, Department of Chemistry, via P. Giuria 7 – 10125 Turin (Italy)

Email: [davide.castiglione@unito.it](mailto:davide.castiglione@unito.it)

The direct transfer of a reactive nucleophilic  $\text{CH}_2\text{X}$  unit into an existing linkage enables the formal introduction of the moiety with the precisely defined degree of functionalization [1]. Upon the fine tuning of the reaction conditions governing the transformation, the initial homologation event can serve as the manifold for triggering unusual rearrangement sequences leading to complex architectures through a unique synthetic operation [2].

Herein, we report the controlled insertion of a methylene unit into the C-(*sp*) carbodiimidic moiety as heterocumulene electrophilic platforms. By properly selecting the competent lithium carbenoid involved in the protocol, a divergent synthesis of mono- and dihaloacetamidines is obtained. Furthermore, by adding a selected external electrophile (e. g. benzyl bromide) after the initial homologating step, an *N*-alkylation occurs to afford a fully substituted final product in one single synthetic operation.

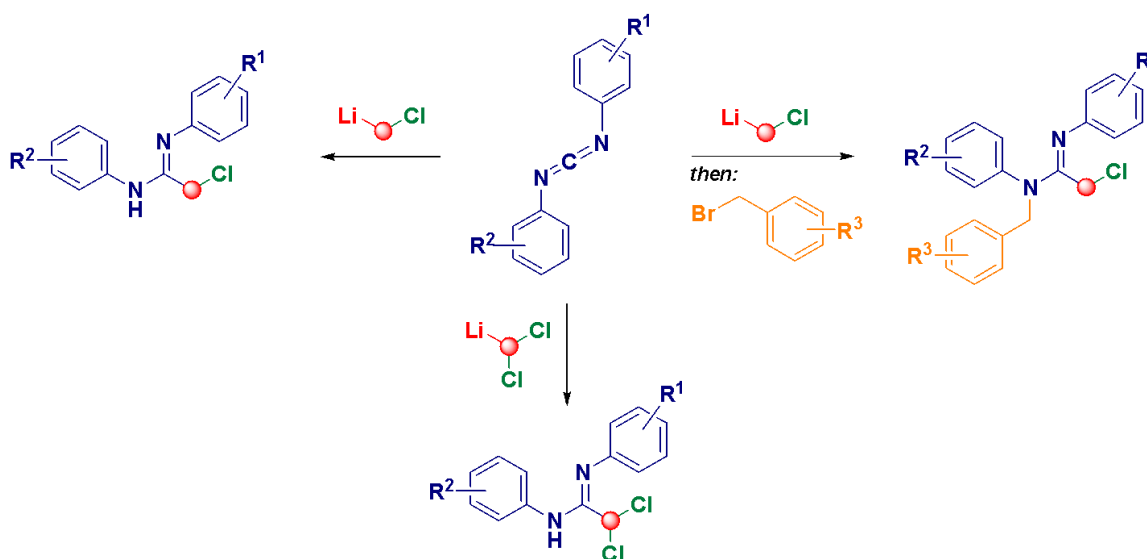

**Figure 1:** Lithium carbenoid mediated divergent synthesis of  $\alpha$ -chloro and  $\alpha$ , $\alpha$ -dichloroacetamidines.

[1] (a) L. Castoldi, S. Monticelli, R. Senatore, L. Ielo and V. Pace *Chem. Commun.* 54, (2018), 6692-6704. (b) R. Senatore, L. Castoldi, L. Ielo, W. Holzer and V. Pace *Org. Lett.* 20, (2018), 2685-2688.

[2] (a) V. Pace, L. Castoldi, E. Mazzeo, M. Rui, T. Langer and W. Holzer, *W. Angew. Chem. Int. Ed.* 56 (2017), 12677-12682. (b) R. Senatore, M. Malik, T. Langer, W. Holzer and V. Pace *Angew. Chem. Int. Ed.* 60 (2021), 24854-24858.

## Divergent behavior of acyl halides towards formal trihalomethyl-homologating agents

Eisuke Comas, Margherita Miele, and Vittorio Pace

Department of Chemistry, University of Turin, Via Giuria 7, 10125, Italy (Turin)

E-mail: [eisukeignacio.comasiwasita@unito.it](mailto:eisukeignacio.comasiwasita@unito.it)

The last years have seen a significant increase in interest in homologation chemistry, which has resulted in several studies and publications examining potential substrate and homologating agent combinations [1]. This work is focused on the reactivity of acyl halides in front of homologating agents, those carboxylic acid derivatives are commonly used as electrophiles in organic chemistry in which the -OH group of the acid is replaced by a halogen atom.

The aim of this work was to investigate the different behaviour of acyl chlorides and acyl fluorides towards formal trihalomethyl-homologating agents. The trihalomethyl carbanion used for the reaction is easily generated after treatment of a carbon tetrahalide with hexamethylphosphorous triamide and is let to react with the chosen acyl halide under Barbier conditions at low temperatures (Figure 1) [2,3].

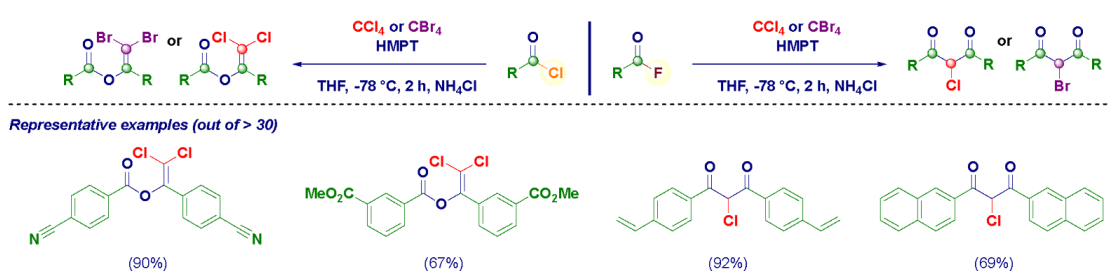

**Figure 1:** Scope of the reaction.

The reaction showed an interesting divergent behaviour giving two different products just by changing the starting acyl halide. In the work some examples for the reactions are reported both with carbon tetrachloride and carbon tetrabromide. The reactions that have been studied represent two new synthetic procedures to access  $\beta$ -dihaloeneol esters and 2-halo-1,3-diones with unprecedented simplicity in just one straightforward reaction step. Moreover, the products obtained from the reactions are valuable substrates presenting both electrophilic and nucleophilic sites in the same molecule thus they can be further transformed and functionalized with ease to obtain even more complex products.

[1] Pace, V. *Homologation Reactions: Reagents, Applications and Mechanisms*. Wiley-VCH: Weinheim, (2023).

[2] R. Rabinowitz and R. Marcus, *J. Am. Chem. Soc.* (1962), 84, 7, 1312–1313.

[3] N. B. Desai, N. McKelvie, and F. Ramirez, *J. Am. Chem. Soc.* (1962), 84, 9, 1745–1747.

## Discovery of highly selective sigma-1 receptor ligands for the treatment of allodynic conditions

G. Cosentino,<sup>a</sup> M. Dichiarà,<sup>a</sup> F. A. Ambrosio,<sup>b</sup> C. G. Leotta,<sup>d</sup> G. Costa,<sup>b,c</sup> F. Procopio,<sup>b</sup> G. Costanzo,<sup>a</sup> A. Raffa,<sup>a</sup> A. Artacho,<sup>e</sup> M. C. Ruiz-Cantero,<sup>e</sup> L. Pasquinucci,<sup>a</sup> A. Marrazzo,<sup>a</sup> G. M. Pitari,<sup>d</sup> E. J. Cobos,<sup>e</sup> S. Alcaro,<sup>b,c</sup> E. Amata<sup>a</sup>

<sup>a</sup> University of Catania, Dipartimento di Scienze del Farmaco e della Salute, Viale A. Doria 6, 95125 Catania, Italy.

<sup>b</sup> Dipartimento di Scienze della Salute, Università "Magna Græcia" di Catanzaro, Campus "S. Venuta", 88100 Catanzaro, Italy.

<sup>c</sup> Net4Science Academic Spin-Off, Università "Magna Græcia" di Catanzaro, Campus "S. Venuta", 88100 Catanzaro, Italy.

<sup>d</sup> Vera Salus Ricerca S.r.l., Via Sigmund Freud 62/B, 96100 Siracusa, Italy.

<sup>e</sup> Departamento de Farmacología e Instituto de Neurociencias, Facultad de Medicina, Universidad de Granada e Instituto de Investigación Biosanitaria de Granada ibs.GRANADA, Avenida de la Investigación, 18016 Granada, Spain.

E-mail: [giuseppe.cosentino@phd.unict.it](mailto:giuseppe.cosentino@phd.unict.it)

Neuropathic pain (NP) occurs due to a direct damage or disease impacting the peripheral or central somatosensory nervous system. The management of NP remains challenging and the sigma-1 receptor (S1R) arises as promising target with S1R antagonists exhibiting significant antyallokinic effects in *in vivo* NP animal models [1].

This study aims to develop new, potent, and selective ligands for S1R that can provide effective *in vivo* analgesia (Figure 1). The binding affinities of these derivatives were evaluated for both S1R and sigma-2 receptor (S2R) using radioligand assays and corroborated by molecular modelling studies [2].

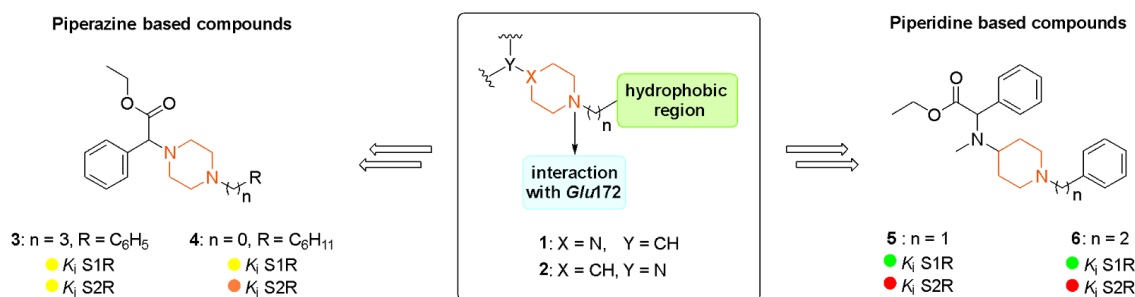

**Figure 1.** Chemical structures and binding affinity of some developed compounds.

The development of these new ligands represents a significant step forward in the quest for more effective NP treatments. Indeed, the potent and selective S1R ligands **5** and **6** have demonstrated excellent safety profile and analgesic effect in *in vivo* mouse model of NP.

[1] M. Dichiarà, F. A. Ambrosio, S. M. Lee, M. C. Ruiz-Cantero, J. Lombino, A. Coricello, G. Costa, D. Shah, G. Costanzo, L. Pasquinucci, K. No Son, G. Cosentino, R. González-Cano, A. Marrazzo, V. K. Aakalu, E. J. Cobos, S. Alcaro, E. Amata. *J. Med. Chem.* (2023), 66(16), 11447-11463.

[2] Dichiarà, M.; Ambrosio, F. A.; Barbaraci, C.; González-Cano, R.; Costa, G.; Parenti, C.; Marrazzo, A.; Pasquinucci, L.; J. Cobos, E.; Alcaro, S.; Amata, E. *ACS Chem. Neurosci.* (2023), 14(10), 1845-1858.

## Seed4Green: unlocking HMF-DES potential for a green transition

Grazia Isa C. Righetti,<sup>a</sup> Maria Enrica Di Pietro,<sup>a</sup> Arianna Rossetti,<sup>a</sup> Andrea Mezzetta,<sup>b</sup> Lorenzo Guazzelli,<sup>b</sup> Giulia Adriana Bracchini,<sup>c</sup> Alessandro Triolo,<sup>c</sup> and Andrea Mele<sup>a</sup>

<sup>a</sup> Department of Chemistry, Materials and Chemical Engineering, Politecnico di Milano, Piazza Leonardo da Vinci 32, 20133 - Milano, Italy

<sup>b</sup> Department of Pharmacy, University of Pisa, Via Bonnano 33, 56126, Pisa, Italy

<sup>c</sup> ISM-CNR, Via Fosso Del Cavaliere 100, 00133, Roma, Italy

E-mail: graziaisacarla.righetti@polimi.it

The development of sustainable and efficient processes for biomass exploitation represents a primary target both in industrial and academic research. In particular, 5-hydroxy methylfurfural (HMF) has gained increasing attention as it is a valuable synthon for many chemicals.[1-3] New and sustainable chemical routes can be achieved by using alternative reaction systems as selected mixtures of Hydrogen Bond Donors and Acceptors (HBDs, HBAs). In this context, HMF interaction with selected type V Deep Eutectic Solvents (DESs) has been assessed by multinuclear NMR, FTIR and Raman spectroscopy. Based on previous HMF-DES systems scouting, HMF reactivity in the most promising DESs has been studied (**Figure 1**).

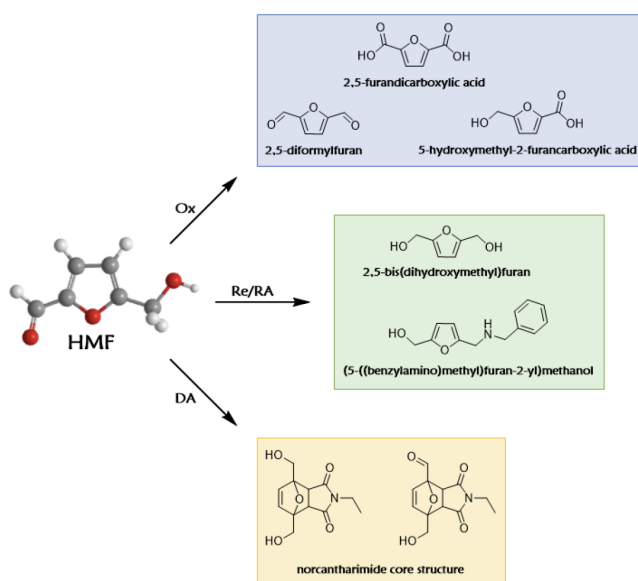

**Figure 1:** Proposed HMF transformation in DES.

Acknowledgement: The SEED4GREEN project has been funded by European Union – Next Generation EU in the framework of the PRIN 2022 (project SEED4GREEN - Code 20223W4RT9).

[1] Nolan M. D., Mezzetta A., Guazzelli L., Scanlan E. M., Green Chemistry, 2022, 24, 1456-1462.

[2] Arnaboldi S., Mezzetta A., Grecchi S., Longhi M., Emanuele E., Rizzo S., Arduini F., Micheli L., Guazzelli L., Mussini P. Electrochimica Acta, 2021, 380, 138-189

[3] Iris K.M. Yu, Daniel C.W. Tsang, Biosourced Technology, 2017, 238, 716-732

**Innovative synthesis of ZIF-8 in glycerol carbonate as a green alternative to DMF: a comparative life cycle assessment**

Alessandra Sessa <sup>a</sup>, Prisco Prete <sup>a</sup>, Daniele Cespi <sup>b</sup>, Eleonora Rossi <sup>b</sup>, Fabrizio Passarini <sup>b</sup>  
and Raffaele Cucciniello <sup>a</sup>

<sup>a</sup> *Department of Chemistry and Biology “Adolfo Zambelli”, Università degli Studi di Salerno, Via Giovanni Paolo II, 132 - 84084 Fisciano (SA), Italy*

<sup>b</sup> *Department of Industrial Chemistry “Toso Montanari”, Alma Mater Studiorum Università di Bologna, Viale del Risorgimento, 4 - 40136, Bologna (BO), Italy*  
E-mail: [alesessa@unisa.it](mailto:alesessa@unisa.it)

The environmental issues we have been facing in the latest years are well-known to all: global warming, pollution and waste accumulation are the undeniable evidence of a wrong management of earth resources and lack of effective regulations. Meanwhile, the worldwide scientific community is increasingly aware of its decisional role and the current trend is to direct industry and institutions towards more sustainable choices: in this context, the Life Cycle Assessment (LCA) methodology, regulated by the International Standardization Organization (ISO) [1], comes to our aid. This tool allows to associate environmental impacts to the whole manufacturing cycle, from the supplying of raw materials to the product end-of-life. In this work an example of “*cradle to gate*” LCA referring to a laboratory-scale process is given. The functional unit is 1g of ZIF-8, a versatile and widely employed material belonging to the ZIF (Zeolitic Imidazolate Framework) class. ZIFs are hybrid materials between MOFs and zeolites, and they have recently gained the attention of the scientific world for their exceptional features, such as crystallinity, porosity, as well as high chemical and thermal stability. ZIF-8 consists of zinc clusters linked to 2-methylimidazole (2-MIm) units, and it is mostly synthesized through the solvothermal method, where  $ZnX_2$  ( $X = CH_3COO^-$ ,  $Cl^-$ ,  $NO_3^-$ ) and 2-MIm are separately dissolved in an appropriate solvent and consequently mixed. The traditional solvent for this reaction is *N,N*-Dimethylformamide (DMF), which provides both high yield and great crystallinity of ZIF-8 [2]. The current route based on DMF employment accounts for the SCENARIO 1 of our LCA. However, DMF is a fossil-based solvent, hazardous for the environment and potentially toxic for humans. Thus, the development of new sustainable synthetic strategies represents an urgent requirement to be satisfied. In this regard, glycerol carbonate (GlyC) has been successfully tested for the first time as a green solvent for the synthesis of ZIF-8 [3], showing comparable performances to DMF in terms of both yield and crystallinity of the products. Reaction mixture recycle has also been evaluated for subsequential reaction cycles, showing the ability to carry out ZIF-8 synthesis after five consecutive reactions. This innovative pathway represents the SCENARIO 2 of our LCA. A comparative LCA between scenario A and scenario B is comprehensively described, highlighting the “hotspots” for each process, from the supplying of the reagents (cradle) to the final product (gate).

[1] ISO (2006a) 14040:2006, ISO (2006b) 14044:2006, Geneva, Switzerland: ISO.

[2] M. Bergaoui, M. Khalfaoui, A. Awadallah-Fa, S. Al-Muhtaseb, *J. Nat Gas Sci Eng* 96 (2021) 104289

[3] M. Itatani, N. Némethy, N. Valletti, G. Schuszter, P. Prete, P. Lo Nostro, R. Cucciniello, F. Rossi, I. Lagzi, *ACS SusChem.Eng.* 11 (2023) 13043–13049

## OR021

### A green Heck reaction protocol towards trisubstituted alkenes, versatile pharmaceutical intermediates

Giacomo Rossino,<sup>a</sup> Giorgio Marrubini,<sup>a</sup> Margherita Brindisi,<sup>b</sup> Marc Granje,<sup>a,c</sup> Pasquale Linciano,<sup>a</sup> Daniela Rossi,<sup>a</sup> and Simona Collina<sup>a</sup>

<sup>a</sup> Department of Drug Sciences, Università degli Studi di Pavia, via Taramelli 12, 27100-Pavia, Italy

<sup>b</sup> Department of Pharmacy, Università di Napoli "Federico II", via Montesano 49, 80131-Napoli, Italy

<sup>c</sup> Faculty of Pharmacy and Food Sciences, Universidad de Barcelona, Av. De Joan XXIII 27-31, 08028-Barcelona, Spain

E-mail: [giacomo.rossino@unipv.it](mailto:giacomo.rossino@unipv.it)

The Heck reaction has been widely employed to build a variety of biologically relevant scaffolds and active pharmaceutical ingredients (APIs) [1]. Typically, the reaction with terminal alkenes gives high yields and selectivity, and many green variants of the original protocol have been developed for such substrates [2]. However, these methodologies may not be applied with the same efficiency to reactions with internal olefins, to provide trisubstituted alkenes, which are also privileged structures and useful intermediates of pharmaceutical interest. To fill this gap, we have implemented a Heck reaction protocol under green conditions to access trisubstituted alkenes. A set of preliminary experiments performed on a model reaction led to selecting a simple and green setup based on a design of experiments (DoE) study. The best experimental conditions (catalyst loading, equivalents of alkene, base and solvent) have been identified. Then, a second set of experiments were performed, bringing the reaction to completion and considering additional factors. The protocol thus defined involves using EtOH as the solvent, microwave (mw) irradiation, and the supported catalyst Pd EnCat@40 (Figure 1). These conditions were tested on different aryl bromides and internal olefines to evaluate the substrate scope. Furthermore, a simple isomerization procedure was developed to convert the isomeric byproducts into the desired conjugated E alkene. The approach herein disclosed was recently published, and represents a green, efficient, and easy-to-use handle towards different trisubstituted alkenes via the Heck reaction [3].



**Figure 1:** Comparison between the old and new protocol for the Heck reaction.

[1] M. Prashad, in *Organometallics in process chemistry* Berlin, Heidelberg: Springer Berlin Heidelberg (2004) 181–203

[2] M. Yousaf, A. F. Zahoor, R. Akhtar, M. Ahmad, and S. Naheed *Mol. Divers.* 24 (2020) 821–839

[3] G. Rossino, G. Marrubini, M. Brindisi, M. Granje, P. Linciano, D. Rossi, and S. Collina, *Front. Chem.* 12 (2024)

## The SPINNERET project: fabrication of electrospun nanocomposites for lithium batteries.

Vanessa Da Fermo, Pantaleone Bruni, Vincenzo Ferrone, Serena Pilato, Antonella Fontana, and Stefania Ferrari.

*Department of Pharmacy, University "G. d'Annunzio" of Chieti-Pescara, via dei Vestini 31,  
I-66100 Chieti, Italy.  
E-mail: vdfermo@gmail.com*

Innovation in the energy storage sector is extremely important for the transition to sustainable technologies, as emphasized by the European Green Deal initiative that is based on three fundamental principles for the clean energy transition: i) the reduction of greenhouse gas emissions, ii) the improvement of quality of life, and iii) the promotion of sustainable development. This study, focuses on the production of composite nanofibers and aligns with this perspective, aiming to advance the manufacturing of electrodes for the battery industry by increasing the Technology Readiness Level (TRL) of the patent "Electrospun  $\text{Cu}_2\text{O}$ /Carbon-based nanocomposite materials as anodes for lithium batteries." [1], based on the SPINNERET [2] project. An in-depth chemical-physical characterization, including electrode preparation, is also conducted to optimize the morphology and performance of the resulting material. The project's goal is to achieve progress on a semi-industrial scale, maintaining the high value of the patent and improving the electrochemical performance of the materials. Research on lithium-ion batteries (LIB) is currently essential to meet the growing demand for energy storage. However, the energy density, cycle stability, and safety of LIBs require further improvements for large-scale applications.  $\text{Cu}_2\text{O}$ /Carbon-based nanocomposites exhibit unique properties that can address the challenges associated with electrodes. This material promises a higher storage capacity due to an increased active surface area and better electrical conductivity, while also reducing the environmental impact of battery production [3]. In conclusion, the SPINNERET project promotes innovation in the research and development of advanced materials for lithium batteries. It focuses on the implementation of electrospinning techniques in the fabrication of technologically relevant materials, thereby facilitating industrial-scale production and improving electrochemical performance to tackle the challenges of the global battery market.

### Reference

- [1] Patent number 102018000010452, Materiali nanocompositi elettrofilati a base  $\text{Cu}_2\text{O}$ /Carbone come anodi per batterie al Litio.
- [2] "UdAProVAL" POC 2022 – PNRR Missione 1 Componente 2 Investimento 6, Sviluppo di un Prototipo elettrofilato a base  $\text{Cu}_2\text{O}$ /carbone come anodo di Nuova generazione per batterie al litio -SPINNERET.
- [3] Electrospun Carbon/ $\text{Cu}_x\text{O}$  Nanocomposite material as Sustainable and High Performance Anode for Lithium-Ion Batteries, Fausto Croce et al., doi: 10.1002/open.201900174

## NaCl-Gly deep eutectic electrolyte for stable and high-voltage electrochemical double layer capacitor

Daniele Motta<sup>a</sup>, Alessandro Damin<sup>a,b</sup>, Giuseppe A. Elia<sup>b,c</sup>, Hamideh Darjazi<sup>c</sup>, Stefano Nejrotti<sup>a</sup>, Claudia Barolo<sup>a,b</sup>, Claudio Gerbaldi<sup>b,c</sup>, Matteo Bonomo<sup>a,b</sup>

<sup>a</sup> Department of Chemistry and NIS Interdepartmental Centre, University of Turin, Via Pietro Giuria 7, Torino, 10125, Italy

<sup>b</sup> National Interuniversity Consortium of Materials Science and Technology (INSTM), Via Giuseppe Giusti 9, Firenze 50121, Italy

<sup>c</sup> GAME Lab, Department of Applied Science and Technology (DISAT), Politecnico di Torino, Torino 10129, Italy

E-mail: [daniele.motta@unito.it](mailto:daniele.motta@unito.it)

The pressing need for alternative energy sources has driven the improvement of electrochemical energy storage systems (EESS), including metal-ion batteries and electrochemical double layer capacitors, to enable the widespread adoption of electric vehicles and intermittent technologies like photovoltaic [1]. However, EESS still rely on electrolytes based on organic carbonates, which are flammable, toxic and not environmentally friendly [2]. To address these issues, Deep Eutectic Solvents (DESs) have been proposed as a novel class of electrolytes, due to their several advantages, i.e. low volatility, low flammability and good thermal and electrochemical stability [3].

The aim of our work is to design truly green electrolytes, specifically metal-polyol DESs, for EESS. Through a combination of thermal analysis and vibrational spectroscopies, we successfully classified the mixture NaCl-Gly 1:10 as DES. Moreover, our findings allowed us to correlate both the molecular structure of the components with the mass transport and electrochemical behaviour of the mixture. Finally, the developed DES electrolyte was successfully tested in an electrochemical double-layer capacitor (EDLC) yielding remarkable results (Figure 1) and demonstrating the potential of these cost-effective and eco-friendly electrolytes.

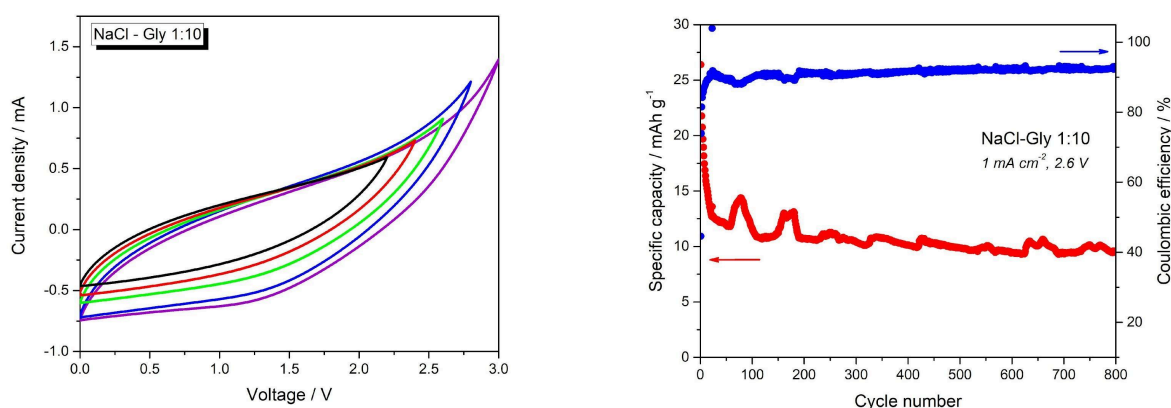

**Figure 1:** Electrochemical test of NaCl-Gly 1:10 in EDLC

[1] A. Dutta, S. Mitra, M. Basak, and T. Banerjee, *Energy Storage* (2023), 5(1) 1–36

[2] J. Zhang, X. Yao, R. K. Misra, Q. Cai, and Y. Zhao, *Journal of Materials Science and Technology* (2020), 44, 237–257

[3] M. E. Di Pietro, and A. Mele, *Journal of Molecular Liquids* (2021), 338, 116597

## Optimizing synthesis and investigating the behavior of Ni-Fe-Mn-base oxide as positive electrode for Sodium ion battery

Valeria Sperati,<sup>a,b</sup> Remo Zaccaria Proietti,<sup>b</sup> Giuseppe Antonio Elia,<sup>a</sup> and Claudio Gerbaldi<sup>a</sup>

<sup>a</sup>Department of Applied Science and Technology, Politecnico di Torino, Turin, 10129, Italy

<sup>b</sup>Istituto Italiano di Tecnologia, Department of Nanostructures, Genova, 16163, Italy

E-mail: [valeria.sperati@polito.it](mailto:valeria.sperati@polito.it)

Sodium-ion batteries (SIBs) are being considered as a viable alternative to lithium-ion batteries (LIBs) due to their similar physical and chemical properties. However, it is crucial to recognize the distinct differences between SIBs and LIBs[1].

The research presented here focuses on iron-nickel-manganese based oxide materials as positive electrodes for SIBs. The advantages of the high working potential of  $\text{Ni}^{2+/3+/4+}$  and the synergistic effect of Fe and Mn, in addition their abundance, make this class of materials environmentally attractive [2]. The focus is on materials with an O3-type structure, which allows for higher sodium content compared to P2-type structures, thus improving battery performance [3]. However, these materials exhibit air instability and undergo multiple phase transitions during charging and discharging, these issues are highlighted and analyzed in this work.

In this project, the co-precipitation synthesis process has been optimized, taking into account various factors that influence it, and looking at it from different perspectives, including electrochemical performance, structural stability, and moisture sensitivity. The study aims to contribute to the advancement of SIB technology by comprehensively analyzing the above aspects.

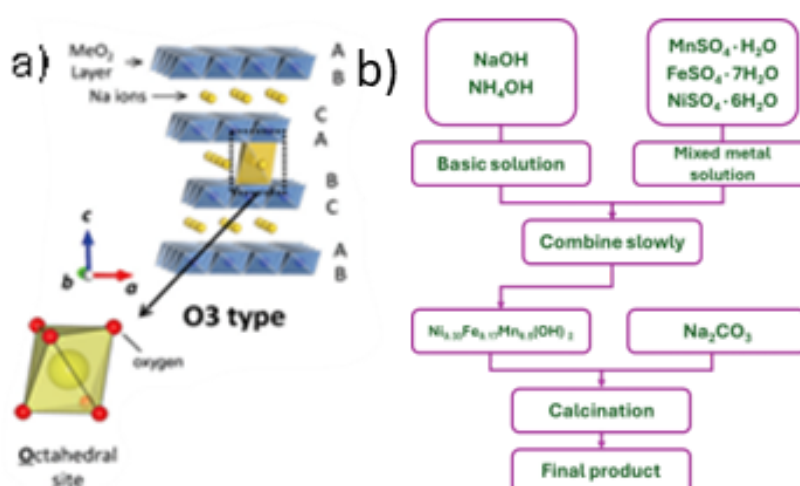

**Figure 1:** a) O3-type structure; b) synthesis protocol.

[1] Y. Cao, et al., *Chemistry–A European Journal* 29 (2023) 12:e202202997

[2] B. Peng, et al., *Advanced Functional Materials* (2024) 2311816

[3] Y. Gupta, et al., *Renewable and Sustainable Energy Reviews*, 192 (2024) 114167

**Development of an eco-friendly bi-layer gel-polymer electrolyte for rechargeable Zinc-Air batteries**Matteo Milanese,<sup>a</sup> Hamideh Darjazi,<sup>a</sup> Giuseppina Meligrana,<sup>a,b</sup>Claudio Gerbaldi,<sup>a,b</sup> Giuseppe A. Elia,<sup>a,b</sup><sup>a</sup> *GAME Lab, Department of Applied Science and Technology, Polytechnic of Torino, Corso Duca degli Abruzzi 24, 10129, Torino, Italy*<sup>b</sup> *National Reference Center for Electrochemical Energy Storage (GISEL) - INSTM, Via G. Giusti 9, Firenze 50121, Italy**E-mail: matteo.milanese@polito.it*

The Green Deal sets ambitious goals for EU climate neutrality by 2050, enabled by a progressive increase of renewable energy share. Achieving these targets requires the development of sustainable and interconnected Electrochemical Energy Storage (EES) systems. Metal-air batteries present several advantages, including using aqueous electrolytes with inorganic salts, cheap and abundant active materials (e.g., zinc), high gravimetric energy density and long-term stability. In such a scenario, the main goal of the HORIZON EUROPE project “HIPERZAB” is to develop an Electrically Rechargeable Zn-Air Battery (ERZAB) ideal for mid-term storage to be coupled with renewable power sources and electrolyzers. HIPERZAB will achieve a paradigm shift with respect to the battery performance, lifetime, safety, sustainability, and costs of liquid electrolyte-based Zn-Air Batteries (ZABs) through the investigation of three innovative components: (i) a 3D porous Zn/biopolymer composite anode, (ii) an eco-friendly bilayer gel biopolymer electrolyte, and (iii) a CRM-free structured cathode. The ultimate goal of the project is to integrate these components in a single device, proposing a radically new gel-electrode-assembly (GEA) battery design with a channelled current collector to enable water/air management control during cycling.

More specifically, we are working on the development of the acidic side of an aqueous Gel Polymer Electrolyte (GPE) that, coupled with the alkaline one [1], will increase the battery operating potential from 1.65 V to 2.55 V and, hence, the overall device energy density from 1353 to 2091 Wh/kg. The electrolyte preparation is based on the use of natural bio-polymers [2][3] and low-cost sustainable chemicals with also the exploration of the use of redox mediators to modulate the kinetics of OER and ORR processes. Particular attention is also paid to the regulation of Zn ion conduction/transport across the interfaces by adjusting the amount of water and the polymer crosslinking density coupled with mechanistic understanding.

**Acknowledgment**

The HIPERZAB project (<https://hiperzab.eu/en>) has received funding from the European Union’s EIC research and innovation programme under grant agreement No 101115421.

[1] García-Gaitán, E. et al., *Chemical Engineering Journal*, 472 (2023) 144870

[2] Sun, P.; et al., *Electrochimica Acta* 429 (2022) 140985.

[3] Tang, Y. Et al., *Energy Storage Materials* 27 (2020) 109-116

## Unveiling key interactions at TiO<sub>2</sub>-anatase/PEO interfaces: a metadynamics study

Arianna Massaro<sup>a,b</sup>, Francesca Fasulo,<sup>b,c</sup> Ana Belen Muñoz-García<sup>b,c</sup> and Michele Pavone<sup>a,b</sup>

<sup>a</sup> Department of Chemical Science, University of Naples Federico II, Compl. Univ. Monte Sant'Angelo, Via Cintia 21, 80126-Naples, Italy

<sup>b</sup> Consorzio Interuniversitario Nazionale per la Scienza e Tecnologia dei Materiali (INSTM), via G. Giusti 9, 50121-Florence, Italy

<sup>c</sup> Department of Physics "E. Pancini", University of Naples Federico II, Compl. Univ. Monte Sant'Angelo, Via Cintia 21, 80126-Naples, Italy  
E-mail: [arianna.massaro@unina.it](mailto:arianna.massaro@unina.it)

Describing heterogeneous electrochemical interfaces rather than single component materials is rapidly emerging as a major challenge in advanced materials design. Considering computational modelling, the demanding task concerns the development of non-standard theoretical approaches for reliably describing complex systems with different chemical nature or intricate processes on different length/time scales [1]. In this context, we focus on a metadynamics study of TiO<sub>2</sub> anatase/poly(ethylene oxide) (PEO) interfaces [2], a case-study system with technological interest in many fields, from biomedicine to energy [3]. By selecting the torsion angle of the polymer chain and the number of Ti-O distances below the equilibrium value (*i.e.*, 2.6Å) as collective variables, we could explore the conformational space and coordination modes adopted by PEO when interacting with the (101) facet. The collected 1 ns-trajectories at 300K computed at DFTB-D3BJ level of theory show that PEO will mostly assume conformations in the range of  $\omega \sim 40^\circ - 120^\circ$  and establish two-/three-fold coordination with the anatase surface. These findings set solid scientific foundations towards future investigations on any interfaces of interest for next-generation energy storage devices.

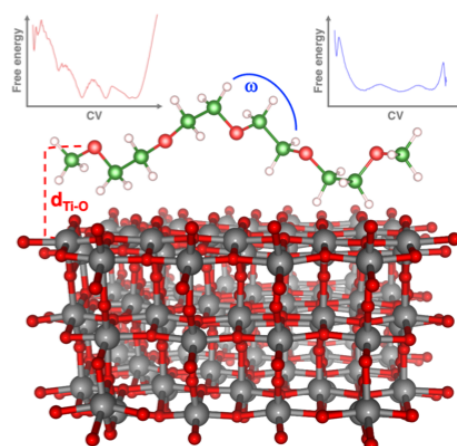

**Figure 1:** Configurational and conformational structuring at (101)-TiO<sub>2</sub>/PEO interfaces.

[1] D. Atkins, *et al.*, *Adv. Energy Mater.*, 12 (2022) 2102687

[2] A. Barducci, M. Bonomi, and M. Parrinello, *WIREs Comput. Mol. Sci.*, 1 (2011) 826

[3] D. Selli, and C. Di Valentin, *J. Phys. Chem. C*, 120 (2016), 29190

**Evaluation of environmental impacts from photovoltaic and optoelectronic devices during non-routine events**

Silvia Orecchio,<sup>a</sup> Davide Ricci,<sup>b</sup> Vittorio Ferrara,<sup>a</sup> Giuseppe Arrabito,<sup>a</sup> Salvatore Barreca,<sup>c</sup> Diana Amorello,<sup>b</sup> Ivana Pibiri,<sup>b</sup> Santino Orecchio,<sup>b</sup> Tiziana Fiore,<sup>a</sup> Michelangelo Scopelliti,<sup>a</sup> and Bruno Pignataro,<sup>a</sup>

<sup>a</sup> Department of Physics and Chemistry, University of Palermo, V.le d. Scienze Ed. 17, 90128 Palermo, Italy

<sup>b</sup> Department of Science and Technology Biological, Chemical and Pharmaceutical, University of Palermo, V.le d. Scienze, 90128, Palermo, Italy

<sup>c</sup> Department of Chemical Sciences, University of Catania, V.le A. Doria 6, 95125 Catania, Italy  
E-mail: [silvia.orecchio@unipa.it](mailto:silvia.orecchio@unipa.it)

To date, most of the world's electricity is produced from fossil fuels, which are non-renewable and emit significant greenhouse gases. Fossil fuel reserves are limited, prompting interest in nuclear energy and renewables (hydroelectric, biomass, geothermal). Among these, solar energy stands out as eco-sustainable. Solar cells pose little risk to human health or the environment, as their semiconductor layers are protected by other materials (e.g., glass). However, issues can arise from broken modules that may leach materials during extreme weather or due to human factors.

Organic-inorganic hybrid perovskite solar cells are among the most studied, achieving power conversion efficiencies up to 26.1%. They are described by the formula  $ABX_3$ , where X represents a monovalent halide anion, A is an organic cation, and B is a divalent metal cation. These metals can be released if exposed to aggressive environments (acid rain, high T). The replacement of inorganic semiconductors with organic materials allows reducing the production costs, enabling solution-processed flexible devices. Here, perfluoroalkylated polyaromatic hydrocarbons (PAHs) have garnered great interest, given their solution processability and high electron mobility. Among them, pyrene derivatives are among the most studied, given their versatile properties.

This study aims at evaluating the environmental impacts of photovoltaic and optoelectronic devices following the events described above or due to abandonment in the field. To this aim, mimicking devices based on perovskite and pyrene functionalized systems have been prepared and tested for their potential environmental impact. This evaluation includes leaching tests to identify environmentally and toxicologically relevant analytes leached from the devices [1]. The detection of  $Pb^{2+}$  and PAH derivatives in solutions obtained from leached materials was carried out using the normalized procedure DIN EN 12457-4:2003-01 and anodic stripping voltammetry, following procedures established and optimized in previous research [2]. This study can represent a first step towards the quantification of the environmental impact of high-performance solar cells.

Financial support from MUR is acknowledged under PRIN 2022 PNRR project “2022WZK874 - IntegRated apprOach to real eco sustainaBIE gReen TotAl index” PRJ-1431, CUP: B53D23025320001 and “Network 4 Energy Sustainable Transition – NEST”, Spoke 1, PE0000021, CUP B73C22001280006, funded under the National Recovery and Resilience Plan (NRRP), Mission 4.

[1] S. Parikhit, and A.Wade, IEEE J-PV 5 (2015) 1-5

[2] D. Amorello, S. Orecchio, S. Barreca, S. Orecchio, *Chemistry Select* 8 (2023) 1-13

## A click inverse electron-demand Diels-Alder reaction for pinpointing carbon-carbon double bonds in untargeted lipidomics

Andrea Cerrato,<sup>a,b</sup> Aldo Laganà,<sup>a,b</sup> Enrico Taglioni,<sup>a,b</sup> Anna Laura Capriotti<sup>a,b</sup>

<sup>a</sup> Dipartimento di Chimica, Sapienza Università di Roma, Piazzale Aldo Moro 5, 00185, Roma, Italia;

<sup>b</sup> Istituto Nazionale di Biostrutture e Biosistemi (INBB), Via dei Carpegna 19, 00165, Roma, Italia

E-mail: [andrea.cerrato@uniroma1.it](mailto:andrea.cerrato@uniroma1.it)

In the latest years, lipidomics has become a prominent tool in clinical chemistry due to the proven connections between lipid dysregulations and the insurgence of pathologies. Despite being the foremost technique for lipidomics, high-resolution mass spectrometry (HRMS) is not sufficient for elucidating the lipid structures, especially when it comes to the regiochemistry of carbon-carbon double bonds, which play a major role in determining the properties of cell membranes [1]. Over the years, several approaches have been proposed in combination with HRMS for elucidating the regiochemistry of double bonds, including unconventional fragmentation techniques and derivatization prior to MS analysis<sup>1</sup>. Among the latter, photochemical reactions, e.g., the Paternò–Büchi reaction, have shown great potential for their versatility, but have the unavoidable drawback of generating several oxidation by-products and splitting the MS signal due to the inherent asymmetry of the reaction that generates multiple derivatives. Among other possible approaches for derivatizing electron-rich double bonds, the emerging inverse electron-demand Diels–Alder (IEDDA) reaction with tetrazines stands out thanks to its unmatched kinetics and so far has found several applications in basic biology, protein imaging, and therapeutics.

In the present study, we present the first proof of concept of a catalyst-free click IEDDA reaction to pinpoint carbon-carbon double bonds in free and conjugated fatty acids in untargeted MS-based lipidomics. To assess the applicability of the IEDDA reaction, fatty acid and phospholipid regioisomers were analyzed alone and in combination to evaluate (i) the obtention of diagnostic product ions following MS/MS fragmentation, (ii) the optimum reaction conditions to maximize the reaction yields, and (iii) the possibility of performing relative quantitation of lipid regioisomers. The preliminary data showed that the reaction not only confirmed its kinetics even with the scarcely activated alkene groups on fatty acyl chains but also minimized the splitting of the MS signal thanks to the symmetric nature of tetrazine reagents. Finally, the optimized IEDDA protocol was employed in an untargeted lipidomics study on plasma samples of patients suffering from prostate cancer and benign prostatic conditions to confirm the applicability of the proposed reaction with complex matrices of clinical interest.

[1] J. R. Bonney, B. M. Prentice, *Analytical Chemistry*, 93 (2021), 6311-6322A.

## TEMPO derivatives-grafted nanogels for antioxidant perspectives

Sara Crosta,<sup>a</sup> Arianna Rossetti,<sup>a,b</sup> and Alessandro Sacchetti<sup>a,b</sup>

<sup>a</sup> Department of Chemistry, Materials and Chemical Engineering “Giulio Natta”, Politecnico di Milano, Via Mancinelli 7, 20131 Milan, Italy

<sup>b</sup> National Interuniversity Consortium of Materials Science and Technology, Florence, Italy  
E-mail: [sara.crosta@polimi.it](mailto:sara.crosta@polimi.it)

Ferroptosis is a recently recognized form of iron-dependent, non-apoptotic programmed cell death implicated in the pathophysiological processes of many diseases, particularly neurodegenerative disorders [1]. Recent studies have identified high levels of lipid peroxidation (LPO), the oxidative degradation of cell membrane lipids *via* free radicals' chain reaction, as the main trigger of ferroptosis [2]. Therefore, to prevent damage to the neurons' phospholipid membrane, an emerging strategy involves the design and development of unconventional antioxidant systems capable of trapping these free radicals. To accomplish that, in the past decade, particular attention has been directed toward the stable nitroxyl radical 2,2,6,6-tetramethylpiperidin-1-oxyl (TEMPO). TEMPO has excellent antioxidant properties, providing anti-inflammatory and cytoprotective effects, which could effectively counteract ferroptosis in neurodegenerative conditions [3]. This project aims to modify TEMPO to form suitably substituted derivatives also with variable lipophilicity to facilitate their localization in phospholipid membranes. To maximize their uptake, these derivatives were loaded and chemically bonded, with varying degrees of grafting, to polyethylene glycol-polyethylene imine (PEG-PEI) nanogels that can be exploited as nanovectors for the selective and controlled release of TEMPO derivatives within neurons (Figure 1).

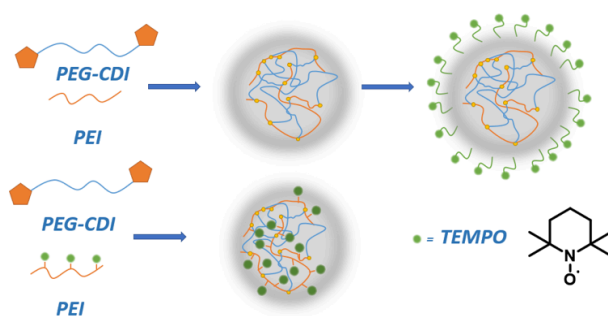

**Figure 1:** TEMPO-modified nanogels

Given their reported good performance, the synthesized materials show particular promise for antioxidant activity, paving the way for a potential application in the biomedical field in the treatment of neurodegenerative conditions.

Funded by the European Union - NextGenerationEU under the National Recovery and Resilience Plan (NRRP) - Mission 4 Education and research - Component 2 From research to business - Investment 1.1 Notice Prin 2022 - DD N. 104 del 2/2/2022, from title “Superoxide responsive redox-active systems and nano smart materials to target ferroptosis – FEROX”, proposal code 20227XZKBY - CUP J53D23008550006

- [1] X. Jiang, B. R. Stockwell, and M. Conrad, *Nature Rev. Mol. Cell. Biol.* 22 (2021) 266-282  
 [2] D. Tang, and G. Kroemer, *Curr. Biol.* 30 (2020), R1292-R1297  
 [3] C. Prescott, and S. E. Bottle. *Cell Biochem. Biophys.* 75 (2017) 227-240

## Olive and grapeseed oils aromatization: influence on quality, stability and sensorial characteristics

Samanta Corsetti,<sup>a</sup> Laura Alessandrini,<sup>a</sup> Monia Floridi,<sup>b</sup> Alberto Casale,<sup>b</sup> and Gianni Sagratini<sup>a</sup>

<sup>a</sup> School of Pharmacy, Chemistry Interdisciplinary Project (ChIP), University of Camerino, Via Madonna delle Carceri, 62032, Camerino, Italy

<sup>b</sup> New Flavours srl, Via Dell'Artigianato 7, 06010, Monte Santa Tiberina, Italy  
E-mail:samanta.corsetti@unicam.it

Nowadays, the global production and use of oilseeds and their processing products are growing dynamically, reaching almost the 99% of the total vegetable oils in the last year. However, among them, grapeseed oil is still not widely used and known, mostly in mediterranean countries where the consumption of olive oil is predominant. Anyway, grapeseed oil is sometimes more affordable than olive oil, whose price increased in the last year. Besides, nowadays in Europe about 3 million tons of grape seeds are discarded in wine production processes. On this line, grapeseed oil can be a valid and sustainable way to reuse them. In fact, grapeseed oil and olive oil provide a similar set of nutrients. The main difference is represented by the higher amount of polyunsaturated fatty acids in grapeseed oil compared to monounsaturated ones that are predominant in olive oil. Moreover, the former was reported to be richer in vitamin E, a powerful antioxidant preventing the onset of certain chronic diseases [1].

Thus, the aim of the present work is to evaluate the impact of aromatization of commercial olive oils and grapeseed oils in terms of added bioactive substances content, volatile compounds, stability, oxidation levels, acidity and sensorial characteristics, comparing them with the unflavored oils. Also the aromatizing matrices were selected as industrial by-products, having lower or no-commercial values due to their size, weight or aspect. The aromatization process was performed through Ultrasound Assisted extraction (UAE) with different vegetal matrices, i.e. pre-dried and grinded Calabrian chili pepper, Sorrento lemon peels (flavedo) and Genovese basil leaves. Indeed, UAE was proven to be the most effective and sustainable technique to extract important bioactive compounds from those vegetal matrices in oils [2]. Oils analyses were performed using chromatographic techniques (HPLC-DAD, HPLC-MS/MS and SPME-GC-MS). Oxidation compounds were determined spectrophotometrically or through titrations, according to the protocols of the European Commission. Sensorial differences of the perceived intensity of aromatization between flavoured olive oils and aromatized grapeseed oils were explored through a panel of consumers.

The main interesting results were the levels of total polyphenols and antioxidant activity that doubled in flavoured oils, compared to the unflavoured ones, while the peroxide value didn't statistically increase in oils aromatized with chili pepper after UAE.

[1] J. Garavaglia, M. M. Markoski, A. Oliveira, and A. Marcadenti, *Nutr. Metab. Insights* 9 (2016)

[2] V. P. Soares, M.B. Fagundes, D.R. Guerra, Y.S.V. Leães, C.S. Speroni, S.S. Robalo, T. Emanuelli, A.J. Cichoski, R. Wagner, J.S. Barin, D.A Bertuol, and C.A. Ballus, *Food Res. Int.* 135 (2020) 109305

## Monitoring of seven pesticide residues by LC-MS/MS in extra virgin olive oil samples and risk assessment for consumers

Marica Erminia Schiano,<sup>a</sup> Federica Sodano,<sup>a</sup> Chiara Cassiano,<sup>a</sup> Elisa Magli,<sup>b</sup> Serenella Seccia,<sup>a</sup> Maria Grazia Rimoli,<sup>a</sup> and Stefania Albrizio<sup>a</sup>

<sup>a</sup> Department of Pharmacy, University of Naples Federico II, via Domenico Montesano 49, 80131-Naples, Italy

<sup>b</sup> Department of Health, University of Naples Federico II, via Pasini 5, 80131-Naples, Italy  
E-mail: [maricaerminia.schiano@unina.it](mailto:maricaerminia.schiano@unina.it)

Italy is one of the main producers and exporters of extra virgin olive oil, with olive trees being one of the primary crops in the Mediterranean regions. However, systematic use of pesticides in olive cultivation aims to safeguard the economic potential of their fruits [1]. In this study, sketched in Figure 1, residue levels of seven pesticides were analyzed in thirty-five samples of Italian-produced Extra Virgin Olive Oil to assess the health risk associated with consuming oils contaminated with these pesticides. An *in-house* analytical procedure was developed and validated, consisting of a specific dispersive solid-phase extraction using the QuEChERS technique and a qualitative-quantitative analysis using liquid chromatography coupled with tandem mass spectrometry [2]. Thirty-four percent of the samples were contaminated with pesticide residues; in the concentration range of 0.53–0.56 ng/mL for imazalil, 1.11–1.56 ng/mL for acetamiprid-*N*-desmethyl, 1.28–1.46 ng/mL for clothianidin, 0.94–1.49 ng/mL for thiacloprid, 1.08–4.64 ng/mL for dinotefuran, 0.42–1.47 ng/mL for thiamethoxam, 0.42–6.14 ng/mL for imidacloprid. Risk assessment was evaluated using the hazard quotient, hazard index, and Pesticide Residue Intake Model by EFSA [3]. All hazard indices confirmed that the concentrations of pesticides detected in the oil samples did not represent a short or long-term risk for consumers' health.

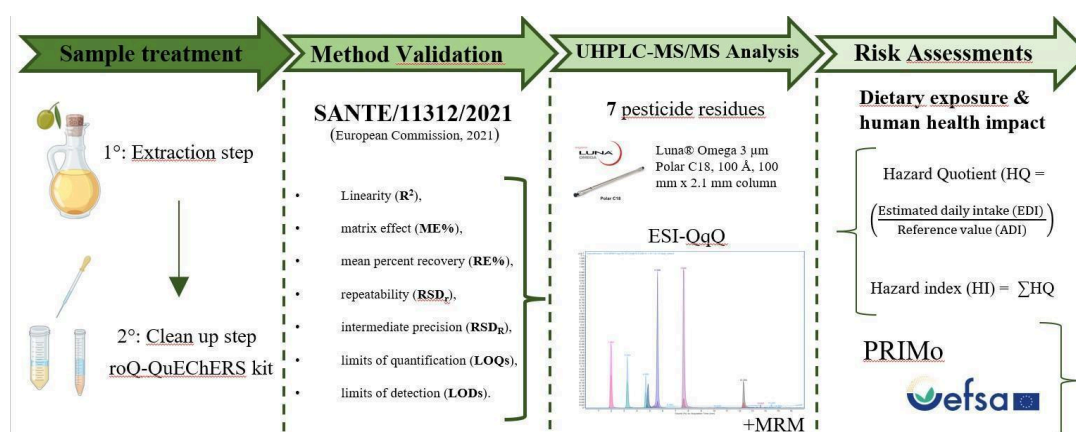

**Figure 1:** Graphical representation of the main contents of this study.

[1] C. Anagnostopoulos, G.E. Miliadis, *Talanta*. 112 (2013) 1–10.

[2] European Commission (2021) No. SANTE 11312/2021.

[3] A. Brancato, D. Brocca, L. Ferreira, L. Greco, S. Jarrar, R. Leuschner, P. Medina, I. Miron, *EFSA Journal*, 16 (2018) 5147

## Dissecting kinetic and thermodynamic aspects of the binding mechanism of melatonergic ligands

Gian Marco Elisi,<sup>a</sup> Annalida Bedini,<sup>b</sup> Michele Retini,<sup>b</sup> Michele Mari,<sup>b</sup> Laura Scalvini,<sup>a</sup> Alessio Lodola,<sup>a</sup> Katia Varani,<sup>c</sup> Fabrizio Vincenzi,<sup>c</sup> Gilberto Spadoni,<sup>b</sup> Marco Mor,<sup>a</sup> Silvia Rivara<sup>a</sup>

<sup>a</sup> Dipartimento di Scienze degli Alimenti e del Farmaco, Università degli Studi di Parma, Parco Area delle Scienze 27/A, Parma I-43124, Italy

<sup>b</sup> Dipartimento di Scienze Biomolecolari, Università degli Studi di Urbino “Carlo Bo”, Piazza Rinascimento 6, Urbino I-61029, Italy

<sup>c</sup> Dipartimento di Medicina Traslazionale, Università degli Studi di Ferrara, Via Luigi Borsari 46, Ferrara I-44121, Italy.

E-mail: [gianmarco.elisi@uniurb.it](mailto:gianmarco.elisi@uniurb.it)

The neurohormone melatonin acts upon binding to the MT<sub>1</sub> and MT<sub>2</sub> receptors, which are G-protein coupled receptors implicated in a variety of activities, including the entrainment of circadian rhythms and neuroprotection. In competition binding experiments for melatonergic ligands, the commonly adopted labeled ligand 2-[<sup>125</sup>I]iodomelatonin exhibits slow dissociation with shorter and longer half-lives at the MT<sub>1</sub> and MT<sub>2</sub> receptor subtypes, respectively. Such slow-binding kinetics may affect affinity constant measurements and structure–activity relationships (SAR), as the dissociation constants values provided in 2-hour experiments could depend on either binding interactions or dissociation pathways. To address these issues, kinetic binding parameters of 2-[<sup>125</sup>I]iodomelatonin were measured, showing that more than 20 hours are required to reach equilibrium at the MT<sub>2</sub> receptor [1]. Indeed, molecular dynamics simulations, evidencing the viability of a lipophilic binding route, showed that the slow dissociation and higher free-energy barrier required to dissociate the ligand from the MT<sub>2</sub> receptor may be due to the restricted mobility of a gatekeeper tyrosine along a lipophilic path, whereas at the MT<sub>1</sub> receptor such residue might help in promoting the formation of a recognition site at the interface with the membrane [1,2]. However, despite the long time needed to reach equilibrium, dissociation constants for various ligands were not significantly altered by the length of the incubation time, indicating that SAR data from shorter incubation times reflect or approximate the equilibrium binding interactions. Therefore, evaluating the dynamic equilibrium of ligands at the orthosteric site elucidates aspects, such as subtype selectivity [3], that, while still not trivial to static models, do not necessitate consideration of the whole unbinding process. In this study, for example, enantiomers of UCM1014 were stereoselectively prepared and their activity rationalized through metadynamics simulations considering just the bound state [1].

[1] A. Bedini, G. M. Elisi, F. Fanini, M. Retini, L. Scalvini, S. Pasquini, C. Contri, K. Varani, G. Spadoni, M. Mor, F. Vincenzi, S. Rivara. *J. Pineal Res.* 76 (2024) 12941.

[2] G.M. Elisi, L. Scalvini, A. Lodola, M. Mor and S. Rivara, *J. Chem. Inf. Model.* 62 (2022) 210-222.

[3] M. Mari, G. M. Elisi, A. Bedini, S. Lucarini, M. Retini, V. Lucini, F. Scaglione, F. Vincenzi, K. Varani, R. Castelli, M. Mor, S. Rivara and G. Spadoni, *Eur. J. Med. Chem.* 243 (2022) 114762.

## Optimized imidazole-thieno[3,2-c]quinolines: promising antiproliferative compounds for thyroid and NCI60 cancer cells

Gabriele La Monica,<sup>a</sup> Alessia Bono,<sup>a</sup> Federica Alamia,<sup>a</sup> Antonino Lauria,<sup>a</sup> Giuseppe Pizzolanti,<sup>b,c</sup> Giuseppe Siragusa,<sup>c</sup> Concetta Baiamonte,<sup>b</sup> and Annamaria Martorana<sup>a</sup>

<sup>a</sup> Dipartimento “STEBICEF” – Università degli Studi di Palermo, Viale delle Scienze – Ed. 17, 90128-Palermo, Italy.

<sup>b</sup> ATeN Center—Advanced Technologies Network Center, 90127-Palermo, Italy.

<sup>c</sup> Dipartimento “PROMISE”, Azienda Ospedaliera Universitaria Policlinico Paolo Giaccone, 90127-Palermo, Italy.

E-mail: [gabriele.lamonica01@you.unipa.it](mailto:gabriele.lamonica01@you.unipa.it)

Medullary thyroid cancer (MTC), a highly aggressive endocrine malignancy, is characterized by mutations in key oncogenic targets, including RET kinase. Targeting these signaling pathways is a promising approach to improve MTC therapeutic treatment [1]. Lead optimization studies [2], allowed us to develop a new series of thieno[3,2-c]quinolines **1a-l** (Figure 1) with a hydrophilic imidazole moiety, to enhance both pharmacokinetic and pharmacodynamic profiles.

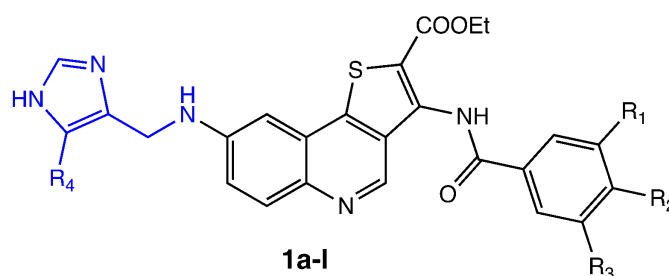

**Figure 1:** general structure of antiproliferative thieno[3,2-c]quinoline compounds **1a-l**.

The thienoquinolines were successfully prepared by appropriate multistep procedures and characterized spectroscopically. *In vitro* evaluation of derivatives **1a-l** showed remarkable IC<sub>50</sub> values in the 0.5-5.7 μM range against two MTC cell lines, TT(RET<sup>M918T</sup>) and MZ-CRC-1(RET<sup>C634R</sup>), which are known to be responsive to only a limited spectrum of anticancer drugs. Additionally, all the synthesized compounds were screened by the National Cancer Institute (NCI) under the Developmental Therapeutic Program (DTP) and tested on sixty human cell lines belonging to nine different cancer panels. Six derivatives were selected for further 5-dose assays and exhibited sub-micromolar IC<sub>50</sub> values, particularly against leukemia and NSCLC panels (ranging from 0.1 to 4.9 μM). Ongoing *in vitro* biological testing will better clarify the mechanism of action (effects on cell cycle regulation, apoptotic pathways, and inhibition of key targets).

**Acknowledgments:** This work was supported by SiciliAn MicronanOTech Research And Innovation Center “SAMOTHRACE” (MUR, PNRR-M4C2, ECS\_00000022), spoke 3 -Università degli Studi di Palermo “S2-COMMs - Micro and Nanotechnologies for Smart & Sustainable Communities”.

[1] M.L. Gild, R.J. Clifton-Bligh, L.J. Wirth and B.G. Robinson, *Endocr Rev* (2023) 44, 934-946.

[2] G. La Monica, G. Pizzolanti, C. Baiamonte, A. Bono, F. Alamia, F. Mingoia, A. Lauria, A. Martorana, *ACS Omega* (2023), 8, 34640-34649.

## OR034

### Selective HDAC6 inhibitors for the fight of metastatic castrate-resistant prostatic cancer



Davide Moi,<sup>a</sup> Andrea Citarella<sup>b</sup> and Giulio Rastelli<sup>c</sup>

<sup>a</sup> Department of Life and Environmental Sciences, University of Cagliari, University Campus, S.P. 8 CA, Monserrato, 09042, Italy

<sup>b</sup> Department of Chemistry, University of Milan, Via Golgi 19, Milano, 20133, Italy

<sup>c</sup> Department of Life Sciences, University of Modena and Reggio Emilia, Via Giuseppe Campi 103, Modena, 41125, Italy

E-mail: [davide.moi@unica.it](mailto:davide.moi@unica.it)

Recent statistics show that prostate cancer (PC) is the most common type of cancer in men, accounting for 27% of all cancer cases and the second-highest death rate at 11%. Unfortunately, the disease often progresses into a castration-resistant form (CRPC) which has a significantly poorer prognosis [1]. Aberrant activation of the androgen receptor (AR) pathway, the most important mechanism fuelling PCA progression, is mainly modulated by Histone Deacetylase 6, (HDAC6) through the modulation of Hsp90 acetylation levels [2]. For this reason the development of HDAC6 inhibitors represents an appealing approach for advanced PC treatment. In our work we designed and synthesized three different classes of selective HDAC6 inhibitors, evaluated for their activity on recombinant HDAC6 enzyme, using HDAC1 as a off-target isoform. The best compounds have been tested *in vitro* against LNCaP cell lines, showing antiproliferative activity at low micromolar levels. We overall found a compound endowed with a combination of favourable drug-like properties, excellent anti-proliferative activity and marked anti-migration properties on PCA cells, thus representing a valuable lead candidate for further *in vivo* evaluation [3].

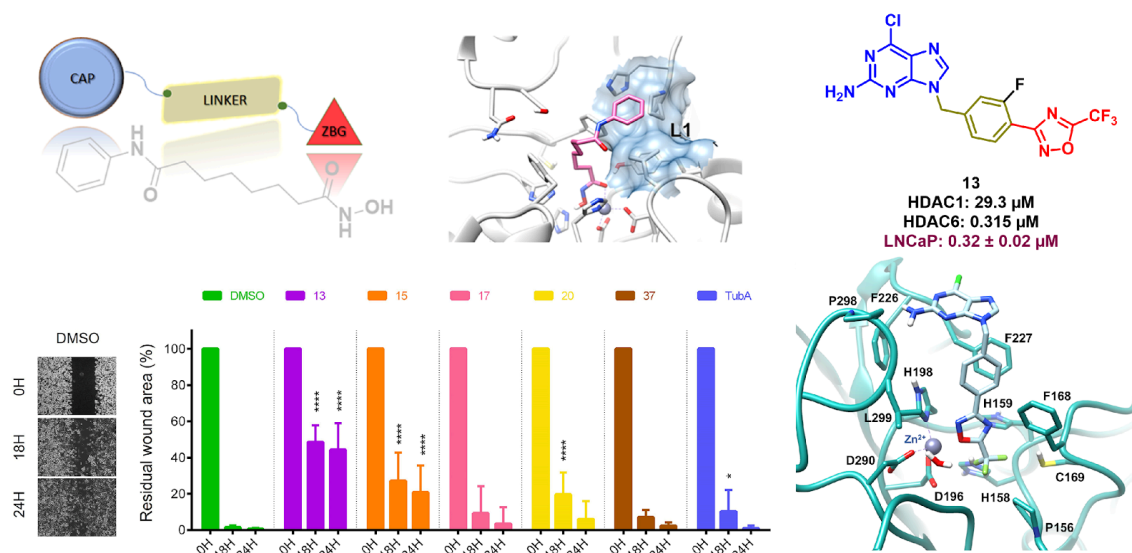

**Figure 1:** Chemical structure of the best candidate **13**, its anti-metastatic activity and its representative binding mode in complex with HDAC6

[1] P. Rawla, V. *World J. Oncol.* 10 (2019) 63-89;

[2] D. Bonanni, A. Citarella, D. Moi, L. Pinzi, E. Bergamini and G. Rastelli, *Curr. Med. Chem* 29 (2022) 1474-1502;

[3] D. Moi, D. Bonanni, S. Belluti, P. Linciano, A. Citarella, S. Franchini, C. Sorbi, C. Imbriano, L. Pinzi and G. Rastelli, *Eur. J. Med. Chem.* 260 (2023) 115730.

## Multifunctional agents to counteract Alzheimer's disease: a preliminary study

Bianca Laura Bernardoni,<sup>a</sup> Fabio Scianò,<sup>a</sup> Giovanni Petrarolo,<sup>a</sup> Lidia Ciccone,<sup>a</sup> Ilaria D'Agostino,<sup>a</sup> Susanna Nencetti,<sup>a</sup> Manuela Leri,<sup>b</sup> Monica Bucciattini,<sup>b</sup> and Concettina La Motta<sup>a</sup>

<sup>a</sup> Department of Pharmacy, University of Pisa, Via Bonanno, 6, I-56126 Pisa, Italy

<sup>b</sup> Department of Experimental and Clinical Biomedical Sciences "Mario Serio", University of Florence, Viale Morgagni 50, 50134 Florence, Italy

E-mail: [bianca.bernardoni@phd.unipi.it](mailto:bianca.bernardoni@phd.unipi.it)

Alzheimer's disease (AD) is a recognized multifaceted disorder. In addition to the well-established pathological hallmarks of AD,  $\beta$ -amyloid ( $A\beta$ ) plaques and hyperphosphorylated tau protein, increasing evidence links neuroinflammation, enhanced oxidative stress, and excessive metal ion accumulation to AD pathogenesis. In this context, SIRT1 has emerged as a potential preventive factor in AD, promoting brain homeostasis. This complex pathophysiology may explain the failures of many single-target therapies in clinical trials, leading to alternative therapeutic approaches that target multiple aspects of AD for additive or synergistic effects [1].

With this aim, we investigated a series of previously reported SIRT1 activators featuring a 2,6-diphenylimidazo[1,2-a]pyridine core, for anti-AD application [3]. We expanded the compounds library by decorating the phenyl rings with various methoxy and/or hydroxy groups. Due to their polyphenolic moieties, they exhibited good-to-strong antioxidant activity *in vitro*, as assessed via DPPH and ABTS assays, and TBARS colorimetric test using rat brain homogenate. Also, although with specific preferences, the compounds showed metal chelating ability towards  $Cu^{2+}$ ,  $Zn^{2+}$ , and  $Fe^{2+}$ . Notably, In differentiated SH-SY5Y cells, a model of AD, compound **CLM400** reduced oxidative stress at 2.5 nM, though a pro-oxidant effect was observed at 250 nM. Interestingly, TEM revealed the compounds' ability to form larger, non-toxic off-pathway aggregates, in line with literature. Indeed, although common anti-AD therapies aim at inhibiting  $A\beta$  aggregation into toxic soluble  $A\beta$  oligomers, recently, pro-aggregating compounds have been reported to be beneficial for the disease. This preliminary study highlighted a new series of multifunctional agents as promising tools for AD treatment. However, in-depth studies are required to shed light on the formed aggregates.

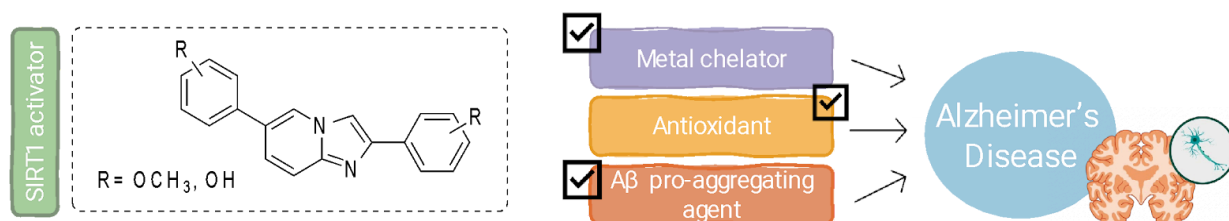

**Figure 1:** General structure and properties of novel multifunctional agents.

[1] A. R. Monteiro, D. J. Barbosa, F. Remiao and R. Silva, *Biochem Pharmacol*, (2023), 211, 115522.

[2] M. Watroba and D. Szukiewicz, *Front Physiol*, (2022), 13, 962769.

[3] L. Flori, G. Petrarolo, S. Brogi, C. La Motta, L. Testai and V. Calderone, *Eur J Pharm Sci*, (2021), 165, 105930.

**Luminescent micro- and nanostructures from the combination of organic fluorophores and microalgae**

Vincenzo Tedeschi,<sup>a</sup> Alessandro Digregorio,<sup>a</sup> César Vicente-García,<sup>a</sup> Annarita Flemma,<sup>a</sup> Sergio Macchioni,<sup>b</sup> Vincenzo Reggioni,<sup>b</sup> Danilo Vona,<sup>c</sup> Stefania Roberta Cicco,<sup>d</sup> Pietro Cotugno,<sup>a</sup> Roberta Ragni,<sup>a</sup> and Gianluca Maria Farinola<sup>a</sup>

<sup>a</sup> *Dipartimento di Chimica, Università degli studi di Bari Aldo Moro, via Orabona 4, 70126-Bari, Italy*

<sup>b</sup> *Hangar Lab Srl, via Mirandola 37a, 37026-Settimo, Italy*

<sup>c</sup> *Dipartimento di Scienze del Suolo, della Pianta e degli Alimenti (Di.S.S.P.A.), Università degli studi di Bari Aldo Moro, via Amendola 165/a, 70126-Bari, Italy*

<sup>d</sup> *Istituto di Chimica dei Composti Organometallici (ICCOM), CNR, via Orabona 4, 70126-Bari, Italy*  
E-mail: [vincenzo.tedeschi@uniba.it](mailto:vincenzo.tedeschi@uniba.it)

Among the living organisms that generate nanostructured components, diatoms are very attractive. Diatoms are a large and prolific class of single cell photosynthetic microalgae, whose mesoporous biomineralized silica shells (frustules) encase the organic protoplasm [1]. Frustules exhibit interesting properties such as high surface area, mechanical resistance, unique optical features and mesoporosity, which make them appealing materials for applications in photonics, sensing, optoelectronics and biomedicine. The availability of numerous chemical and biological approaches to modify the frustules composition represents a powerful resource to produce nanostructured materials with properties tailored for specific applications [2]. Chemically modified frustules with organic dyes have seldom been investigated for their optical properties thus far. We have demonstrated that in vivo incorporation of organic molecular emitters into frustules through biosilica biomineralization represents an efficient biotechnological route to produce new photonic materials whose properties come from the envisaging combination of the frustule hierarchical nanostructure with the luminescence of incorporated emitting molecules [3]. In particular, our study points out that the functionalization of diatoms biosilica with tailored photoactive molecules can represent a powerful tool in order to obtain luminescent micro- and nanostructured biomaterials for applications in biomedicine, optics, photonics and agriculture technologies.

[1] R. Ragni, S. R. Cicco, D. Vona, and G. M. Farinola, *Green Materials for Electronics* Ch. 11 (2017)

[2] R. Ragni, S. R. Cicco, D. Vona, and G. M. Farinola, *Adv. Mater.* 30 (2017) 1704289-1704302

[3] R. Ragni, F. Scotognella, D. Vona, L. Moretti, E. Altamura, G. Cecccone, D. Mehn, S. R. Cicco, F. Palumbo, G. Lanzani, and G. M. Farinola, *Adv. Funct. Mater.* 28 (2018) 1706214-1706223

---

## OR037

### Halloysite as innovative pyrazole[3,4-d]pyrimidine derivatives carrier for potential local treatment of prostate cancer

Rebecca Ciani,<sup>a</sup> Marina Massaro,<sup>a</sup> Anna Carbone,<sup>b</sup> Raquel de Melo Barbosa,<sup>c</sup> Giancarlo Grossi,<sup>b</sup> Rita Sánchez-Espejo,<sup>d</sup> Silvia Schenone,<sup>b</sup> Riccardo Vago,<sup>e</sup> Cesar Viseras Iborra,<sup>d,f</sup>, and Serena Riela<sup>g</sup>

<sup>a</sup> *Dipartimento di Scienze e Tecnologie Biologiche, Chimiche e Farmaceutiche (STEBICEF), Università degli Studi di Palermo, V.le delle Scienze, Ed. 17, 90128-Palermo, Italy.*

<sup>b</sup> *Dipartimento di Farmacia, Università degli Studi di Genova, V.le Benedetto XV, 16132-Genova, Italy.*

<sup>c</sup> *Department of Pharmacy and Pharmaceutical Technology, School of Pharmacy, University of Seville, C/Professor García González, 2, 41012-Seville, Spain.*

<sup>d</sup> *Department of Pharmacy and Pharmaceutical Technology, Faculty of Pharmacy, University of Granada 1807-Granada, Spain.*

<sup>e</sup> *Istituto San Raffaele (IRCCS), Istituto di Ricerca Urologica, Divisione di Oncologia Sperimentale, 20132-Milano, Italy.*

<sup>f</sup> *Andalusian Institute of Earth Sciences, CSIC-UGR. Avenida de las Palmeras 4, 18100-Granada, Spain.*

<sup>g</sup> *Università di Catania, Dipartimento di Chimica, Via Andrea Doria 6, 95125-Catania, Italy.*

E-mail: [rebecca.ciani@unipa.it](mailto:rebecca.ciani@unipa.it)

Prostate cancer is one of the most prevalent forms of cancer affecting men worldwide, representing a significant health concern due to its high incidence and potential for severe outcomes. Like numerous types of cancer, it frequently develops a dependence on growth factor receptors and their downstream signaling messengers, such as c-Src, which can be clinically targeted for treatment. Over the years, several c-Src inhibitors containing heterocyclic rings, such as pyrazolo[3,4-d]pyrimidine derivatives, have been studied. However, these compounds, like most anticancer drugs, exhibit very poor water solubility, leading to suboptimal drug delivery. Recently, the use of halloysite in the biomedical field has gained attention due to its bio- and eco-compatibility, low cost and natural availability. With its tubular morphology and possibility of surfaces modification, it presents a potential carrier for hydrophobic drugs [1], [2]. Herein, we report the design of halloysite-based nanomaterials covalently or supramolecularly modified with some *ad hoc* synthesized pyrazolo[3,4-d]pyrimidine derivatives. The obtained nanomaterials were thoroughly investigated from a physico-chemical point of view to assess the successful modification, and their morphology was imaged by transmission electron microscopy. Furthermore, their antiproliferative activity was also assessed through *in vitro* studies on RT112, UMUC3 and PC3 cell lines as model of bladder and prostate cancer cells.

[1] M. Massaro, G. Barone, V. Barra, P. Cancemi, A. Di Leonardo, G. Grossi, F. Lo Celso, S. Schenone, C. Viseras Iborra, and S. Riela, *Int. J. Pharm.* 599 (2021) 120281.

[2] M. Notarbartolo, M. Massaro, R. de Melo Barbosa, C. Emili, L. F. Liotta, P. Poma, F. M. Raymo, R. Sánchez-Espejo, R. Vago, C. Viseras-Iborra, and S. Riela, *Coll. Surf. B* 220 (2022) 112931

## Cellulose-based nanostructured aerogels for leachate decontamination: towards sustainable phosphorus recovery from sewage sludge ash

Laura Riva,<sup>a</sup> Gaia Boniardi,<sup>b</sup> Alessandro Volonterio,<sup>a</sup> Roberto Canziani,<sup>b</sup>  
Carlo Punta,<sup>a</sup> and Andrea Turolla<sup>b</sup>

<sup>a</sup> Department of Chemistry, Materials, and Chemical Engineering “G. Natta” and INSTM Local Unit,  
Politecnico di Milano, via Luigi Mancinelli 7, 20131 Milano, Italy

<sup>b</sup> Department of Civil and Environmental Engineering (DICA), Environmental Section,  
Politecnico di Milano, Piazza Leonardo da Vinci 32, 20133 Milano, Italy

E-mail: laura2.riva@polimi.it

The most recent indications from European Union data classify phosphorus as a critical raw material. Efficient techniques for recovering phosphorus (P) from sewage sludge ash *via* wet chemical extraction followed by precipitation have been refined, being the co-dissolution of metals besides P from ash the main challenge to overcome [1].

Herein we propose an effective and sustainable decontamination strategy for sewage sludge ash derived leachate using eco-safe cellulose-based nanostructured aerogels (CNS), synthesized by the 2,2,6,6-Tetramethylpiperidin-1-yl)oxyl (TEMPO)-oxidation of cotton-derived cellulose subjected to ultrasonication and thermal cross-linking with branched polyethylenimine (bPEI) [2,3]. Lab-scale adsorption tests were conducted with different amounts of CNS (1, 3 and 10 g<sub>CNS</sub>/L in absence or presence of citric acid (10 g/L)) at different pH values in the range between 1.5 and 10, where P and metals content (As, Cu, Cr, Ni, Zn, Fe, Al) was monitored. P was then precipitated from the decontaminated leachate by Ca(OH)<sub>2</sub> till target pH.

Results showed that CNS were able to adsorb considerable amounts of metallic ions, in particular Fe and Al, under strongly acidic conditions, reducing their percentage by 40% and 30%, respectively. The solid precipitate recovered at pH 8 from the decontaminated leachate (obtained after addition of 10 g<sub>citric acid</sub>/L and 10 g<sub>CNS</sub>/L), was compliant with EU regulation 2019/1009 in terms of P<sub>2</sub>O<sub>5</sub> and heavy metals content, suggesting its possible use as raw material for inorganic fertilizers production.

[1] G. Boniardi, A. Turolla, A., L. Fiameni, E. Gelmi, F. Malpei, E. Bontempi, and R. Canziani, *Chemosphere* 85 (2021) 131476

[2] A. Fiorati, G. Grassi, A. Graziano, G. Liberatori, N. Pastori, L. Melone, L. Bonciani, L. Pontorno, C. Punta, and I. Corsi, *J. Clean. Prod.* 246 (2020) 119009

[3] L. Riva, N. Pastori, A. Panozzo, M. Antonelli, and C. Punta., *Nanomaterials* 10 (2020) 1–18

## Surface amidated TEMPO-CNF films for dyes and drugs adsorption

Domenico Santandrea,<sup>a</sup> Cecile Sillard,<sup>b</sup> Valentina Beghetto<sup>a</sup> and Julien Bras<sup>b</sup>

<sup>a</sup> Ca'Foscari University of Venice, Department of Molecular Sciences and Nanosystems, Via Torino 155, Venice, Italy

<sup>b</sup> Université Grenoble Alpes, CNRS, Grenoble INP, LGP2, 461 Rue de la Papeterie, Grenoble, France  
E-mail: [domenico.santandrea@unive.it](mailto:domenico.santandrea@unive.it)

Water pollution is a major concern in most developing nations which are dealing with a severe issue having significant influences on human health, environment and aquatic systems. According to the World Health Organization (WHO), half of the world's population will be living in water-stressed areas by 2025 (WHO/UNICEF, 2019) [1]. Among the different techniques explored, water purification through adsorption has emerged as a suitable alternative for the removal of toxic molecules [2]. Thanks to its abundance in nature, its non-toxicity and its biodegradability, cellulose and its derivatives constitute a promising adsorbent material for this type of applications. Within this panorama, an adsorbent material based on oxidized cellulose nanofibrils (TEMPO-CNF) has been prepared by chemical functionalization with benzylamine for the adsorption of two model molecules, methylene blue (MB) and chlorhexidine digluconate (CHX). The material obtained appears to be efficient, with a maximum absorption of MB equal to 120 mg/g and CHX equal to 292 mg/g, easily recoverable, washable and reusable (Fig. 1). Finally, the bio fragmentation of the material was studied to evaluate the possible effects of the chemical graft on the fibers.

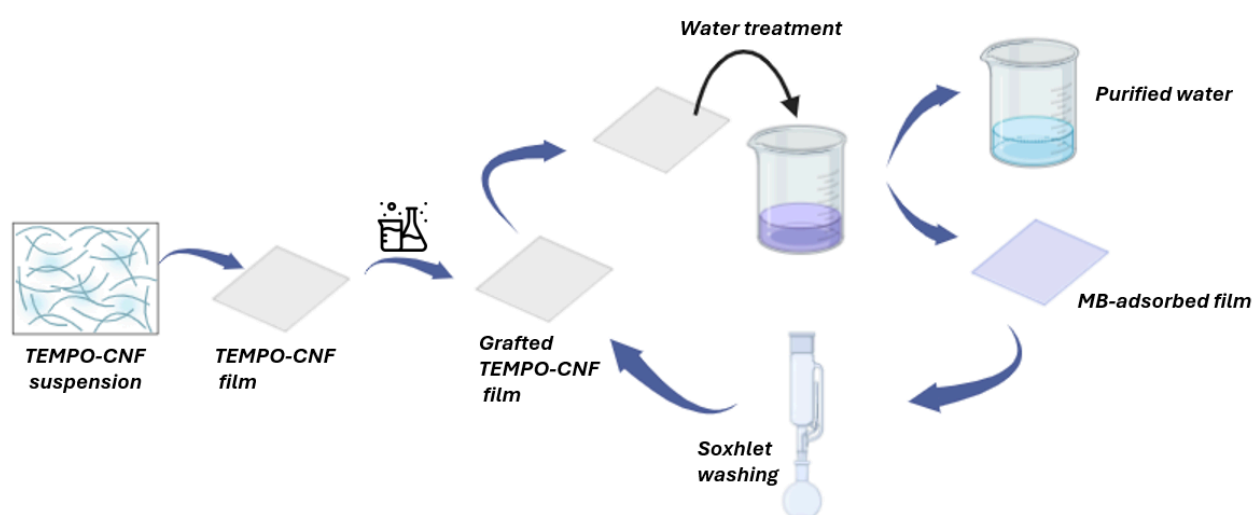

**Figure 1:** Grafted TEMPO-CNF film for water purification

[1] A.S. Norfarhana, R.A. Ilyas, and N. Ngadi, *Carbohydrate Polymers* 291 (2022) 119563

[2] T. Shahnaz, D. Bedadeep, and S. Narayanasami, *Int. J. Biol. Macromol.* 200 (2022) 162–171

## Activity of single atom catalyst for nitrogen reduction: the more reactive the better does not always holds true

Matteo Spotti, Ilaria Barlocco, Giovanni Di Liberto, and Gianfranco Pacchioni

Department of Materials Science, University of Milano-Bicocca, Via Roberto Cozzi 55, I-20125 Milan, Italy  
E-mail: [m.spotti1@campus.unimib.it](mailto:m.spotti1@campus.unimib.it)

Single Atom Catalysts (SACs) are emerging as a new frontier in heterogeneous catalysis [1]. They are made of metal atoms atomically dispersed on a matrix. Computational chemistry allows to study catalytic processes with an atomic detail and to rationalise, and even predict, the properties of systems. A lot of attention has been dedicated to the electrochemical Nitrogen Reduction Reaction (NRR) to ammonia, because of the key role that it could have in energy transition [2]. The activity of SACs is usually rationalized by using the Computational Hydrogen Electrode (CHE), a thermodynamic approach proposed by Nørskov and co-workers, making possible to explain the catalytic activity evaluating Gibbs free energies of key adsorbed intermediates [3]. In this presentation we rationalise the activity of Single and Dual Atom Catalysts made of a set of transition metal atoms for NRR. We show the importance of using self-interaction corrected functionals. We also observed that DACs are more active than SACs, an aspect in line with the nature of the real catalyst (nitrogenase) for NRR in ambient condition. Also, the highest thermodynamic barrier decreases from 3d to 5d metals. Interestingly, if one combines the two positive effects, this results into too strongly stable intermediates, showing that “*the more reactive the better*” does not always hold true in single atom catalysis. We, finally, show that the NRR mechanism cannot be limited to the classical. This work highlights *i)* the importance of using self-interaction corrected functionals, *ii)* DACs could be a valid option for NRR, and *iii)* the combined effect of DACs with 5d metals does not necessarily lead to an increment of the activity.

[1] G. Di Liberto, G. Pacchioni, 2023, Adv. Mater., 35, 2307150

[2] X. Y. Cui, C. Tang, Q. Zhang, 2018, Adv. Energy Mater., 8, 1800369

[3] J. K. Nørskov et al, 2002, J. Catal., 209, 275-278

## OR041

### Copper/carbon composite waste from the automotive industry as a multiplatform for thermal and electrocatalyst

Stefano Di Giacomo<sup>a</sup>, Tom Burwell<sup>b</sup>, Andrei N. Khlobystov<sup>b</sup>, and Antonella Fontana<sup>a,c,d</sup>

<sup>a</sup> Department of Pharmacy, University "G. d'Annunzio", Via dei Vestini 31, 66100, Chieti, Italy

<sup>b</sup> School of Chemistry, University Park, University of Nottingham, Nottingham NG7 2RD, UK

<sup>c</sup> INSTM consortium, Via Giusti 9, 50121, Firenze, Italy

<sup>d</sup> UdA-TechLab, Research Center, University "G. d'Annunzio", 66100 Chieti, Italy

E-mail: [stefano.digiacomo@unich.it](mailto:stefano.digiacomo@unich.it)

Raw materials have many applications, and recycling is crucial for the European economy. The EU Commission has classified graphite and copper as critical raw materials. This study uses recycled graphite/copper composite from waste materials from an automotive spare parts company as a multiplatform catalyst. Specifically, it has been successfully used in the Ullmann reaction to produce indole-based intermediates of pharmaceutical interest. The Ullmann reaction, first introduced in 1901, involves the coupling of aryl halides using copper as a catalyst. Using our catalyst allowed us to perform the reaction under mild conditions, exploiting waste material as an efficient catalyst. The same waste material, after additional processing, was investigated for electrocatalysis of carbon dioxide (CO<sub>2</sub>) reduction. CO<sub>2</sub> is one of our planet's most significant and enduring greenhouse gases, and converting CO<sub>2</sub> into hydrocarbon fuels or other valuable chemicals is a promising and environmentally effective valorisation process. This reduction can be achieved through electrocatalysis[1], but there are challenges with the efficiency and cost of the catalyst, which could pose serious drawbacks. In this work, we reached 35% faradaic efficiency towards ethanol using waste dendritic copper/graphite and demonstrated reuse of it several times. In summary, these two catalytic processes are only two examples of how waste material, adequately modified, processed, and characterized, could be used as an effective multiplatform catalyst.

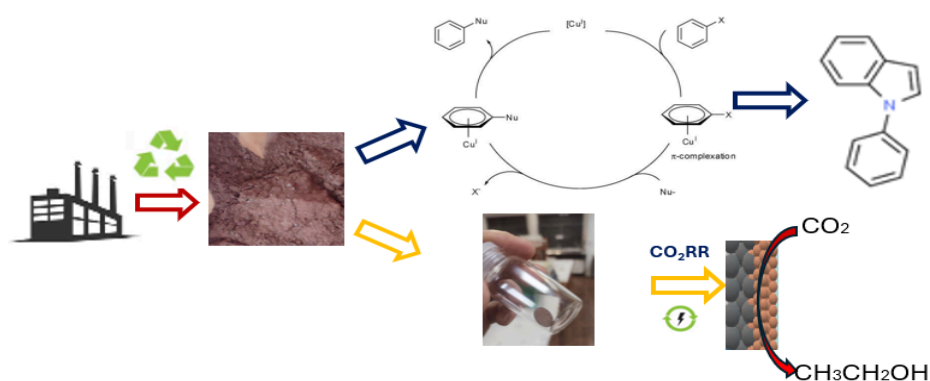

**Figure 1:** Waste utilization.

[1] J. Yu, J. Wang, Y. Ma, J. Zhou, Y. Wang, P. Lu, J. Yin, R. Ye, Z. Zhu, Z. Fan, Adv. Func. Mat. 31 (2021) 2102151

**Key ingredients for the screening of single atom catalysts for the hydrogen evolution reaction: the case of titanium nitride**

Clara Saetta, Ilaria Barlocco, Giovanni Di Liberto, and Gianfranco Pacchioni

*Dipartimento di Scienza dei Materiali, Università degli studi di Milano Bicocca  
Via R. Cozzi 55, 20125-Milano, Italy**E-mail: [c.saetta@campus.unimib.it](mailto:c.saetta@campus.unimib.it)*

Single Atom Catalysts (SACs) are considered a new frontier in the field since they establish a bridge between homogeneous and heterogeneous catalysis. Computational chemistry allows to access the atomistic details of catalytic processes, and it is extremely helpful to rationalize or even predict the properties of systems. A lot of attention has been dedicated to the reactions of evolution and conversion of molecular hydrogen and oxygen from or to liquid water [1]. The Computational Hydrogen Electrode (CHE) approach is well established to predict the activity of catalytic materials and was originally developed to study reactions on extended surfaces. In this approach the free energy of key intermediates adsorbed is used to explain the catalytic activity, or even to predict new potential candidates. In recent years, this framework was directly transferred and applied to SACs, although their reactivity differs from extended systems. In this speech we discuss a computational screening of Single Atom Catalysts (SACs) bound to titanium nitride (TiN), an emerging supporting matrix. The catalysts were tested against the Hydrogen Evolution Reaction (HER), based on density functional theory (DFT). We show the role of fundamental ingredients to consider for a reliable screening of SACs, that are typically neglected. Namely, the formation of H<sub>2</sub>-complexes [2] besides the classical H\* one has an important impact on the predicted HER activity. Also, the results indicate that one needs to adopt self-interaction corrected functionals [3]. Once unconventional intermediates in a self-interaction corrected scheme, the number of potential good catalysts for HER is strongly reduced, since the formation of unconventional intermediates lead to thermodynamic barriers. This study highlights the importance of including the key ingredients for the prediction of new systems, such as the formation of unconventional intermediates and the adoption of self-interaction corrected functionals. Also, this study highlights some interesting candidate deserving more dedicated work.

- [1] L. Cao, Q. Luo, W. Liu, Y. Lin, X. Liu, Y. Cao, W. Zhang, Y. Wu, J. Yang, T. Yao, S. Wei, *Nat. Catal.* 2 (2019) 134.  
[2] Di Liberto, Giovanni, Luis A. Cipriano, and Gianfranco Pacchioni. *JACS* 143.48 (2021) 20431-20441  
[3] I. Barlocco, L.A. Cipriano, G. Di Liberto, G. Pacchioni. *Adv. Theo. & Simul.* 6, 2200513 (2023)

## Continuous flow telescoped synthesis of Levetiracetam

Marco Fattalini, Eleonora Colombo, Monica Boselli, and Maurizio Benaglia

Dipartimento di Chimica, Università degli Studi di Milano, Via Golgi 19, Milan, Italy  
E-mail: [marco.fattalini@unimi.it](mailto:marco.fattalini@unimi.it)

Levetiracetam is an antiepileptic drug approved by the Food and Drug Administration in 1999. It is one of the best drugs sold, and many efforts are made for the development of new and more efficient synthesis providing this bioactive molecule.

To develop innovative synthetic strategies based on renewable and environmentally friendly resources, photocatalysis and flow chemistry emerges as victorious strategies to introduce novel and intriguing synthetic methodologies with reduced environmental impact and increased efficiency.

In this work, we report the development of a continuous flow telescoped process for the synthesis of Levetiracetam. The telescoped process is divided into three different stages, that are all merged in a single continuous process.

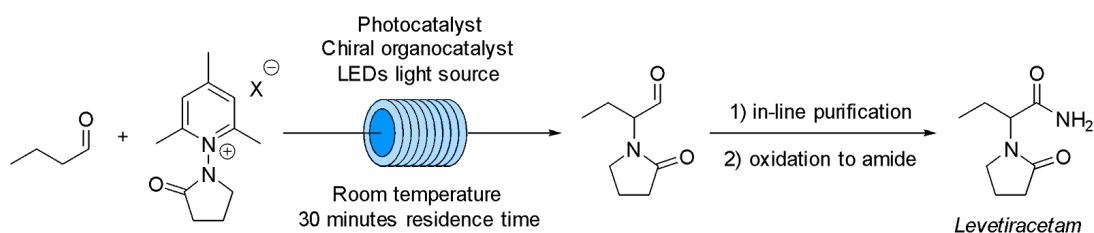

**Figure 1:** Continuous flow telescoped process for the synthesis of Levetiracetam

In the first step the  $\beta$ -lactam moiety is added to a cheap and abundant starting aldehyde through a photocatalytic strategy that enables the direct stereoselective introduction of the lactam ring, via nitrogen radicals. To the best of our knowledge, in the literature no example of nitrogen radical localized on lactam rings is described [1]: the innovative strategy proposed in this work, that combines photocatalysis and organocatalysis, was developed in our research group [2] by taking inspiration from a work of MacMillan and coworkers [3]. The desired aldehyde is obtained in a good yield and excellent enantiomeric excess. In the second stage, the continuous stream resulting from the first reaction stage is purified, using an in-line separator. Finally, in the third stage, the obtained aldehyde is oxidized to the corresponding amide that represents the target compound itself.

Levetiracetam is achieved in a continuous telescoped process, with productivities and space-time yields improved with respect to the corresponding conventional batch procedure, exploiting an innovative synthetic methodology not known in literature.

[1] J. Davies, S.P. Morcillo, J.J. Douglas, and D. Leonori, *Chem. Eur. J.* 24 (2018) 12154-12163.

[2] M.F. Boselli, N. Intini, A. Puglisi, L. Raimondi, S. Rossi, and M. Benaglia, *Eur. J. Org. Chem.* (2023) e202201309.

[3] G. Cecere, C.M. König, J. L. Alleva, and D.W.C. MacMillan, *JACS* 135 (2013) 11521-11524.

## Water oxidation: the role of new iron-based N-heterocyclic carbene complexes

Chiara Lenzi,<sup>a,b</sup> Alessandro Messori,<sup>a,b</sup> Giada D'Altri,<sup>a</sup> Isacco Gualandi,<sup>a,b</sup> Erika Scavetta,<sup>a,b</sup> Rita Mazzoni<sup>a,b</sup>

<sup>a</sup> Dep. of Industrial Chemistry "Toso Montanari", via Piero Gobetti 85, 40129 Bologna, Italy

<sup>b</sup> Center for Chemical Catalysis – C3, University of Bologna, via Piero Gobetti 85, 40129 Bologna, Italy  
E-mail: [chiara.lenzi12@unibo.it](mailto:chiara.lenzi12@unibo.it)

Water splitting is a pivotal reaction in the development of innovative green energy sources which aims to produce molecular oxygen (O<sub>2</sub>) and molecular hydrogen (H<sub>2</sub>).

In the first mentioned product, the use of water oxidation catalysts [1] (WOCs) is necessary to overcome the high overpotential associated with this process. Instead of systems based on rare and expensive metals, cheaper alternatives based on iron have been explored in the field of electrocatalysis, but multiple issues have been met such as high overpotentials and low activities. Our research group addressed this challenge by designing and synthesizing an iron N-heterocyclic carbene (NHC) complex, which exhibits competitive activity and low overpotential under basic conditions [2]. The main aim is designing novel and effective synthetic routes for obtaining iron complexes with variously substituted cyclopentadienonic (CpO) and NHC ligands, which may be promising candidates as heterogeneous catalysts for the WOR (Figure 1). NHC ligands, which feature a pyrenic group, are purposefully designed for an easy immobilization on a Glassy Carbon working electrode. These complexes, characterized by NMR, IR, UV-vis absorption, ESI-MS, and Cyclic Voltammetry, are studied in both their homogeneous and immobilized form during cyclic voltammetry analyses.

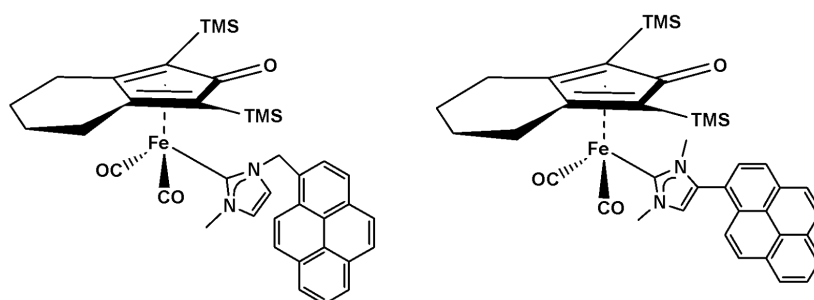

**Figure 1:** Synthesized Fe<sup>0</sup> complexes with CpO and NHC ligands

Acknowledgments: Authors wish to acknowledge PRIN 2022 "Biomass-derived alcohols and polyols valorization and use by dehydrogenation/hydrogenation reactions promoted by bifunctional, proton-responsive homogeneous catalysts (ALCOVAL)" CUP J53D23008500006 for financial support.



[1] Den Boer, D.; Hetterscheid, D. G. H. Design Principles for Homogeneous Water Oxidation Catalysts Based on First-Row Transition Metals. *Curr. Opin. Electrochem.* 2022, 35, 101064

[2] Cingolani, A, et al. Cyclopentadienone–NHC Iron(0) Complexes as Low Valent Electrocatalysts for Water Oxidation. *Catal. Sci. Technol.* 2021, 11 (4), 1407–1418.

## Photoconversion of CO<sub>2</sub> to fuels under high pressure

Simge Naz Degerli,<sup>a</sup> Matteo Tommasi,<sup>b</sup> Alice Gramegna,<sup>a</sup> Gianguido Ramis,<sup>c</sup> and Ilenia Rossetti<sup>a,b</sup>

<sup>a</sup> *INSTM Unit Milano-Università, via C. Golgi 19, 20133 Milan, Italy*

<sup>b</sup> *Department of Chemistry, Università degli Studi di Milano, via C. Golgi 19, 20133 Milan, Italy*

<sup>c</sup> *Department of Civil, Chemical and Environmental Engineering, Università degli Studi di Genova and INSTM Unit Genova, via all'Opera Pia 15A, 16145 Genoa, Italy*

[simge.naz.degerli@guest.unimi.it](mailto:simge.naz.degerli@guest.unimi.it)

The world is currently confronted with a complex array of critical global crises, including global warming, rising sea levels, glacier melt and extreme weather events such as floods, wildfires and droughts, along with decline in agricultural yields. Among various approaches, CO<sub>2</sub> photoreduction (CO<sub>2</sub>PR) stands out as particularly promising. This method leverages renewable solar energy to produce clean fuels and value-added chemicals, such as methane, methanol and formic acid [1]. In this study, an innovative high-pressure batch photoreactor was employed for the photoreduction of CO<sub>2</sub> at a constant temperature of 80 °C. This reactor, capable of operating at pressure up to 20 bar, was constructed from AISI 316 stainless steel and featured an internal capacity of 1.7 liters, facilitating semi-pilot scale demonstration. It was equipped with a magnetic stirrer and a double-walled thermostatic system. A 250 W medium-pressure Hg vapor lamp was positioned vertically along the reactor axis to serve as the irradiation source. The optimal reaction time was determined to be 1.5 hours. Sodium sulphite was utilized as a hole scavenger, leading to maximum productivity. The reaction was carried out at pH=14 which promoted 100% selectivity for HCOOH as the product. Environmentally friendly graphitic carbon nitride was used as a photocatalyst to avoid the use of toxic and rare materials. Different preparation methods were evaluated, comparing its exfoliation through thermal, chemical and ultrasound treatments. The semiconductor was also functionalized with different oxides in a Z-scheme configuration, such as ZnO, SnO<sub>2</sub> and Fe<sub>2</sub>O<sub>3</sub> with different loadings. Among them, the hybrid 8 wt% Fe<sub>2</sub>O<sub>3</sub>/g-CN photocatalyst achieved ca. 8 mol/kg<sub>cat</sub> h of HCOOH, compared to ca. 6 mol/kg<sub>cat</sub> h of the bare g-CN. The synthesized catalysts were characterized using XRD, BET, DRS, TEM and SEM techniques.

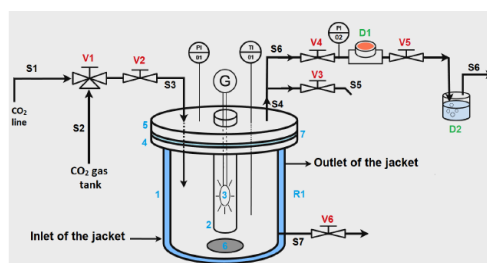

**Figure 1:** Demonstration of the structure of the high pressure photoreactor.

### Acknowledgements

The research was funded by Fondazione Cariplo through the grant 2021-0855 – “SCORE - Solar Energy for Circular CO<sub>2</sub> Photoconversion and Chemicals Regeneration”, Circular Economy call 2021 and by MUR within the project “P20227LB45 - SCORE2 - Solar-driven Conversion of CO<sub>2</sub> with HP-HT photoreactor”, call PRIN2022PNRR.

[1] A. Anus, S. Park, Chem. Eng. J. 486 (2024) 150213.

## OR046

### Nitrogen-rich carbon dots in asymmetric nano-organocatalysis *via* ACDC

Alessio Carioscia,<sup>a</sup> Emanuele Cocco,<sup>a</sup> Maria Edith Casacchia,<sup>a,b</sup> Giuseppe Gentile,<sup>c</sup> Martina Mamone,<sup>c</sup> Giuliana Giorgianni,<sup>a</sup> Elena Incerto,<sup>a</sup> Maurizio Prato,<sup>\* c,d,e</sup> Fabio Pescioli,<sup>\* a</sup> Giacomo Filippini,<sup>\* c</sup> and Armando Carlone<sup>\* a,f</sup>

<sup>a</sup> Department of Physical and Chemical Sciences, Università degli Studi dell'Aquila, Via Vetoio, 67100, L'Aquila, Italy

<sup>b</sup> IUSS Scuola Universitaria Superiore di Pavia, Palazzo del Broletto, Piazza della Vittoria, 15, 27100, Pavia, Italy

<sup>c</sup> Department of Chemical and Pharmaceutical Sciences, INSTM UdR Trieste, University of Trieste, via Licio Giorgieri 1, 34127 Trieste, Italy

<sup>d</sup> Centre for Cooperative Research in Biomaterials (CIC BiomaGUNE), Basque Research and Technology Alliance (BRTA), Paseo de Miramón 194, 20014, Donostia San Sebastián, Spain

<sup>e</sup> Basque Fdn Sci, Ikerbasque, 48013 Bilbao, Spain

<sup>f</sup> INSTM, Consorzio Nazionale per la Scienza e Tecnologia dei Materiali, RU L'Aquila  
E-mail: alessio.carioscia@graduate.univaq.it

Nowadays, nanomaterials are gaining traction for advancing technology and for enhancing material properties, thus enabling innovations in medicine, electronics, and environmental sustainability due to their unique physical, chemical, and biological features. In this scenario, Carbon Dots (**CDs**) emerged as a new class of quasi-spherical nanomaterials which find broad applications in catalysis for their peculiar properties; successful applications in organocatalysis could be pivotal for the development of the field.

The presented study expands the research on Nitrogen-rich Carbon Dots as a powerful tool in Asymmetric Organocatalysis *via* LUMO-lowering, presenting the first design of a nano-derived catalytic salt able to control the stereoselectivity of the desired product *via* asymmetric counterion directed catalysis (ACDC). A correlation between the features of the **CDs**' surfaces and their catalytic performance was shown, and the catalytic activity of the employed **CDs** proved to be higher than simple molecular amines. An extensive reaction optimization allowed the reduction of different  $\alpha,\beta$ -unsaturated aldehydes in good yield and ee, using a low catalyst loading.

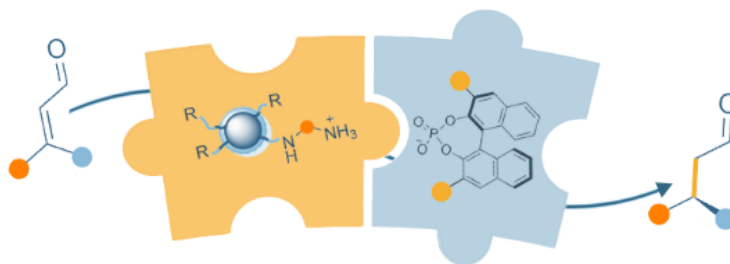

**Figure 1:** Reduction of  $\alpha,\beta$ -unsaturated aldehydes *via* Asymmetric Counterion Directed Catalysis employing Nitrogen-Rich Carbon Dots

## Zeolitic Imidazolate Framework-8 (ZIF-8) for antimicrobial prevention

Valentina Di Matteo,<sup>a</sup> Maria Cristina Cassani,<sup>a</sup> Barbara Ballarin,<sup>a</sup> Silvia Panzavolta,<sup>b</sup> Maria Francesca Di Filippo,<sup>b</sup> and Francesca Bonvicini<sup>c</sup>

<sup>a</sup> Dipartimento di Chimica Industriale "Toso Montanari", Alma Mater Studiorum Università di Bologna, Via Piero Gobetti 85, 40136-Bologna, Italy

<sup>b</sup> Dipartimento di Chimica "G. Ciamician", Alma Mater Studiorum Università di Bologna, Via Francesco Selmi 2, 40126-Bologna, Italy

<sup>c</sup> Dipartimento di Farmacia e Biotecnologie, Alma Mater Studiorum Università di Bologna, Via Massarenti 9, 40138-Bologna, Italy

E-mail: [valentina.dimatteo5@unibo.it](mailto:valentina.dimatteo5@unibo.it)

Zeolitic Imidazolate Framework-8, also known as ZIF-8, is a subclass of MOF formed by the self-assembly of zinc ions and 2-methylimidazole. Due to its unique characteristics, it has attracted attention in the biomedical field.

As illustrated in Figure 1, in this work we are presenting the use of ZIF-8 in different biomedical applications: a) fabrication of Cellulose/ZIF-8 patches for the management of wound infections [1]; b) modification of titanium scaffolds with ZIF-8 for bone substitution and regeneration [2]; c) encapsulation of snail slime extracted from *Helix aspersa muller* [3].

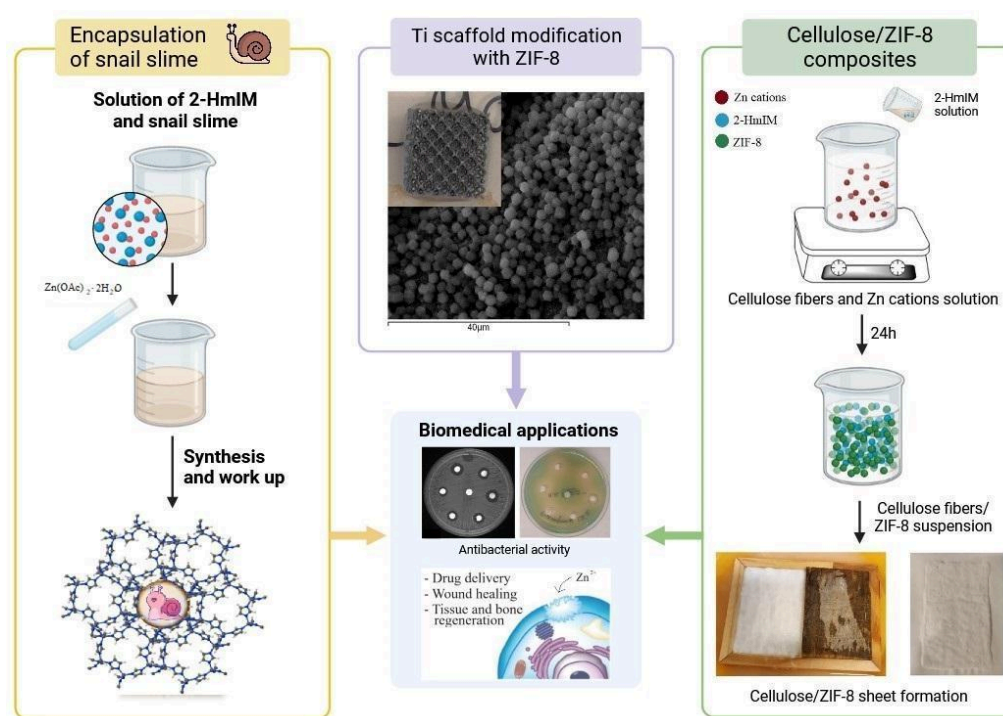

**Figure 1:** Schematic representation of the different research applications of ZIF-8.

[1] Di Matteo, V.; Di Filippo, M.F.; Ballarin, B.; Gentilomi, G.A.; Bonvicini, F.; Panzavolta, S.; Cassani, M.C., J. Funct. Biomater. 2023, 14, 472.

[2] Manuscript submitted for publication.

[3] Di Filippo, M.F.; Di Matteo, V.; Dolci, L.S.; Albertini, B.; Ballarin, B.; Cassani, M.C.; Passerini, N.; Gentilomi, G.A.; Bonvicini, F.; Panzavolta, S., Nanomaterials 2022, 12, 3447.

## Design of carbon nanoheaters enhancing tissue regeneration

Manuele Di Sante,<sup>a</sup> Matteo Di Giosia,<sup>a</sup> Claudia Tortiglione,<sup>b</sup> and Matteo Calvaresi <sup>a</sup>

<sup>a</sup> Dipartimento di Chimica “Giacomo Ciamician”, Università di Bologna, Via Francesco Selmi 2, 40126-Bologna, Italy

<sup>b</sup> Istituto di Scienze Applicate e Sistemi Intelligenti, Consiglio Nazionale delle Ricerche, Via Campi Flegrei 34, 80078-Pozzuoli, Italy

E-mail: manuele.disante2@unibo.it

The local delivery of a low heat dose can be exploited in regenerative medicine, augmenting tissue regeneration. Carbon Nanotubes (CNTs) are able to efficiently convert near infrared radiation (NIR) into heat and are under extensive investigation because of their potential as intracellular nanoheaters [1]. However, the use of CNTs in biological systems still presents important restrictions due to 1) low biocompatibility; 2) dependency of their properties and toxicity on the physiological environment and 3) the related aggregation phenomena.

Proteins can be used to disperse efficiently in water CNTs with a “green” supramolecular approach, minimizing undesirable toxic responses and controlling their biodistribution/cellular uptake [2].

Here we synthesized various CNT-protein hybrids using lysozyme and bovine serum albumin as model proteins and different CNTs (CNT(6,5) or COMOCAT). The protein platform offered different chemical groups for an easy route of functionalization of the hybrids (figure 1), that were engineered by cationization (using cationizing agents such as ethylenediamine), or covalently linking targeting agents (i.e. EGF protein) and fluorescent tags (i.e. Fluorescein isothiocyanate) [3].

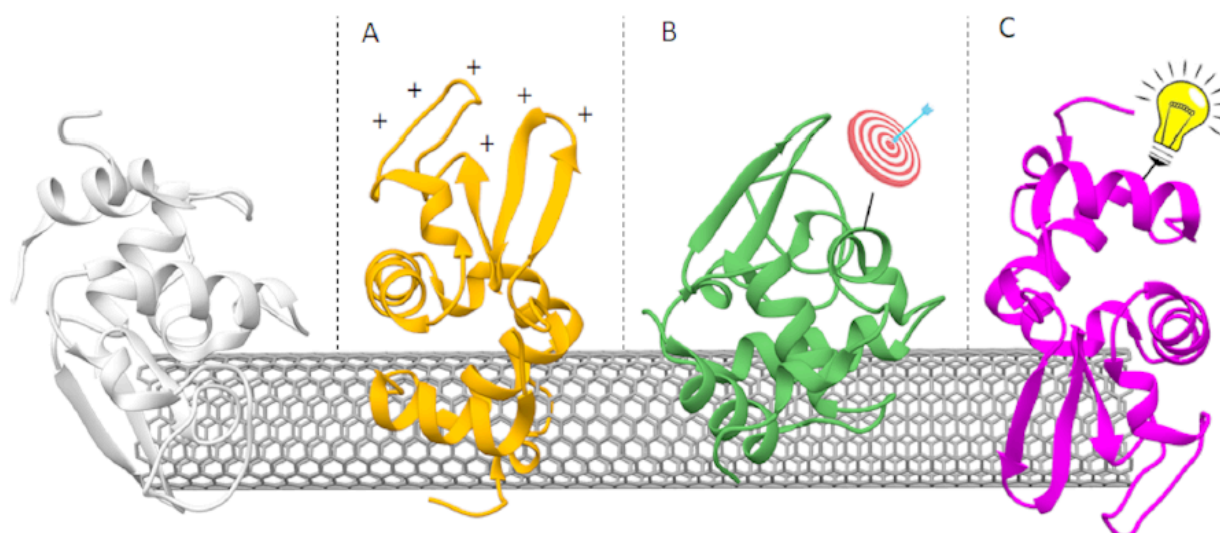

**Figure 1:** Engineering of CNT-Protein hybrids by cationization (A), bioconjugation of targeting agents (B) or fluorescent tags (C)

**Acknowledgment:** Funded by the European Union – NextGenerationEU, Phoenix: Enhancing tissue regeneration through carbon nanoheaters, P2022LE4BE, CUP B53D23031710001.

[1] R. Singh, S. V. Torti, *Advanced Drug Delivery Reviews*. 65 (2013) 2045-2060

[2] M. Calvaresi, F. Zerbetto, *Acc. Chem. Res.* 46 (2013) 2454-2463

[3] M. Di Giosia, F. Valle, A. Cantelli, A. Bottoni, F. Zerbetto, E. Fasoli and M. Calvaresi, *Carbon*. 147 (2019) 70-82

## Electrochemiluminescence imaging with Nanostructured electrode: A Platform for Enhanced Performance

Gabriele Giagu,<sup>a</sup> Chiara Mariani,<sup>a</sup> Davide Gramigni,<sup>a</sup> Alberto Bossi,<sup>b</sup> Alessandro Auditore,<sup>c</sup> Antonino Licciardiello,<sup>c</sup> Massimo Marcaccio,<sup>a</sup> Giovanni Valenti,<sup>a</sup> and Francesco Paolucci<sup>a</sup>

<sup>a</sup> Department of Chemistry “G. Ciamician”, University of Bologna, Via Selmi 2, 40126 Bologna, Italy;

<sup>b</sup> Istituto di Scienze e Tecnologie Chimiche “Giulio Natta” del Consiglio Nazionale delle Ricerche, CNR-SCITEC; Photoactive Molecular Materials & Devices Group, IT-20138 Milan, Italy;

<sup>c</sup> Dipartimento di Scienze Chimiche and CSGI, Università degli Studi di Catania, V.le A. Doria 6, I 95125, Catania, Italy.

Email: gabriele.giagu2@unibo.it

Electrogenerated chemiluminescence (ECL) is a light-emitting process driven by electrochemical reactions. ECL combines exceptional signal-to-noise ratio, high spatial resolution, and robust signal amplification [1]. ECL imaging is rapidly becoming a powerful instrument for probing cellular details at the single-entity level.

ECL imaging offers unprecedented potential to dissect cellular components and functions [2], but the use of traditional label-free 'shadow' ECL microscopy, which relies on highly efficient ECL generation through a catalytic process, for cell imaging can diminish image contrast.

Our proposal aims to enhance image contrast and resolution by employing immobilized luminophores rather than freely diffusing ones. Specifically, we propose a nanostructure consisting of two layers: one of bare TiO<sub>2</sub> nanoparticles and another of luminophore-doped TiO<sub>2</sub> nanoparticles [3].

Therefore, the thickness of the two layers can be precisely controlled to select different ECL generation mechanisms.

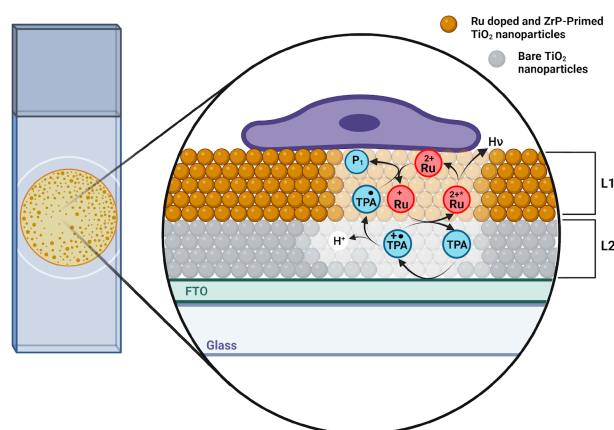

**Figure 1:** Scheme representing the nanostructured electrodes.

[1] Zanut, A., Fiorani, A., Canola, S. et al. Insights into the mechanism of coreactant electrochemiluminescence facilitating enhanced bioanalytical performance. *Nat Commun* 11, 2668 (2020).

[2] Giovanni Valenti, Sabina Scarabino, Bertrand Goudeau, Andreas Lesch, Milica Jović, Elena Villani, Milica Sentic, Stefania Rapino, Stéphane Arbault, Francesco Paolucci, and Neso Sojic *Journal of the American Chemical Society* **2017** 139 (46), 16830-16837

[3] S. Vitale, B. Laramée-Milette, A. Valenti, M. E. Amato, G. S. Hanan, N. Tuccitto, and A. Licciardiello, *J. Vac. Sci. Technol. B* 38, 032802 (2020).

## Proteins as carriers for photodynamic therapy

Alessia Marconi, Edoardo Jun Mattioli, Matteo Di Giosia, and Matteo Calvaresi

*Dipartimento di Chimica "Giacomo Ciamician", Alma Mater Studiorum- Università di Bologna, via Francesco Selmi 2, Bologna 40126.*

*E-mail: [alessia.marconi5@unibo.it](mailto:alessia.marconi5@unibo.it)*

Photodynamic therapy (PDT) is a clinically approved procedure for treating different types of cancer with high selectivity and minimal side effects. PDT utilizes light to activate a photosensitizing agent (PS) and achieve therapeutic effects through the local generation of reactive oxygen species (ROS).

Most photosensitizers suffer from low solubility, tendency to aggregate in aqueous media, poor biocompatibility, and cell toxicity, hampering the full exploitation of their potential in nanomedicine. We demonstrated the possibility of using proteins as versatile carriers for photosensitizers [1], both via covalent conjugation and supramolecular interactions. Due to the intrinsic biocompatibility of the proteins, their physiological stability, and lack of immunogenicity protein-based theranostics nanoplatfroms meet the strict requirements for biomedical usage [2].

Human serum albumin (HSA) is the natural carrier of many hydrophobic endogenous and exogenous compounds. Due to the enhanced permeability and retention effect (EPR), as well as the presence of HSA receptors overexpressed on cancer cells, albumin-based formulations can be exploited as a tumor-selective drug delivery system (DDS). These characteristics along with its abundance in human plasma make HSA a good candidate to act as DDS for hydrophobic PSs. In our group, the interactions of several plasma proteins (i.e., HSA, myoglobin) with different PSs (i.e., Chlorin e6 and Temoporfin) were studied both computationally and experimentally [3]. The PSs-protein hybrids were tested *in vitro*, demonstrating excellent performances in PDT.

A similar approach was also applied to a wide range of insoluble materials, spanning from carbon-nanostructures, to different molecules of imaging/therapeutic interest, allowing their exploitation in anticancer and antimicrobial therapies.

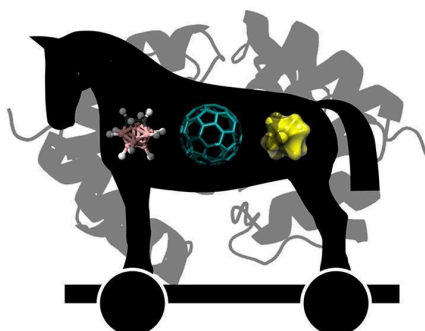

**Figure 1:** The Trojan Horse approach: proteins as supramolecular agents for delivery of hydrophobic molecules/nanoparticles.

[1] Cantelli A, Malferrari A, Soldà A et al. *JACS Au* (2021), 1(7):935

[2] Di Giosia M, Zerbetto F, Calvaresi M. *Acc. Mater. Res.* (2021);2(8):594

[3] Mattioli EJ, Ulfo L, Marconi A, et al. *Biomolecules.* (2023); 13(1):68

## Regenerative approaches for pomegranate waste: bioactive hybrid nanomaterials for oxidative stress treatment

Sebastiano Marra<sup>a</sup>, Virginia Venezia<sup>b</sup>, Elena Coccia<sup>c</sup>, Brigida Silvestri<sup>a</sup>, Roberta Imperatore<sup>c</sup>, Marina Paolucci<sup>c</sup>, Giuseppina Luciani<sup>b</sup>, Aniello Costantini<sup>b</sup>

<sup>a</sup>Dept. of Civil, Architectural and Environmental Engineering, University of Naples Federico II, Italy.

<sup>b</sup>Dept. of Chemical, Materials and Production Engineering, University of Naples Federico II, Italy.

<sup>c</sup>Dept. of Science and Technologies, University of Sannio, Italy.

E-mail: [sebastiano.marra@unina.it](mailto:sebastiano.marra@unina.it)

Pomegranate peels are an easily accessible source of chemical, physical, and biological wealth within biological wastes (BWs), that can be converted into a variety of functional products and novel materials with valuable multiple properties, such as antimicrobial and antioxidant properties [1]. Nevertheless, valuable substances, like neat polyphenols from pomegranate waste, are susceptible to environmental elements like heat and light, which causes loss of bioactivity as a result of degradation processes. Additionally, they are cytotoxic in high dosages. These restrictions can be solved by combining the organic phase with an inorganic component using an in-situ or ex-situ technique, which can even enhance the organic phase's inherent properties. SiO<sub>2</sub> has been recognised as a flexible and biocompatible platform for the design of hybrid nanomaterials because of its high purity, tuneable porosity, surface chemistry, and low cytotoxicity [2]. The aim of this work was to design pomegranate silica nanoparticles and to investigate their physicochemical, antioxidant and cytotoxic properties. The hybrid nanoparticles were obtained by wet chemical approaches, following an extra-situ strategy in which pomegranate extract was adsorbed on mesoporous silica nanoparticles. The hybrid nanostructures showed very promising antioxidant performance and were found, through cell viability assay and cell uptake analysis carried out on L929 mouse fibroblast cellular line, to be not cytotoxic at healthy and stress oxidative conditions (Figure 1).

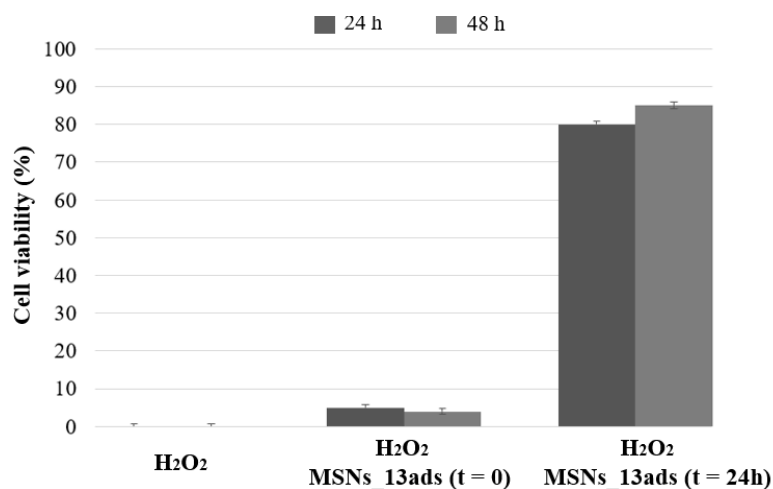

**Figure 1:** Cell viability at oxidative stress condition.

[1] M. Cano-Lamadrid, Francisco Artés-Hernández, *Foods*, 11(17), p. 2596.

[2] Venezia, V. et al., *Chemosphere*, 287, (2022), p. 131985.

## Metabolites from lichens against cholangiocarcinoma: from computational predictions to patient-derived organoids

Valeria Cavalloro,<sup>a</sup> Alessio Malacrida,<sup>b</sup> Mariarosaria Miloso,<sup>b</sup> Davide Ronchi,<sup>c</sup> Alice Fossati,<sup>a</sup> Cristian Turato,<sup>d</sup> Emanuela Martino,<sup>a</sup> and Simona Collina<sup>e</sup>

<sup>a</sup> Department of Earth and Environmental Sciences, University of Pavia Via Ferrata 1, 27100 Pavia, Italy

<sup>b</sup> School of Medicine and Surgery, University of Milan-Bicocca, 20900 Monza, Italy

<sup>c</sup> Department of Electrical, Computer and Biomedical Engineering. Via A. Ferrata, 5, 27100 Pavia, Italy

<sup>d</sup> Department of Molecular Medicine, University of Pavia Via Forlanini 6, 27100 Pavia, Italy

<sup>e</sup> Department of Drug Sciences, University of Pavia, Via Taramelli, 12, 27100 Pavia, Italy

E-mail: [valeria.cavalloro@unipv.it](mailto:valeria.cavalloro@unipv.it)

Cholangiocarcinoma (CC) is one of the most aggressive forms of cancer [1]. Conventional 2D cell lines may not accurately represent CC biology, thus hindering the identification of new active ingredients. To overcome this problem and better mimic the complexity of this pathology, models such as organoids have been developed as a representative 3D platform [2].

Over the years, lichens emerged as an interesting source of anticancer agents [3]. In this work, the fingerprints of two lichens belonging to genus *Cladonia*, *C. foliacea* and *C. rangiformis*, were drawn and the most abundant metabolites were identified. Next, the drug-like potential of the identified metabolites was evaluated via computational methods. Results obtained using SwissADME software highlighted that (S)-usnic acid (UA) was outstanding for its lead-like properties, due to its better solubility and possibility to obtain semisynthetic derivatives and extraction yield. Once identified UA as the best candidate, we assessed its potential as a ligand of already known anti-cancer targets. STITCH, STRING, and Cytoscape were queried and allowed the identification of MAPK1 and EIF4EBP1, both involved in the mTOR pathway, as potential targets of the selected metabolite.

Prompted by these promising results, we set up a new and sustainable protocol to isolate UA from *C. foliacea* and evaluated its effect on a CC 2D cell line (EGI-1 cell line), as well as on 3D organoid cultures (organoids from patients).

Results obtained from 2D and 3D models confirm the involvement of mTOR pathway and highlighted the high potential of UA in fighting CC. Moreover, ATP-based assay highlighted that UA was able to decrease organoid viability after 72h, data further confirmed by monitoring organoid volume trajectories.

[1] M. Kuwatani and N. Sakam, *Cancers* 15(14) (2023) 3686

[2] F. Schaub, U. Kim, C. Grandori, and A. Zarrinpar, *HPB* 22(1) (2020) S26-S27

[3] V. Cavalloro, G. Marrubini, R. Stabile, D. Rossi, P. Linciano, G. Gheza, S. Assini, E. Martino, and S. Collina *Molecules* 26 (2021) 455.

## Synthesis of natural phloroglucinol dimers and derivatives as potential antifungal agents

Francesca Sacchi, Francesca Annunziata, Francesca Saitta, Sharmila Gosh, Salvatore Princiotta, Andrea Pinto, Sabrina Dallavalle, Andrea Kunova, Paolo Cortesi, and Dimitrios Fessas

Department of Food, Environmental and Nutritional Sciences (DeFENS), Università degli Studi di Milano, Via Mangiagalli, 25, 20133, Milano

E-mail: francesca.sacchi@unimi.it

Phytopathogenic fungi affect the quality and the yield of produced crops, causing losses up to the 30% at all stages of crop production. To address the growing urgency in managing fungal diseases, there is the need to find novel compounds able to effectively inhibit plant pathogens, with low impact on human health and environment. In this context, the development of natural and nature-derived agrochemicals is a promising strategy.

In the last decades phlorotannins emerged as an important class of polyphenols. They get isolated from various brown seaweeds as very complex mixtures of phloroglucinol oligomers. In the present work, given the promising antifungal activity showed by the phlorotannin crude extracts [1], phloroglucinol dimers, namely diphenylethers (diphlorethol, and bifuhalol) and biphenyls (difucol), together with their partially or completely methylated/acetylated derivatives were synthesized (Figure 1). The potential antifungal activity of the pure compounds was investigated against *Pyricularia oryzae*, *Botrytis cinerea* and *Fusarium culmorum*. Furthermore, Differential Scanning Calorimetry (DSC) experiments were designed to study the potential interaction of the bioactives with a model phospholipid membrane representative of that of pathogenic fungi [2,3].

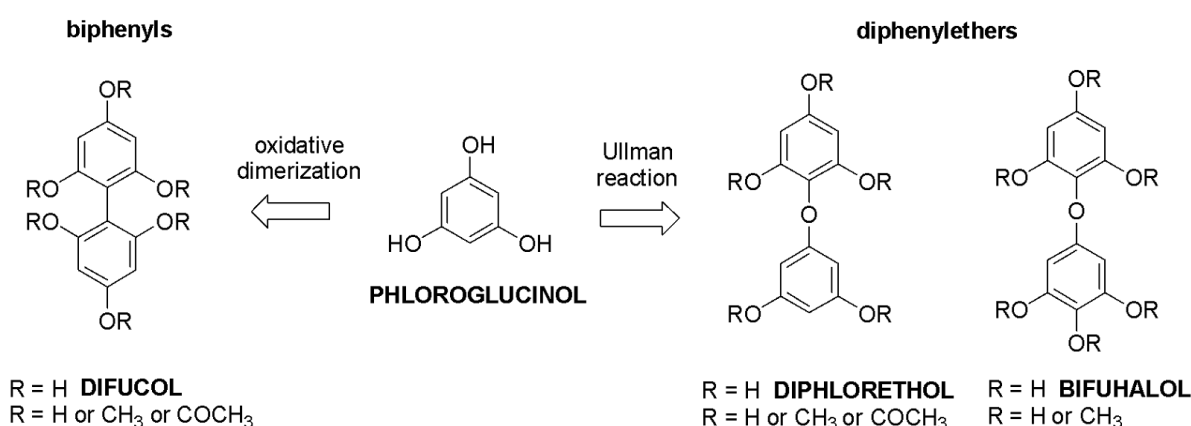

**Figure 1:** Structure of natural dimers difucol, diphlorethol, bifuhalol and derivatives.

[1] U. De Corato, R. Salimbeni, A. De Pretis, N. Avella, and G. Patrino, *Postharvest Biol. Technol.* 131 (2017) 16–30

[2] C. Wise, J. Falardeau, I. Hagberg, and T.J. Avis, *Phytopathology*, 104 (2014) 1036-1041

[3] F. Saitta, S. Mazzini, L. Mattio, M. Signorelli, S. Dallavalle, A. Pinto, and D. Fessas, *Food and Function*, 12 (2021) 12490-12502

## Harnessing biomasses from agri-food waste

Giulia Marcolli,<sup>a,b</sup> Silvia D'Alesio,<sup>a</sup> Maria Erica Di Pietro,<sup>a</sup> Giulia Leni,<sup>c</sup> Andrea Bassani,<sup>c</sup> and Arianna Rossetti<sup>a,b</sup>

<sup>a</sup> Department of Chemistry, Materials and Chemical Engineering "Giulio Natta", Politecnico di Milano, Via Mancinelli 7, 20131 Milan, Italy

<sup>b</sup> National Interuniversity Consortium of Materials Science and Technology (INSTM), Florence, Italy

<sup>c</sup> Department for Sustainable Food Process, Università Cattolica del Sacro Cuore, Via Emilia Parmense 84, 29122 Piacenza, Italy

E-mail: [giulia.marcolli@polimi.it](mailto:giulia.marcolli@polimi.it)

In the last years, the most interesting sustainable products are compounds derived from agricultural biomasses or residues from food processing industries. Successful transformation of agricultural waste into advanced industrial products is possible only through scientific and technological innovations for a sustainable economy [1]. A classical approach starts from an efficient extraction of the bioproducts of interest from the waste, followed by different treatments for the manufacturing of new materials and their subsequent commercialization [2].

In this work, referring to previous literature [2,3], selective extraction methods for polyphenols and other natural antioxidants have been developed for their possible reuse as reducing agents in the synthesis of silver nanoparticles (AgNPs) from food by-products. With this aim, white grape pomace (WGP), blueberry (BB) and spent coffee grounds (SCG) were selected as starting biomasses and treated with different extraction solvents. To understand the metabolite profiling of each sample extracted, a preliminary chemical characterization with <sup>1</sup>H-NMR was carried out. Additionally, an evaluation of the extraction with green solvents was performed with different Deep Eutectic Solvents (DES) preparations. Total phenolic content (TPC) analyses and antioxidant activity assays on the extracts are performed in collaboration with Università Cattolica del Sacro Cuore in Piacenza. The best performing extracts are under evaluation as green reducing agent for AgNPs synthesis with potential applications in active packaging materials, due to their intrinsic antibacterial activity.

Funder: Project funded under the National Recovery and Resilience Plan (NRRP), Mission 4 Component 2 Investment 1.3 - Call for proposals No. 341 of 15 March 2022 of Italian Ministry of University and Research funded by the European Union – NextGenerationEU; Award Number: Project code PE00000003, Concession Decree No. 1550 of 11 October 2022 adopted by the Italian Ministry of University and Research, CUP D43C22003060001, Project title "ON Foods - Research and innovation network on food and nutrition Sustainability, Safety and Security – Working ON Foods"

[1] A. K. Mohanty, S. Vivekanandhan, J. M. Pin, and M. Misra, *Science* 362 (2018) 536-542.

[2] K. M. Soto, C. T. Quezada-Cervantes, M. Hernández-Iturriaga, G. Luna-Bárcenas, R. Vazquez-Duhalt, and S. Mendoza, *LWT - Food Sci. Technol.* 103 (2019) 293-300.

[3] A. K. Mittal, Y. Chisti, and U. C. Banerjee, *Biotechnol. Adv.* 31 (2013) 346-356.

## Valorization of tomato skins as a source of lycopene: green extractions using DES menthol-thymol, $\alpha$ -pinene and extra virgin olive oil

Lorenza Marinaccio,<sup>a</sup> Adriano Mollica,<sup>a</sup> Gokhan Zengin<sup>b</sup>, Onur Bender,<sup>c</sup> and Azzurra Stefanucci<sup>a</sup>

<sup>a</sup> Department of Pharmacy, "G. d'Annunzio" University of Chieti-Pescara, Via dei Vestini 31, 66100-Chieti, Italy

<sup>b</sup> Department of Biology, Selcuk University, 42130-Konya, Turkey

<sup>c</sup> Biotechnology Institute, Ankara University, 06135-Ankara, Turkey

E-mail: lorenza.marinaccio@unich.it

The high production of tomato sauces and pastes leads to huge amounts of waste, e.g., tomato skins. This work aimed to sustainably valorize tomato skins as a source of lycopene, a carotenoid known for its antioxidant activity.

The ultrasound-assisted extraction (UAE) was chosen as the extraction technique along with terpenes as extraction solvents, in particular,  $\alpha$ -pinene and the deep eutectic solvent (DES) menthol:thymol 1:1. The lycopene content was determined by HPLC-DAD and compared to a UAE performed with n-hexane. As shown in Table 1, lycopene yields were high in the  $\alpha$ -pinene and DES menthol-thymol extracts, even though were lower than the extraction with n-hexane. One of the main challenges in using deep eutectic solvents is the removal of the solvent after the extraction. One of the achievements of this work was the evaporation of the DES menthol-thymol (as such and as azeotrope) by a Vacuum Vortex Evaporator obtaining dried extracts [1]. This result opens new perspectives on the application of volatile DES for the extraction of lipophilic compounds.

The second aim of this work was the practical use of tomato skins for producing a lycopene enriched extra virgin olive oil (EVO oil). The enriched EVO oil (0.9 mg lycopene/g EVO oil) showed improved antioxidant activity, especially in the DPPH assay. The cytotoxicity of the enriched EVO oil was determined by the iCelligence cell proliferation assay on PNT1A normal prostate cell line proving to be safe at concentrations below 500  $\mu$ g/mL. The results are coherent to the iCelligence analysis [2].

UAE n- hexane	UAE $\alpha$ -pinene	UAE DES M:T	UAE DES M:T (azeotrope)
735.9 $\pm$ 8.8	468.1 $\pm$ 1.4	484.2 $\pm$ 2.4	358.7 $\pm$ 1.2

**Table 1:** Lycopene extraction yields are expressed as milligrams of lycopene per gram of dried extract (DE). The results are the media of three experiments  $\pm$  SD.

[1] L. Marinaccio, G. Zengin, O. Bender, A. Cichelli, E. Novellino, A. Stefanucci, A. Mollica *Food Chemistry Advances* 4 (2024) 100656

[2] L. Marinaccio, G. Zengin, O. Bender, R. Dogan, A. Atalay, D. Masci, F. Flamminii, A. Stefanucci, A. Mollica *Food Bioscience* 60 (2024) 104466

## Thiourea Oxidized Derivatives: The Unveiling Of Their Potentiality Through Solvent-less Techniques

Pietro Caboni<sup>1</sup>, Francesco Basoccu<sup>1</sup>, Shyamal Kanti Bera<sup>1</sup>, Andrea Porcheddu<sup>1</sup>

Dipartimento di Scienze Chimiche e Geologiche, Università degli Studi di Cagliari, Cittadella Universitaria, Monserrato, 09042, Cagliari, Italy

E-mail: [pietro.caboni@unica.it](mailto:pietro.caboni@unica.it)

Nitrogen-containing compounds are essential for creating active pharmaceutical ingredients. However, the processes involved in synthesizing these compounds are not environmentally friendly. They typically require high temperatures, long reaction times, harmful reagents, and large amounts of solvents for both purification and synthesis steps [1]. In recent years, mechanochemistry has emerged as a solvent-free technique that significantly contributes to sustainable processes. It utilizes the mechanical energy generated by the motion of balls inside a jar to drive reactions. Equipment such as ball mills and double screw extruders require grinding media like balls or metal screws to release particles from the reaction mixture. A cutting-edge technology in mechanochemistry is Resonance Acoustic Mixing (RAM), which promotes reactivity even without the use of grinding media [2]. The RAM is based on a vertical oscillation mechanism at a constant frequency (60 Hz) by varying the G factor (until 100 G). The instrument was used to study the reactivity of thiourea trioxide (TTO), an oxidized derivative of thiourea, which was later used to synthesize 2-aminobenzoxazoles. Unlike thiourea dioxide (TDO), TTO is not available commercially, does not have reducing properties, and its degradation does not form dithionite. The 2-aminobenzoxazoles are synthesized using a liquid-assisted grinding method with water and are collected in good yield by recovering the reaction mixture with ethyl acetate, followed by easy filtration.



**Figure 1.** Resonance Acoustic Mixing used for 2-aminobenzoxazoles synthesis

[1] V. Šlachtová, J. Chasák, L. Brulíková, *ACS Omega* 4 (2019) 19314-19323

[2] A.A.L. Michalchuk, K.S. Hope, S. R. Kennedy, M. V. Blanco, E.V. Boldyreva, C.R. Pulham, *Chemical Communications* 54 (2018) 4033-4036

## Plasma-driven electrochemical direct synthesis of ammonia from nitrogen and water

Lavanya Veerapuram, Marco Francesco Torre, Francesco Tavella, Siglinda Perathoner, Gabriele Centi, Claudio Ampelli, and Chiara Genovese

Department of Chemical, Biological, Pharmaceutical and Environmental Sciences (ChiBioFarAm) – University of Messina, ERIC aisbl and CASPE/INSTM, V.le F. Stagno d'Alcontres, 31 – 98166 Messina, Italy

E-mail: [lavanya.veerapuram@studenti.unime.it](mailto:lavanya.veerapuram@studenti.unime.it).

Ammonia ( $\text{NH}_3$ ) plays a crucial role in the process industry, particularly in the production of nitrogen-based fertilizers and pharmaceuticals. However, the current industrial Haber–Bosch process is capital- and energy-intensive, with high  $\text{CO}_2$  emissions [1]. In this context, a combined catalyst-free plasma-electrolytic system was recently reported as a highly promising alternative to enhance the efficiency of the ammonia synthesis process [2, 3].

We report here the use of a novel aqueous electrochemical device with a micro plasma cathode for the direct production of ammonia under ambient conditions. The ammonia synthesis was driven by the generation of solvated electrons, produced through the contact of the micro plasma jet with the aqueous solution, acting as strong reducing agents without the necessity of additional reagents. This method overcomes the limitations of conventional catalytic systems in terms of activity and catalyst durability. For the first time, we report the optimization of the properties of plasma jet by controlling the plasma-liquid surface gap, flowrate, cell potential and current, thus improving overall efficiency. Preliminary experiments show a Faradaic efficiency to  $\text{NH}_3$  of more than 30% after 90 minutes of reaction. Further investigation is needed, but the results obtained are very promising for a sustainable method of  $\text{N}_2$  fixation.

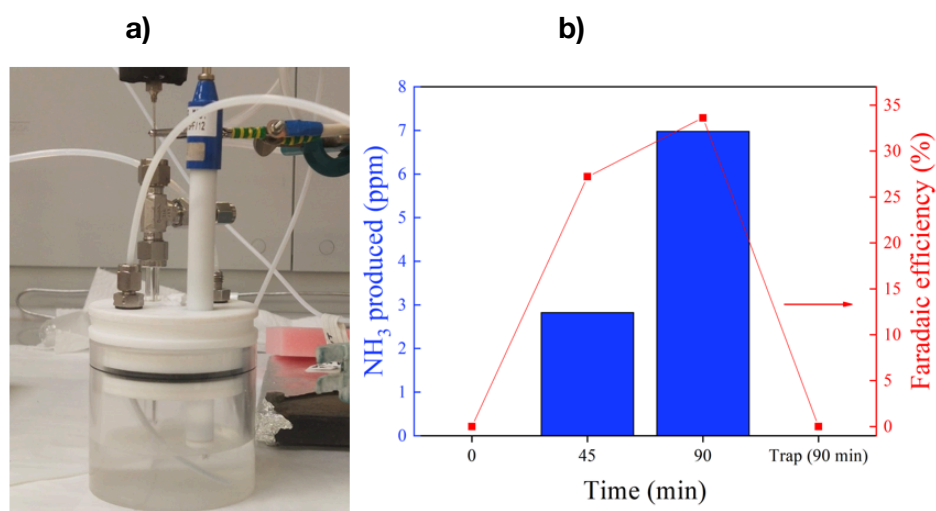

**Figure 1:** a) Plasma-Liquid electrochemical cell and b) yield to ammonia (ppm) and corresponding Faradaic efficiency (%) at 2 mA after 45 and 90 minutes.

[1] F. Tavella, D. Giusi, C. Ampelli, *Curr. Opin. Green Sustainable Chem.* 35 (2022) 100604

[2] Z. Huang, A. Xiao, D. Liu, X. Lu, K. Ostrikov, *Plasma Process Polym.* 19 (2022) e2100198

[3] Y. Gorbanev, E. Vervloessem, A. Nikiforov, A. Bogaerts, *ACS Sustainable Chem. Eng.* 8 7 (2020) 2996–3004

**Life cycle assessment of a landfill leachate treatment plant**

Federico Bedogni,<sup>a</sup> Francesco Arfelli,<sup>a</sup> Massimo Facchini,<sup>b</sup> and Fabrizio Passarini<sup>a,c</sup>

<sup>a</sup> *Department of Industrial Chemistry “Toso Montanari”, Alma Mater Studiorum - University of Bologna, via Piero Gobetti 85, 40129 Bologna, Italy*

<sup>b</sup> *Herambiente S.p.A., Business Unit Rifiuti Industriali, Viale C. Berti Pichat 2/4 40127 Bologna, Italy*

<sup>c</sup> *Interdepartmental Centre for Industrial Research “Renewable Sources, Environment, Blue Growth, Energy”, Alma Mater Studiorum - University of Bologna, 47921 Rimini, Italy*

*E-mail: federico.bedogni2@unibo.it*

The landfill remains one of the most frequent final destinations for the end-of-life of waste today at the national level (20% of MSW and 51% of industrial waste) [1]. A comprehensive examination of a full-scale facility that treats landfill leachate was conducted. The plant is composed of a chemical-physical treatment and a biological treatment designed for the abatement of nitrogen (90.3%), COD (92.2%) and SS (95.1%), heavy metals and other pollutants. The precipitated sludges are centrifuged and sent to landfill. The study of the environmental impacts has been performed by applying the principles of the Life Cycle Assessment (LCA) techniques using ReCiPe 2016 [2] as the assessment method. 1m<sup>3</sup> of leachate entering the plant is used as a functional unit (FU). Twelve impact categories have been analysed including in the system boundaries of the study the production and transport of the chemical used in the process, the electricity production and distribution, maintenance of the plant, sludge disposal and the law-compliant discharge of the clarified residues into seawater (including PFAS) [3]. The results show that the permanence of the centrifugated sludge in landfill is by far the most impacting phase of the system regarding the global warming potential (GWP), the toxicity and the ecotoxicity, representing the most harmful parameter of the entire study. The next advancements will concern a focus on the PFAS removal efficiency of the plant and a life cycle assessment (LCA) including this removal in the functional unit (FU).

[1] ISPRA: Catasto Nazionale Rifiuti, anno 2022,

<https://www.catasto-rifiuti.isprambiente.it/index.php?pg=gestnazione&advice=si>

[2] Huijbregts, M.A.J., Steinmann, Z.J.N., Elshout, P.M.F. et al. ReCiPe2016: a harmonised life cycle impact assessment method at midpoint and endpoint level. *Int J Life Cycle Assess* 22, 138–147 (2017).

<https://doi.org/10.1007/s11367-016-1246-y>.

[3] H. Holmquist, P. Fantke, I. T. Cousins, M. Owsianiak, I. Liagkouridis, and G. M. Peters, An (Eco)Toxicity Life Cycle Impact Assessment Framework for Per- And Polyfluoroalkyl Substances, *Environmental Science & Technology* 2020 54 (10), 6224-6234.

## **Evaluating the environmental impact of methane-to-hydrogen catalytic processes: a life cycle assessment**

**Eleonora Rossi,<sup>a,b</sup> Zeynep Unal,<sup>a</sup> Lisa Canuti,<sup>a</sup> Luca Ciacci,<sup>a,b</sup> Ilenia Giarnieri,<sup>a</sup> Lole Jurado,<sup>c</sup> Miguel Angel Centeno,<sup>c</sup> David Martín Moya,<sup>d</sup> Antonio Monzón,<sup>d</sup> Patricia Benito,<sup>a</sup> and Fabrizio Passarini<sup>a,b</sup>**

<sup>a</sup> *Department of Industrial Chemistry "Toso Montanari", University of Bologna, via Gobetti, 85, 40129 Bologna, Italy*

<sup>b</sup> *Interdepartmental Centre of Industrial Research "Renewable Resources, Environment, Sea and Energy", University of Bologna, Via Dario Campana, 71, 47922 Rimini, Italy.*

<sup>c</sup> *Centro de Investigaciones Científicas Isla de la Cartuja: University of Seville, C. Américo Vespucio, 49, 41092 Sevilla, Spain*

<sup>d</sup> *Instituto de Nanociencia y Materiales de Aragón, University of Zaragoza, Campus Río Ebro, 50018 Zaragoza, Spain*

*E-mail: [eleonora.rossi51@unibo.it](mailto:eleonora.rossi51@unibo.it)*

The rising cost and decreasing supply of fossil fuels have driven the search for clean, alternative energy sources. Hydrogen is a promising clean fuel, but current production methods often generate significant CO<sub>2</sub> emissions [1]. The STORMING project, funded by the European Union's Horizon Europe program, aims to address this challenge by developing a novel catalytic technology that converts methane gas (CH<sub>4</sub>) into two valuable products: clean-burning hydrogen fuel (H<sub>2</sub>) and carbon nanotubes for batteries. Three universities, within the project consortium, are developing catalysts for this purpose: the University of Bologna using the coprecipitation method, the University of Zaragoza employing the citrate method, and the University of Seville utilizing mechanochemistry.

A life cycle assessment (LCA) [2] is conducted to evaluate the environmental impact of these processes. The LCA methodology involves a comprehensive evaluation of the catalyst's entire life cycle, including both the production impacts and the productivity of the catalysts. This environmental assessment identifies hotspots and conducts an initial screening of the technologies to determine their relative environmental impacts. Additionally, two different pretreatment methods, with and without preliminary catalyst reduction, are compared to assess their respective impacts.

The main results of the study indicate that the energy consumption of the mechanochemistry method is a critical concern. However, it is reasonable to assume that the scaled-up process will be more energy-efficient than the laboratory-scale version. Furthermore, when comparing reductive and non-reductive production methods, reductive catalysts show negligible efficiency gains but are associated with slightly higher environmental impacts.

[1] Atilhan, Selma, et al. "Green hydrogen as an alternative fuel for the shipping industry." *Current Opinion in Chemical Engineering* 31 (2021): 100668.

[2] Curran, Mary Ann. "Life cycle assessment: a review of the methodology and its application to sustainability." *Current Opinion in Chemical Engineering* 2.3 (2013): 273-277.

## ZnO – based Molecular Imprinted Polymers in pesticides detection: a novel, greener approach

Lorenzo Casoli<sup>a</sup>, Elvira Maria Bauer<sup>b</sup>, Lorenzo Gontrani<sup>a</sup>, Cosimo Ricci<sup>a</sup>, Giorgia Ciufolini<sup>a</sup>,  
Marilena Carbone<sup>a</sup>

<sup>a</sup> *STARTNETICS - Department of Chemical Science and Technologies, University of Rome Tor Vergata, Via della Ricerca Scientifica, 00133, Rome*

<sup>b</sup> *Institute of Structure of Matter, Italian National Research Council (ISM-CNR) Via Salaria km 29.3, 00015, Monterotondo*

E-mail: [lorenzo.casoli@uniroma2.it](mailto:lorenzo.casoli@uniroma2.it)

The widespread use of triazole pesticides is important for protecting crops, herbs and spices due to their efficacy against fungal diseases. However, these pesticides pose significant health risks, particularly penconazole, which is severely toxic. Maximum residue levels for penconazole in food have been set by regulatory authorities [1]. Conventional detection methods, such as high-performance liquid chromatography, are effective but costly, time-consuming and not eco friendly. This study presents a novel, more environmentally friendly detection approach through the combination of fluorescence methods with molecular imprinted polymers (MIPs). Specifically, a penconazole-selective MIP with a zinc oxide (ZnO) nanoparticle (NP) core is developed. The ZnO NP surface is modified with (3-aminopropyl) triethoxysilane (APTES), which allows detection through changes in fluorescence intensity upon interaction of the chlorine of penconazole with the amino group of APTES [2]. MIPs, with their high selectivity and reduced time requirements, offer a promising alternative to traditional food analysis methods. In this study, the MIP is prepared with two silanes: tetraorthosilicate (TEOS) as crosslinker and APTES as monomer. The polymerisation takes place around the ZnO NPs and the surface is modified to interact with penconazole, which serves both as analyte and template and is removed at the end to leave a porous MIP with a fluorescent core. ZnO is chosen as the fluorophore for its safety, biocompatibility, straightforward preparation and adjustable properties [3]. In conclusion, this approach may provide a highly selective detection method and a more sustainable alternative to conventional techniques.

[1] Almeida, F., et al. *Biomolecules* 2019, 9(10), 521.

[2] Bauer E. M. et al. *Materials* 2022, 15(22), 8050

[3] Gontrani, L. et al. *Int. J. Mol. Sci.* 2024, 25(5), 2703

**Preparation, characterization, and applications of 4H-SiC porous flakes via the ECE process**

Vanessa Spanò,<sup>a</sup> Matteo Barcellona,<sup>a,b</sup> Maria Elena Fragalà,<sup>a,b</sup> Salvatore Scirè,<sup>a</sup> Roberto Fiorenza,<sup>a</sup> Gaël Gautier,<sup>c</sup> and Thomas Defforge<sup>c</sup>

<sup>a</sup> *Dipartimento di Scienze Chimiche, Università degli studi di Catania, Viale Andrea Doria 6, 95125, Italia*

<sup>b</sup> *INSTM Udr Catania – Catania, 95125, Italia*

<sup>c</sup> *GREMAN UMR-CNRS 7347, INSA Centre Val de Loire, Université de Tours, Tours, France*

E-mail: [vanessa.spano@phd.unict.it](mailto:vanessa.spano@phd.unict.it)

Water resources are contaminated by agriculture, factories, and other human activities that release several chemical compounds, including pesticides, dyes, and pharmaceuticals. Traditional water treatment methods are not able to remove these contaminants and it is fundamental to find new methodologies for water remediation [1]. The AOP processes, and particularly the heterogeneous photocatalysis, can be employed to solve the problem [2]. Therefore, to reduce environmental pollution is also necessary to find an alternative to fossil fuels. The green hydrogen, produced by artificial photosynthesis with a photocatalyst, can be employed as the future energy vector [3].

The study investigates the potential applications of silicon carbide (SiC), i.e. 4H-SiC, in the fields of water remediation and the generation of green hydrogen via photocatalytic approaches. In this case, the novelty is employing porous flakes of 4H-SiC obtained via Electrochemical Etching (ECE) of 4H-SiC wafers with fluoridric acid (HF) and pulsed current, on both wafer faces.

4H-SiC porous flakes have been characterized by Scanning Electron Microscopy (SEM) and Brunauer-Emmett-Teller (BET) to establish their morphology and porosity. Different morphological characteristics were found for Si-face and C-face flakes of two different batches. They also exhibit differences in porosity and corresponding surface areas.

Due to the porosity of the samples, pollutants from water, i.e. Methylene Blue (MB), can be captured via the adsorption process and will be degraded through the photocatalytic process with a UV lamp. Firstly, the thermodynamic adsorption mechanism of the dye is investigated to determine the adsorption capacity of the samples. Finally, it is possible to study the photocatalytic properties of the different 4H-SiC porous flakes. For a total of 5 hours of illumination with a UV lamp, the ethanol photo-reforming process has been performed to produce green hydrogen. The amount of hydrogen generated from the process has been quantified via Gas Chromatography (GC) measurement.

[1] S.S. Naik, S.J. Lee, J. Theerthagiri, Y. Yu, and M.Y. Choi, *J. Hazard. Mater.* 418 (2021) 126269

[2] M. Cheng, G. Zeng, D. Huang, C. Lai, P. Xu, C. Zhang, Y. Liu, *J. Chem. Eng. J* 284 (2016) 582-598

[3] G.W. Crabtree, M.S. Dresselhaus, M. V. Buchanan, *Phys Today* 57 (2004) 39–44

## **Removal of CECs through pilot-scale Raceway Pond Reactor from municipal WWTP effluents by iron biochar assisted solar photo-Fenton processes**

Antonio Faggiano<sup>a</sup>, Paula Soriano Molina<sup>b</sup>, Oriana Motta,<sup>c</sup> Maria Riccardi,<sup>a</sup> Antonino Fiorentino<sup>d</sup>, Antonio Proto<sup>a</sup>

<sup>a</sup>*Department of Chemistry and Biology “Adolfo Zambelli”, University of Salerno, via Giovanni Paolo II 132, 84084 Fisciano, SA, Italy*

<sup>b</sup>*Solar Energy Research Centre (CIESOL), Joint Centre University of Almeria-CIEMAT, Ctra. de Sacramento s/n, Almería 04120, Spain*

<sup>c</sup>*Department of Medicine Surgery and Dentistry “Scuola Medica Salernitana”, University of Salerno, via S. Allende 1, 84081 Baronissi, SA, Italy*

<sup>d</sup>*Department of Chemistry, University of Milan, Via Golgi 19, MI, Italy*

E-mail: [anfaggiano@unisa.it](mailto:anfaggiano@unisa.it)

The global water scarcity crisis necessitates effective wastewater reuse through advanced disinfection and decontamination methods. Municipal wastewater treatment plants must upgrade to address organic micropollutants, which pose significant public health risks. Emerging contaminants (CECs) such as pharmaceuticals and pesticides are particularly concerning due to their toxic properties [1]. Consequently, tertiary treatments that comply with environmental regulations are urgently needed. Advanced oxidation processes (AOPs), especially the solar photo-Fenton (SPF) process, are promising for degrading micropollutants via hydroxyl radicals ( $\cdot\text{OH}$ ) generated by iron ions,  $\text{H}_2\text{O}_2$  and UV-visible radiation [2]. Biochar (BC), derived from biomass pyrolysis, is ideal for adsorption and catalysis due to its high surface area and porous structure. When functionalized with iron (FeBC), BC's catalytic properties are enhanced, providing an efficient and sustainable solution for wastewater treatment at neutral pH [3]. This research evaluates a novel SPF process using FeBC to remove the CEC acetamiprid (ACTM) from secondary municipal wastewater. The catalytic performance of FeBC was assessed in both batch and continuous flow modes within a pilot-scale raceway pond reactor (RPR). The study optimized parameters such as catalyst loading and  $\text{H}_2\text{O}_2$  concentration to maximize ACTM degradation. Both adsorption and oxidation efficiencies were evaluated, comparing FeBC with raw BC (RBC). The results show that FeBC in the RPR setup can degrade up to 99% of acetamiprid from secondary effluent. This method offers a highly effective and sustainable solution for treating wastewater containing CECs, enhancing reclaimed water quality, and meeting stringent environmental regulations. This novel application aligns with global sustainability goals and presents a promising path for sustainable water management, particularly in agricultural irrigation.

[1] E. Gualda-Alonso, P. Soriano-Molina, J.L. Casas López, J.L. García Sánchez, P. Plaza-Bolaños, A. Agüera, J.A. Sánchez Pérez, *App. Cat. B* 2022, 319, 121908.

[2] A. Fiorentino, P. Soriano-Molina, M. J. Abeledo-Lameiro, I. de la Obra, A. Proto, M. I. Polo-López, J. A. Sánchez Pérez, L. Rizzo, *J. Environ. Chem. Eng.* 2022, 10, 108777.

## Reactivity comparison of Granite scraps and Red Mud towards CO<sub>2</sub> in mechanochemical processes

Costantino Cau,<sup>a,b</sup> Fabrizio Murgia,<sup>b,c</sup> Maria Domenica Simula,<sup>b</sup> Paola Mameli,<sup>b</sup> Sebastiano Garroni,<sup>b,c</sup> Stefano Enzo,<sup>b</sup> and Gabriele Mulas<sup>b,c</sup>

<sup>a</sup> Department of Architecture, design and urban planning, Università degli studi di Sassari, Palazzo del Pou Salit-Piazza Duomo 6, 07041 Alghero

<sup>b</sup> Department of Chemical, Physical, Mathematical and Natural Sciences, Università degli studi di Sassari, Via Vienna 2, 07100 Sassari

<sup>c</sup> INSTM (Consorzio Interuniversitario Nazionale per la Scienza e la Tecnologia dei Materiali)

E-mail:c.cau1@phd.uniss.it

The unceasing exploitation of fossil fuels during the last century actively contributed to the increase of the natural greenhouse effect [1] which, negatively affects the biosphere. In this scenario a wide array of strategies aimed at reducing the content of anthropic CO<sub>2</sub> by sequestration or reuse in industrial processes, are gaining a pivotal role, and are encompassed in the Carbon Capture, Utilisation and Storage (CCUS) policies. There are several well-known natural processes that tends to convert CO<sub>2</sub> into carbonate minerals, such as the serpentinization reactions, which, in addition to CO<sub>2</sub> sequestration, also produce hydrogen and methane [2]. Moreover, the possibility to use granite waste (GW) and red mud (RM) for these valuable processes could represent a smart strategy to get rid of serious threats for the environment [3]. In accordance with this background, this work focuses on the reactivity of GW and RM towards carbon dioxide to promote its sequestration and further production of valuable chemicals.

The mechanochemical activated reactions of these wastes was studied together with the reactions kinetic highlighting that GW are capable of adsorbing 16 μmol·min<sup>-1</sup> of CO<sub>2</sub>, producing a 10% (v/v) of hydrogen and more than 350 ppm of methane.

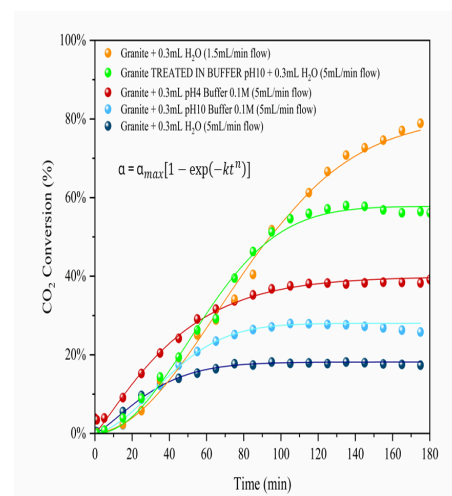

**Figure 1:** Kinetic profile of the mechanochemical activated reactions

[1] M. M. Rahman, and K. Alam, *Renew. Energy* 195 (2022) 203–213

[2] N. G. Holm, C. Oze, O. Mousis, J. H. Waite, and A. Guilbert-Lepoutre, *Astrobiology* 15 (2015) 587–600

[3] A. Russkikh, G. Shterk, B. H. Al-Solami, B. A. Fadhel, A. Ramirez, and J. Gascon, *ChemSusChem* 13

## Design, synthesis, and biological evaluation of new ligands as potential therapeutic agents for persistent pain treatment

Giuliana Costanzo, Giuseppe Cosentino, Vincenzo Patamia,  
Agostino Marrazzo, Carmela Parenti, Emanuele Amata,  
Antonio Rescifina, and Lorella Pasquinucci

*Dipartimento di Scienze del Farmaco e della Salute,  
Università degli Studi di Catania, Via S. Sofia 64, 95125-Catania, Italia*

*E-mail: [giuliana.costanzo1@unict.it](mailto:giuliana.costanzo1@unict.it)*

Simultaneous targeting of different opioid receptors is a more effective and safe therapeutic strategy than conventional opioid receptor therapies. Moreover, sigma-1 receptor ( $\sigma_1R$ ) antagonism is an opioid adjuvant strategy. In medicinal chemistry, *N*-normetazocine has been investigated to develop new drugs. The *N*-normetazocine-based LP1 and LP2 compounds showed an interesting *in vivo* profile acting as dual-target mu-opioid receptor (MOR)/delta-opioid receptor (DOR) ligands.

Thus, LP1 and LP2 analogs were developed to obtain new opioid ligands with improved pharmacological profiles. These small molecules were obtained through *N*-substituent modifications, and the most promising compounds were evaluated *in vivo* in different pain animal models, which showed dose-dependent analgesic effects (Figure 1) [1]. Moreover, to investigate the pivotal role of *N*-normetazocine stereochemistry, we also synthesized the destro-isomer of LP2 derivatives that displayed a nanomolar affinity for  $\sigma_1R$ . The  $\sigma_1R$  selective compound (+)-2*R/S*-LP2 decreased the second phase of the formalin test, showing an antagonist  $\sigma_1R$  profile. It also significantly inhibited mechanical allodynia in CCI rats [2]. Overall, these results define a set of chemical modifications that allow affinity modulation towards opioid and sigma receptors.

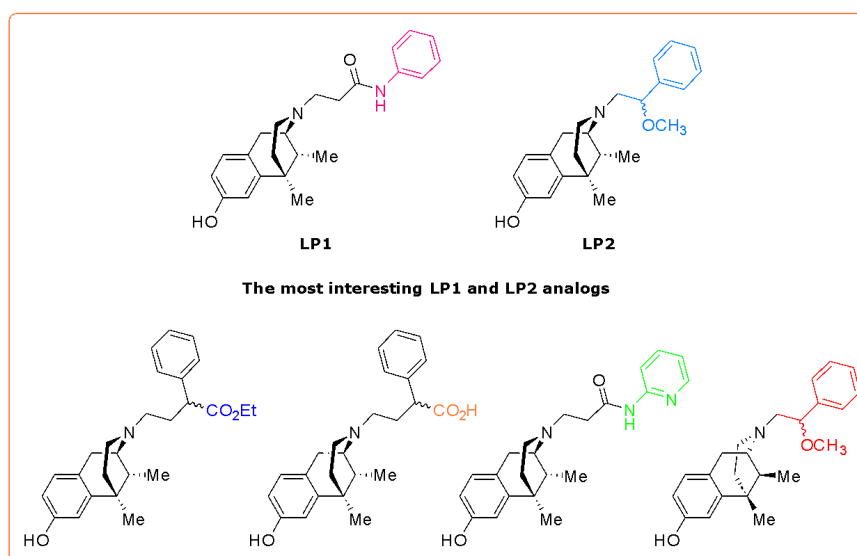

**Figure 1:** Development of novel LP1 and LP2 analogs.

[1] G. Costanzo, R. Turnaturi, C. Parenti, S. Spoto, S. Piana, M. Dichiarà, C. Zagni, A. R. Galambos, N. Essmat, A. Marrazzo, E. Amata, M. Al-Khrasani, and L. Pasquinucci, *Molecules* 28 (2023) 4827.

[2] S. Denaro, L. Pasquinucci, R. Turnaturi, C. Alberghina, et al. *Mol. Neurobiol.* 61 (2023) 2672–2685.

---

## OR065

### Castagnoli-Cushman reaction(CCR)-mediated synthesis of preferential HDAC6 inhibitors as modulators of idiopathic pulmonary fibrosis (IPF)-related fibrosis

Anna Fontana<sup>a,b</sup>

<sup>a</sup> Department of Biotechnology, Chemistry and Pharmacy, University of Siena, Via A. Moro, 2, 53100-Siena, Italy

Current affiliation: <sup>b</sup> Department of Drug Sciences, University of Pavia, Viale Taramelli 12, 27100-Pavia, Italy

E-mail: a.fontana5@student.unisi.it; anna.fontana03@universitadipavia.it

IPF is a chronic, progressive, and fibrotic interstitial lung disease of unknown aetiology, and with an inauspicious prognosis. The lack of resolutive therapies and the paucity of reliable disease models have prioritized the need of innovative approach to investigate IPF pathogenesis aimed at validating new druggable targets. Among these, histone deacetylase 6 (HDAC6) has emerged as a common thread in the generation of the IPF phenotype, being involved in several profibrotic pathways. By resorting to small molecule, Campiani *et al.* proved the antifibrotic effect promoted by pharmacological HDAC6 inhibition in *ex vivo* IPF model [1]. In an attempt to disclose new chemical entities as potential modulators of the IPF-related fibrosis, we herein present a new series of preferential HDAC6 inhibitors (HDAC6is) **5a-o** based on spirotetrahydroisoquinoline (spiroTHIQ) scaffold. These analogues were prepared *via* the three-component CCR as the key step which allowed the straightforward installation of the spirocycle in the THIQ core. Consistent with the docking results, the enzymatic assay enabled the selection of four hit compounds endowed with a preferential HDAC6 inhibition over a selected panel of isoforms. To exclude off-target liability, the selective target engagement was evaluated for best candidates in living cells, by determining the acetylation levels of histone H3 and  $\alpha$ -tubulin, the peculiar non-histone substrate of HDAC6. The best hit **5n** was evaluated for its ability to attenuate the fibrotic event both in human IPF lung fibroblasts and cultured cells isolated from bronchoalveolar lavage fluid of IPF patients. Preliminary toxicity was interrogated in *ex vivo* (Langendorff-isolated rat hearts), and *in vivo* (zebrafish model) studies, displaying a good safety margin for **5n** which could be considered a promising pharmacological tool for IPF treatment.

[1] G. Campiani, C. Cavella, J.D. Osko, M. Brindisi, N. Relitti, S. Brogi, A.P. Saraswati, S. Federico, G. Chemi, S. Maramai, G. Carullo, B. Jaeger, A. Carleo, R. Benedetti, F. Sarno, S. Lamponi, P. Rottoli, E. Bargagli, C. Bertucci, D. Tedesco, D. Herp, J. Senger, G. Ruberti, F. Saccoccia, S.Saponara, B. Gorelli, M. Valoti, B. Kennedy, H. Sundaramurthi, S. Butini, M. Jung, K.M. Roach, L. Altucci, P. Bradding, D.W. Christianson, S. Gemma, and A. Prasse, *J. Med. Chem.* (2021), 64, 9960–9988.

## Discovery of the first-in-class pyrazole-oxazole based synergistic antifungal agent

Barone Simona,<sup>a</sup> Sveva Pelliccia,<sup>a</sup> Pasquale Russomanno,<sup>b</sup> Antonella Ilenia Alfano,<sup>a</sup> Martina Miranda,<sup>c</sup> Baptiste Mateu,<sup>a</sup> Lorena Coretti,<sup>a</sup> Francesca Lembo,<sup>a</sup> Aron Curtis,<sup>d</sup> Kevin Kavanagh,<sup>d</sup> Elisabetta Buommino,<sup>a</sup> and Margherita Brindisi<sup>a</sup>

<sup>a</sup> Department of Pharmacy (DoE 2023-2027), University of Naples Federico II, via D. Montesano 49, 80131, Naples, Italy

<sup>b</sup> CERM, University of Florence Via Sacconi, 6 50019 Sesto Fiorentino (FI), Italy

<sup>c</sup> Department of Pharmaceutical and Cell Biological Chemistry, Pharmaceutical Institute, University of Bonn, An der Immenburg 4, 53121 Bonn, Germany

<sup>d</sup> Department of Biology, Maynooth University, W23 F2H6 Maynooth, Co. Kildare, Ireland.

E-mail: [simona.barone2@unina.it](mailto:simona.barone2@unina.it)

*C. albicans* is among most common infective agents responsible for invasive fungal infections (IFIs) [1], representing an emerging healthcare issue related to high morbidity and mortality in immunocompromised patients. Azoles antifungals, the first-line treatment for both systemic and superficial mycoses, block the biosynthesis of ergosterol, a fungal-specific membrane sterol. Notably, triazole antifungals such as Voriconazole (VRC) are extensively used in the treatment of *C. albicans* infections for their efficacy in the inhibition of the lanosterol 14 $\alpha$ -demethylase (CYP51), encoded by the ERG11 gene, and involved in the conversion of lanosterol to ergosterol. Over the years, the abuse or misuse of azole drugs significantly induced the rise of azoles-resistant *C. albicans* strains [2], primarily driven by mutations in targeted gene ERG11. Thus, the emerging public health burden of IFIs requires the need to find new antifungal agents both effective in resistant strains or able to synergistically enhance the effect of existing antifungal drugs. Herein we report the discovery of first-in-class 1,4-pyrazole-isoxazole, namely **Cpd1**, showing synergistic activity with azole drugs. **Cpd1** was assessed in azole resistant *C. albicans* ATCC 10231 strain in combination with VRC. This combination was able to reduce the yeast-to-hypha transition, through the downregulation of ERG11 gene expression, as confirmed by qRT-PCR analysis. Also, Cpd1-VRC combination was assessed in an *in vivo* model of *Galleria mellonella* infection, showing enhanced survival rates, while no effects were detected for VOR administered alone, confirming the synergistic efficacy for **Cpd1** also in *in vivo* settings.

To further investigate the molecular basis of the synergistic efficacy of **Cpd1**, molecular docking studies were performed, unveiling the unique ability of Cpd1-VOR combination to completely occupy all lanosterol 14 $\alpha$ -demethylase binding sites. In conclusion, this study led to the identification of a novel class of synergistic antifungal agents, laying the basis for further development and advancement of this promising therapeutic class.

[1] W. Fang, J. Wu, M. Cheng, X. Zhu, M. Du, C. Chen, et al. *J. Biomed. Sci.* 30 (2023), 42

[2] S.G. Whaley, E.L. Berkow, J.M. Rybak, A.T. Nishimoto, K.S. Barker, P.D. Rogers, *Front. Microbiol.* 12 (2017) 7:2173.

## Design, synthesis and biophysical evaluation of covalent ligands targeting a bacterial lectin

Giulia Antonini,<sup>a</sup> Annabelle Varrot,<sup>b</sup> Anna Bernardi,<sup>a</sup> Laura Belvisi,<sup>a</sup> and Sarah Mazzotta<sup>a</sup>

<sup>a</sup> Dipartimento di Chimica, Università degli Studi di Milano, via Golgi 19, 20133-Milano, Italy

<sup>b</sup> Univ.Grenoble Alpes, CERMAV, CNRS, 38000 Grenoble, France

E-mail: [giulia.antonini@unimi.it](mailto:giulia.antonini@unimi.it)

The opportunistic Gram-negative pathogen *Burkholderia cenocepacia* is a globally spread, multidrug-resistant bacterium causing deadly lung infections in immunocompromised or cystic fibrosis patients. It uses lectins, carbohydrate-binding proteins, as virulence factors to adhere to host tissues by recognizing glycoconjugates on the host cells' surface. Among these lectins, BC2L-C has been proposed as a key player in the adhesion process. In particular, its N-terminal fucose-binding domain (BC2L-C-Nt) represents a promising target for designing new antimicrobials that may prevent lectin-mediated bacterial adhesion to the host cells [1]. We have recently reported a first generation of glycomimetic ligands targeting BC2L-C-Nt [1,2]. These compounds contain a fucose residue connected to fragments capable of engaging a secondary site in the lectin, near the fucose-binding region. This resulted in the first BC2L-C-Nt synthetic ligands showing up to a 10-fold affinity gain over the parent monosaccharide [2].

To improve affinity with the target lectin, a new generation of ligands was designed to covalently interact with Lys108 near the fucose binding region (Figure 1A).

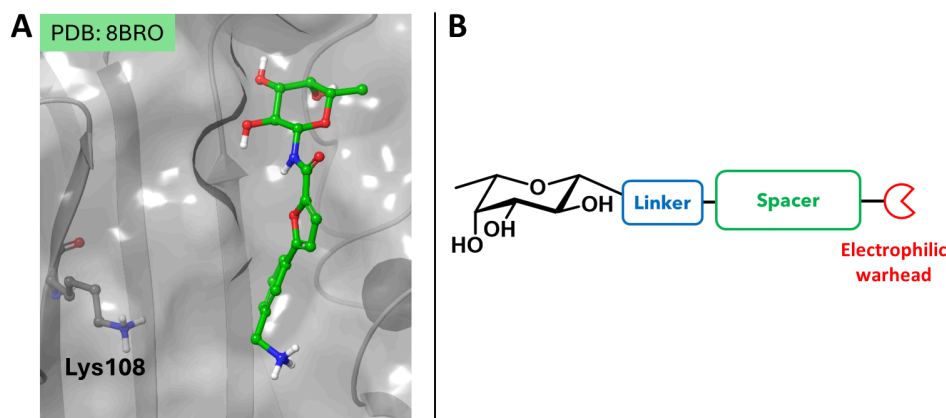

**Figure 1:** A) Lys108 in a crystal structure of BC2L-C-Nt (PDB ID 8BRO). B) Schematic representation of designed covalent ligands.

The designed compounds feature a fucose core linked through a spacer to an electrophilic group that may react with Lys108. The work validates a computational protocol for designing covalent lectin ligands and produces synthetically accessible monovalent fucosides that bind to BC2L-C-Nt as strongly as its minimal native oligosaccharide ligands, as verified through SPR and MS analyses.

[1] R. Bermeo, K. Lal, D. Ruggeri, D. Lanaro, S. Mazzotta, F. Vasile, A. Imberty, L. Belvisi, A. Bernardi and A. Varrot, *ACS Chemical Biology*, 2022, 17, 2899-2910.

[2] S. Mazzotta, G. Antonini, F. Vasile, E. Gillon, J. Lundstrøm, A. Varrot, L. Belvisi and A. Bernardi, *Molecules* 2023, 28, 1494.

**Development of an electrochemical biosensor for miRNA detection encapsulated in lipid nanoparticles**

Wanda Cimmino,<sup>a</sup> Alessia Angelillo,<sup>a</sup> Giuseppina Rea,<sup>a</sup> Valeria Nele,<sup>a</sup> Virginia Campani,<sup>b</sup> Giuseppe De Rosa,<sup>a</sup> and Stefano Cinti<sup>a</sup>

<sup>a</sup> *Department of pharmacy, University of Naples Federico II, Via Montesano 49, 80131-Napoli, Italy*

<sup>b</sup> *Department of Life Health Sciences and Health Professions, Link Campus University, Rome 00165, Italy*

Email: [wanda.cimmino@unina.it](mailto:wanda.cimmino@unina.it)

Lipid nanoparticles (LNPs) represent a versatile platform for the delivery of a wide range of nucleic acid-based therapies, including microRNAs (miRNAs). The ability of LNPs to encapsulate and protect miRNAs from degradation, as well as their ability to simultaneously promote targeted cellular uptake and controlled release, has made them increasingly used for miRNA-based therapies, i.e. COVID vaccination. Although pharmaceutical technologists are capable to encapsulate nucleic acids in various type of LNPs, the quantification of the encapsulated drug is essential to both assure the quality control and the subsequent efficacy of the therapy. Nowadays, classical analytical approaches such as fluorescence, UV-Vis spectrophotometry and chromatography, are the mainly utilized for the quantification of the encapsulated. However, the user-friendly and low-cost quantification of the efficacy of encapsulation within LNPs represents an important research focus, as it would allow the quantity of encapsulated miRNAs to be monitored allowing for immediate quality control. Recently, we demonstrated a novel sensor-based approach to quantify the encapsulation of model drug in liposomes [1]. To apply the preliminary results to a more specific context, in this work we present the customization of an electrochemical strip to quantify the encapsulation of miRNAs, i.e., miRNA-218 associated to triple negative breast cancer, within LNPs. We provide a rapid and sensitive method to assess the concentrations of miRNAs actually encapsulated obtaining a satisfactory agreement in comparison with the spectrophotometric traditional approach. In particular, the platform is based on a commercial screen-printed gold electrode modified with a DNA-probe that has been designed to be fully complementary to the target miRNA-218. The electrochemical system has been successfully combined with a 3D-printed chamber that allowed the use of multi-electrodes at the same time also using Triton X-100 as the solvent to open the LNPs and to release the encapsulated miRNA-218 with a detection limit down to ca. 1 of nM.

[1] S. Romanò, A. Angelillo, W. Cimmino, N. Iaccarino, V. Nele, V. Campani, G. De Rosa, and S. Cinti, *Anal. Chem.* 96 (2024) 11651-11656

## **3D-printed electrochemical sensing device for on-field testing applications**

Panagiota Kalligosfyri,<sup>a</sup> Martina Tuccillo,<sup>a</sup> and Stefano Cinti<sup>a,b</sup>

<sup>a</sup> *Department of Pharmacy, University of Naples "Federico II", Via Domenico Montesano 49, 80131 Naples, Italy*

<sup>b</sup> *Sbarro Institute for Cancer Research and Molecular Medicine, Center for Biotechnology, College of Science and Technology, Temple University, Philadelphia, PA 19122, USA*

*E-mail: [pkalligosfyri@gmail.com](mailto:pkalligosfyri@gmail.com)*

Additive manufacturing using 3D-printing is an emerging technology with a wide variety of applications, especially in the fabrication of sensing devices, due to its low cost, versatility, and sustainability. Various important parameters during the printing process affect the final 3D-printed sensors, including the use of different materials like flexible and conductive filaments [1]. These sensors are used for several applications, such as sensing copper for environmental purposes [2] and in the field of point-of-care diagnostic tools and wearables, for detecting several significant (bio)molecules such as viruses, lactic acid and glucose [3].

Exploiting the advantages of additive manufacturing, we have developed a 3D-printed electrochemical system (3D-PES) for decentralized sensing applications. Several important parameters were studied for the fabrication of the final 3D-PES: 1) dimension i.e. width, 2) the surface pattern of the 3D-printed electrodes, 3) the pretreatment process, and 4) the investigation of the reference electrode. Following these optimization studies, the ultimate all-in-one device was analytically characterized using potassium ferricyanide as a model analyte. A calibration curve was performed with increasing potassium ferricyanide concentration ranging from 0.05 to 1 mM. Additionally, reproducibility experiments were performed, taking into account the 3D-printing batches of the electrodes and the subsequent measurements. These studies of the proposed 3D-PES showed promising results, indicating that our sensing device has significant potential for real-world sample applications. In particular, the 3D-PES was analytically assessed, via preliminary experiments, for on-field testing and real-time monitoring of important analytes, such as substances related to the ripening of agricultural products and pesticides. This proposed system will provide significant advancements in the field of agriculture, offering farmers and specialists solutions for decision-making and protecting consumers.

[1] R. M. Cardoso, C. Kalinke, R. G. Rocha, P. L. dos Santos, D. P. Rocha, P. R. Oliveira, B. C. Janegitz, J. A. Bonacin, E. M. Richter, R. A. Munoz. *Anal. Chim. Acta* 1118 (2020) 73-91

[2] L. A. Pradela-Filho, D. A. Araújo, V. N. Ataíde, G.N. Meloni, Thiago RLC. Paixão. *Anal. Bioanal. Chem.* (2024) 1-12

[3] J. E. Contreras-Naranjo, V.H. Perez-Gonzalez, M.A. Mata-Gómez, O. Aguilar. *Electrochem. Commun.* 130 (2021) 107098

## Luminescent metal-organic frameworks for water remediation

Anna Mauri,<sup>a</sup> Gioele Colombo,<sup>a</sup> Jenny G. Vitillo,<sup>a,b</sup> and Simona Galli<sup>a,b</sup>

<sup>a</sup> *Dip. di Scienza e Alta Tecnologia, Università degli Studi dell'Insubria, Via Valleggio 9, 22100-Como, Italy*

<sup>b</sup> *Consorzio INSTM, via Giusti 9, 50121-Firenze, Italy*

E-mail: [amauri5@uninsubria.it](mailto:amauri5@uninsubria.it)

Water contamination by anthropogenic persistent organic pollutants (POPs) is a contemporary worldwide concern: they affect living organisms and the environment even in trace and are not degraded by traditional processes [1]. Luminescent metal-organic frameworks (LMOFs) are promising candidates in this context. MOFs are 3D open frameworks resulting from the self-assembly of inorganic nodes and organic linkers *via* coordination bonds [2]. Their crystallochemical features, hence functional properties, can be tuned *à la carte* through a sensible selection of nodes and spacers. Based on this, we focused on NU-1000 [3]  $[\text{Zr}_6(\text{O})_4(\mu\text{-OH})_4(\mu_3\text{-OH})_4(\text{H}_2\text{O})_4(\text{TBAPy})_2; \text{H}_4\text{TBAPy} = 1,3,6,8\text{-tetrakis-}(p\text{-benzoic acid})\text{-pyrene}]$ , a micro/mesoporous water-stable luminescent metal-organic framework with **csq** topology, (i) to study its sensing ability in aqueous solutions of exemplary POPs: diclofenac sodium (DCF), paracetamol, fluoxetine hydrochloride, and acetylsalicylic acid; (ii) as platform to introduce, *via* solvent-assisted linker incorporation, 2,5-thiophenedicarboxylic acid ( $\text{H}_2\text{TDC}$ ), aiming to modulate the functional behaviour.

Combining in-house powder X-ray diffraction, theoretical calculations, electronic absorption spectroscopy, and fluorescence emission spectroscopy, we disclosed that: (i) with a remarkable binding constant of  $2.4 \times 10^5 \text{ M}^{-1}$ , NU-1000 selectively detects DCF down to  $1.2 \times 10^{-6} \text{ M}$ , imparting a fluorescence intensity change statistically different from that of the other pollutants and bare dilution; (ii) NU-1000-HTDC, preserving the water stability and 3D architecture of the parent MOF, with  $\text{HTDC}^-$  dangling from the  $\text{Zr}^{\text{IV}}$ -based nodes, showed a completely different behaviour: irrespective of the pollutant, its fluorescence emission change is counterbalanced by the effect due to dilution.

Noteworthy, NU-1000 is a promising multi-functional material, *selectively sensing and quantifying DCF*. This study thus provides key information for future investigations of LMOFs as sensors for water remediation. Additionally, this work shows the strength and versatility of a multi-technique approach to disclose the crystallochemical and functional features of (L)MOFs intended for contemporary applicative challenges.

This study was carried out within the project «Wastewater treatment and monitoring with luminescent mixed-linker Metal-Organic Frameworks as chemical sensors and adsorbents of Contaminants of Emerging Concern (LUMIMOF)» funded by the Ministero dell'Università e della Ricerca within the PRIN 2022 program (D.D.104 02/02/2022), funded by the European Union - Next Generation EU, to which SG is grateful. AM acknowledges Università degli Studi dell'Insubria for a Ph.D. fellowship.

[1] S. Rojas, and P. Horcajada, *Chem. Rev.*, 120 (2020) 8378-8415.

[2] O.M. Yaghi, M. Kalmutzki, and C.S. Diercks, *Introduction to reticular chemistry* (2019), Wiley-VCH.

[3] N. Planas, J.E. Mondloch, S. Tussupbayev, J. Borycz, L. Gagliardi, J.T. Hupp, O.K. Farha, and J.C. Cramer, *J. Phys. Chem. Lett* 5 (2014) 3716-3723.

## Paper-based electrochemical sensor for the determination of hydrogen sulfide as biomarker for liquid biopsy

Antonella Miglione, Alessandra Glovi, Giuseppe Ercolano, and Stefano Cinti

Department of Pharmacy, University of Naples 'Federico II, Via D. Montesano 49, 80131, Naples, Italy

E-mail: [antonella.miglione@unina.it](mailto:antonella.miglione@unina.it)

Hydrogen Sulfide ( $H_2S$ ) is a biologically active endogenous gas, produced in mammalian tissues, which plays a critical role in several pathophysiological processes, including oncogenesis. Recent studies have indicated that this gas-transmitter may exert diametrically opposite effects on neoplastic cell proliferation, depending on the duration and concentration of  $H_2S$  exposure, so it could serve as a diagnostic marker, potentially indicating the presence of tumors in various body fluids and also the response to treatments [1]. Traditionally,  $H_2S$  is detected using spectrophotometric, chromatography, and fluorometric methods. However, the use of electrochemical sensors is a promising strategy to speed up and simplify operations [2]. In this context, an electrochemical sensor, screen-printed on chromatographic paper, and then modified with Prussian blue, was developed. After the optimization of various experimental parameters, such as the concentration of Prussian Blue to be used for the electrode modification and the constant potential applied during the chronoamperometric measurement, the sensor was analytically characterized in standard solution, achieving a good repeatability and a detection limit of  $3 \mu M$ . The sensor was then applied to determine  $H_2S$  in different tissue lysate samples, undergone to different treatments, obtaining results in agreement with those observed with the standard  $H_2S$  fluorescence method, demonstrating the satisfactory applicability of the developed electroanalytical method to real/complex matrices

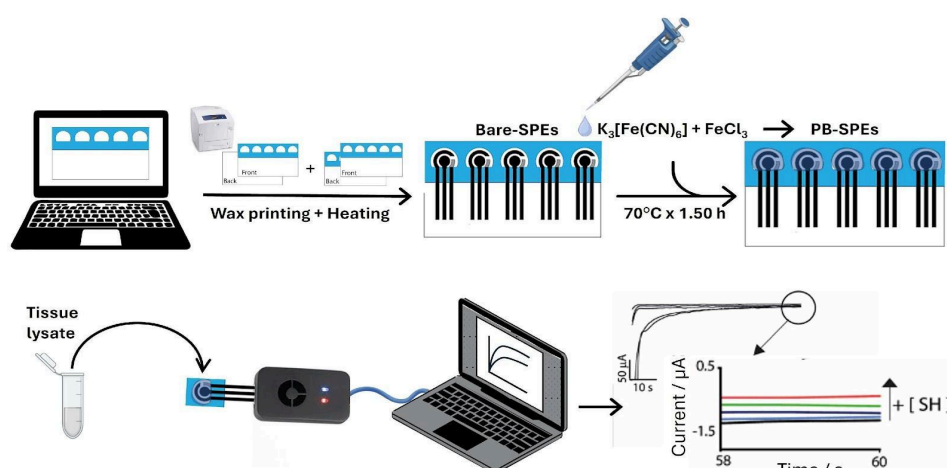

**Figure 1:** Schematic representation of the PB-SPEs production and analysis of the biological samples

[1] D. Wu, W. Si, M. Wang, S. Lv, A. Ji, and Y. Li, *Nitric Oxide* 50 (2015) 38-45

[2] G. K. Kolluru, X. Shen, and C.G. Kevil, *Expert Rev. Clin. Pharmacol.* 4 (2011) 9-12

**Porphyrins as versatile probes and modulators of small nucleic acid structures**

Gabriele Travagliante,<sup>a</sup> Massimiliano Gaeta,<sup>a</sup> Chiara Maria Antonietta Gangemi,<sup>b</sup> Roberto Purrello,<sup>a</sup> and Alessandro D'Urso<sup>a</sup>

<sup>a</sup> *Dipartimento di Scienze Chimiche, Università degli Studi di Catania, Viale A. Doria 6, 95125-Catania, Italia*

<sup>b</sup> *Dipartimento di Scienze chimiche, biologiche, farmaceutiche e ambientali, Università degli Studi di Messina, Viale Ferdinando Stagno d'Alcontres 31, 98166-Messina, Italia*

E-mail: [travagliantegab@gmail.com](mailto:travagliantegab@gmail.com)

Porphyrins are important macrocycles known for their roles in catalysis, oxygen transport, and electron transfer. Characterized by an intense absorption band in the 380–450 nm region, known as the Soret band, these highly electronic systems can generate induced circular dichroism (CD) signals upon interacting with chiral molecules. This phenomenon arises from the chiral distortion of the porphyrin symmetry or intermolecular exciton coupling between at least two chirally oriented chromophores [1]. While many studies have explored the use of achiral cationic or anionic porphyrins as chiroptical probes to investigate the secondary structures of various biomolecules in aqueous solutions, including polynucleotides, polypeptides, and proteins [2], there is a lack of research on the noncovalent interactions of achiral porphyrins with small RNA sequences which can adopt different secondary structures such as microRNAs (miRNAs) and RNA G-quadruplexes.

miRNAs are small noncoding RNAs that regulate gene expression by base-pairing with mRNA targets, affecting target degradation or translational repression. They play critical roles in processes such as immune response, hematopoiesis, developmental timing, cell death, and cell proliferation [3].

DNA and RNA G-quadruplexes (G4s) are four-stranded nucleic acid structures formed by guanine-rich sequences, essential for genomic stability and regulation. Telomeric repeat-containing RNA (TERRA) can form G4s, with important implications for telomerase inhibition in cancer therapy. Porphyrins can stabilize or destabilize these G4 structures, supporting in their structural study and potential therapeutic applications.

Herein, we studied the supramolecular interactions between achiral porphyrins and miRNAs, DNA, and RNA G-quadruplexes using several spectroscopic techniques, such as UV-Vis, fluorescence, resonance light scattering (RLS), electronic circular dichroism (ECD), and CD melting. This study underscores porphyrins' versatility as probes and modulators of nucleic acid stability, highlighting their potential in diagnostics and therapeutics.

[1] J. K. Choi, A. D'Urso, and M. Balaz, *J. Inorg. Biochem.* 127 (2013) 1-6

[2] I. G. Occhiuto, M. Samperi, M. Trapani, G. De Luca, A. Romeo, R. F. Pasternack, and L. M. Scolaro, *J. Inorg. Biochem.* 153 (2015) 361-36

[3] R. Schickel, B. Boyerinas, S. M. Park, and M. E. Peter, *Oncogene.* 27 (2008) 5959-5974

## Synthesis of mugineic acid family analogues as low cost and sustainable iron fertilizers for agriculture in poor soils

Andrea Masetti,<sup>1,2</sup> Rita Mazzoni,<sup>1</sup> Ryota Sato,<sup>2</sup> Sangita Karanjit,<sup>2</sup>  
Miho Yamaguchi,<sup>2</sup> and Kosuke Namba<sup>2</sup>

<sup>1</sup> Department of Industrial Chemistry "Toso Montanari", University of Bologna, Via P. Gobetti 85, 40129 Bologna, Italy

<sup>2</sup> Faculty of Pharmaceutical Sciences, Tokushima University, 〒770-8505 徳島市庄町1丁目78番地の1, Tokushima, Japan

E-mail: [andrea.masetti9@unibo.it](mailto:andrea.masetti9@unibo.it)

Plants require a diverse array of essential nutrients to carry out fundamental processes crucial for growth, development, and defense against environmental stressors. When these vital nutrients are lacking or insufficient in the soil, plants become susceptible to a range of adverse effects that compromise their health - amongst these, iron chlorosis is a prevalent and widely observed nutrient deficiency, frequently occurring in plants cultivated in calcareous soils, resulting in the manifestation of yellowing leaves, drastic reduction in crop yield and demise of individual limbs or the entire plant. The main remedial approach for iron chlorosis involves the application of iron chelates as fertilizers - however, the synthetic pathways currently in use to produce most commercial products trace their origins back to the 1970s, lacking sustainability and contributing to pollution.

To overcome this problem, we previously developed a synthetic pathway to 2'-deoxymugineic acid (DMA), a natural phytosiderophore from the *Poaceae* family, and proved that its application can recover Fe deficiency in plants grown in calcareous soil. However, the high cost and poor stability of synthetic 2'-deoxymugineic acid preclude its agricultural use [1]. In this work, we develop more stable and less expensive proline-derivative (PDMA) analogues of DMA and demonstrate their practical synthesis, ability to create stable complexes with Fe(III) via DFT calculations, and biological activity as iron fertilizers when applied on rice sprouts grown in alkaline conditions.

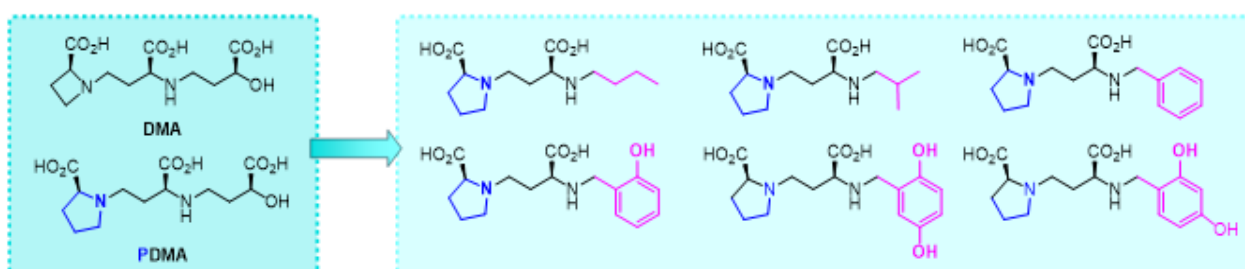

**Figure 1:** Previous results (*left*) and new differently substituted synthetic analogues of PDMA (*right*).

**Hybrid synthesis route for stable and swellable lignin nanoparticles**

Rossella Grappa,<sup>a</sup> Virginia Venezia,<sup>a</sup> Brigida Silvestri,<sup>b</sup> Giuseppina Luciani<sup>a</sup>, and Aniello Costantini<sup>a</sup>

<sup>a</sup> DICMaPI, Department of Chemical, Materials and Industrial Production Engineering, University of Naples Federico II, Naples, 80125-Naples, Italy

<sup>b</sup> Department of Civil, Architectural and Environmental Engineering, University of Naples Federico II, Naples, 80125-Naples, Italy

*E-mail: rossella.grappa@unina.it*

Lignin, the main by-product of the pulp and paper industry, is now emerging as a low-cost and renewable raw material for the development of new products and processes. In fact, its biocompatibility, intrinsic multifunctional features and safety make it a sustainable promising source for obtaining novel and value-added materials. However, its complex chemical structure and heterogeneous self-assembly behaviour pose several challenges. Nanostructured systems using lignin could address these issues, finding applications in food science, cosmetics, and healthcare [1]. The current study focused on the development of a novel hybrid synthesis method for lignin nanoparticles that combines top-down and bottom-up strategies. A significant improvement in the yield and performance of lignin nanoparticles is achieved. Not only the obtained nanoparticles feature improved the stability in various organic solvents, but they also exhibited reversible swelling features, thereby expanding their potential applications in various fields. Moreover, a deep evaluation on the functional performance of the obtained nanostructures has been performed. Specifically, the obtained lignin nanoparticles have demonstrated good antioxidant and antimicrobial activity. Therefore, the present research lay the foundations for an efficient and low-cost technological route for lignin valorization.

[1] M. Morsali; A. Moreno; A. Loukovitou; I. Pylypchuk. *Biomacromolecules* 2022, 23 (11), 4597–4606.

## Dual-functionality starch film with conductive and antibacterial properties enabled by dicationic ionic liquid plasticizers for flexible electronics

Susanna Romano,<sup>a</sup> Benedetta Brugnoli,<sup>b</sup> Chiara Frezza,<sup>a</sup> Giovanni Sotgiu,<sup>a</sup> Serena De Santis,<sup>a</sup> Daniele Rocco,<sup>a</sup> and Monica Orsini<sup>a</sup>

<sup>a</sup> Department of Industrial, Electronic and Mechanical Engineering, University of Roma Tre, via Vito Volterra 62, 00146 Rome (Italy)

<sup>b</sup> Department of Chemistry, University of Rome La Sapienza, Piazzale Aldo Moro 5, 00185 Rome (Italy)

E-mail: [susanna.romano@uniroma3.it](mailto:susanna.romano@uniroma3.it)

Over the years the use of petrol-based plastics has increased about 20 times in the last 50 years and their usage in many sectors has resulted in environmental problems. Natural polymers have been considered a replacement for common plastics, in this sense, starch is one of the most abundant polysaccharides found in plant storage organs and it is readily available. Nevertheless, starch is a brittleness material due to strong interactions among chains which confine their mobility [1]. To obtain effective starch films some plasticizers may be introduced that can improve the polymeric segmental mobility.

Recently, imidazolium-based ionic liquids (ILs) have been studied as new plasticizers due to their unique properties. In addition, ionic liquids, besides acting as plasticizers, can impart several useful properties to prepared films due to their antioxidant, antibacterial and conductive activities [2]. Lately, dicationic ionic liquids (DILs), a new category of ILs family, attracted great concern as it represents an interesting variation of the cationic partner.

In this work, the influence of the type and the length of the linkage chain on film properties will be discussed through different techniques, such as the Fourier Transform Infrared Spectroscopy (FT-IR), Electrochemical Impedance Spectroscopy (EIS) and performing mechanical and antimicrobial activity tests.

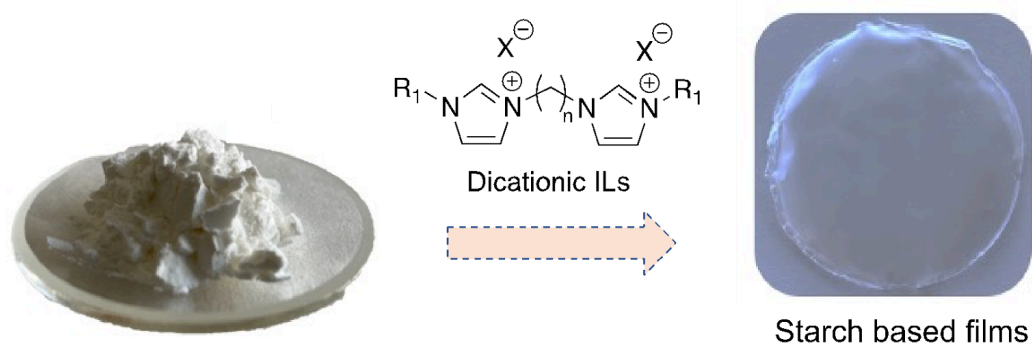

**Figure 1:** Plasticizing effect of DILs in producing starch-based films

[1] Z. N. Diyana, R. Jumaidin, M. Z. Selamat, I. Ghazali, N. Julmohammad, N. Huda and R. A. Ilyas, Physical Properties of Thermoplastic Starch Derived from Natural Resources and Its Blends: A Review, *Polymers*, **2021**

[2] A. Sankri, A. Arhaliass, I. Dez, A. C. Gaumont, Y. Grohens, D. Lourdin, I. Pillin, A. Rolland-Sabaté, E. Leroy, Thermoplastic starch plasticized by an ionic liquid, *Carbohydrate Polymers* **82**, 2010, 256-263

## OR076

### Biomass valorization: antioxidant supramolecular ionic liquid gels from cellulose acetate and cellulose

Giovanna Raia,<sup>a</sup> Salvatore Marullo,<sup>a</sup> Francesca D'Anna<sup>a</sup>

<sup>a</sup> STEBICEF, Università degli Studi di Palermo, Viale delle Scienze Ed.16, CAP-90128, Italy

E-mail: [giovanna.raia@unipa.it](mailto:giovanna.raia@unipa.it)

Gels are soft materials, very common in everyday life (toothpaste, hair gels), and used in a wide range of applications, for example to remove emerging pollutants from wastewaters [1], or in controlled drug release [2]. On the other hand, nowadays, the use of lignocellulosic biomass has sparked great interest due to its abundance, eco-compatibility, and renewability. In addition, it does not compete with food production, and can be obtained at lower costs as compared to agriculturally valuable food crop feedstocks.

This work presents the use of biomass-derived polymers and ionic liquids to obtain gels. In particular, cellulose acetate and cellulose are employed as gelators while ionic liquids are used as solvent. We tested their swelling, porosity and self-healing ability. We also carried out rheological analysis, which revealed peculiar rheological properties. Finally, we evaluated their antioxidant ability using the 2,2-diphenyl-1-picrylhydrazyl radical (DPPH) assay, and we found that some of them are efficient as antioxidants.

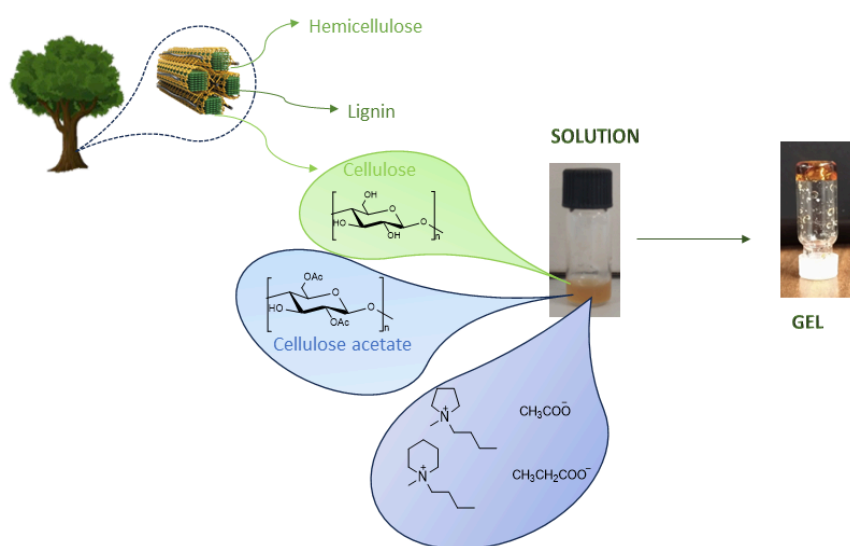

**Figure 1:** General scheme.

**Acknowledgement:** Finanziato dall'Unione europea – Next Generation EU” PRIN 2022 PNNR

(P20223ZFXH CUP: P20223ZFXH\_003) [1] S. Marullo, F. D'Anna, *Advanced Sustainable Systems*, 2024, doi 10.1002/adssu.202300639

[2] J. A. Sa'ez, B. Escuder, J. F. Miravet, *Chem. Commun.*, 46, (2010), 7996–7998

**Humic acids as selective sorbents of precious metals from WEEE**

Virginia Venezia,<sup>a</sup> Rossella Grappa,<sup>a</sup> Luigi Piero Di Bonito,<sup>b</sup> Brigida Silvestri,<sup>c</sup> Francesco Di Natale,<sup>a</sup> and Giuseppina Luciani<sup>a</sup>

<sup>a</sup> *Dept. of Chemical, Materials and Production Engineering, University of Naples Federico II, Piazzale Tecchio, 80, 80125, Napoli, Italia*

<sup>b</sup> *Department of Mathematics and Physics, University of Campania Luigi Vanvitelli, Viale Abramo Lincoln, 5, 81100, Caserta, Italia*

<sup>c</sup> *Dept. of Civil, Architectural and Environmental Engineering, University of Naples Federico II, Piazzale Tecchio, 80, 80125, Napoli, Italia*

E-mail: [virginia.venezia@unina.it](mailto:virginia.venezia@unina.it)

Rapid technological advances have led to an increase in Waste Electrical and Electronic Equipment (WEEE), which contains hazardous elements such as lead, mercury and flame retardants that release dioxins when incinerated, posing serious environmental and health risks [1]. WEEE is rich in valuable metals such as copper, iron, nickel, silver, gold and platinum. For example, one tonne of e-waste can contain up to 0.2 tonnes of copper, and discarded mobile phones have high concentrations of gold. Therefore, WEEE is an important source for precious metals recovery, which is essential to meet sustainable demand for metal resources and support the circular economy [1].

This work investigates a biosustainable method for the recovery of precious metals from WEEE, focusing on the valorisation of biowastes, using biomolecules such as humic acids (HA). Specifically, two types of HA extracted from different biowastes were tested as potential sorbents for precious metal ions. The study evaluated the uptake capacity of these biomolecules for three metal ions - Au<sup>3+</sup>, Pd<sup>2+</sup> and Cu<sup>2+</sup>, under different conditions, including changes in pH, temperature and metal ion concentrations. Both biosorbents exhibited excellent adsorption capacities for both gold and palladium ions, especially at pH 3, reaching adsorption efficiency of about 300 mg/g of biosorbent and 200 mg/g of biosorbent of Au<sup>3+</sup> and Pd<sup>2+</sup> ions, respectively, while they showed no significant interaction with copper ions. The selectivity of the sorbents was evaluated in multi-metal solutions, confirming that effective adsorption requires simultaneous adsorption and reduction processes.

The use of biowaste-derived sorbents for metal recovery from WEEE is a promising technological solution in line with circular economy principles. In addition, this approach offers an environmentally friendly and cost-effective alternative to traditional electrochemical reduction processes.

This work was supported by MITE (ora MASE - Ministero dell'Ambiente e della Sicurezza Energetica) Progetto di ricerca PEsMeNo – "Processi rigenerativi ecoSostenibili per il recupero e la valorizzazione di Metalli Nobili da RAEE".

[1] J. K. Bediako, J. W. Choi, M. H. Song, Y. Zhao, S. Lin, A. K. Sarkar, ... & Y. S. Yun, *Waste manag.* (2020), 113, 225-235.

## Optimization of a natural three-component solvent mixture for the extraction of phenolic compounds from by-products

Federica Alchera, Claudio Cecone, and Marco Ginepro

Department of Chemistry, University of Turin, Via Pietro Giuria, 7, 10125 Turin, Italy

E-mail: [federica.alchera@unito.it](mailto:federica.alchera@unito.it)

Food production and consumption generate large amounts of biomass waste from processing, which poses a serious disposal problem.

In a circular economy approach, it is crucial to recover the waste produced, given the high value of the by-products due to the presence of active compounds (polyphenols). The conventional methods for extracting phytochemicals are based on the use of organic solvents such as a mixture of water and ethanol, methanol or acetone. Therefore, the use of alternative solvents has become crucial in the context of the development of “green chemistry”. Recently, natural deep eutectic solvents (NADES) have been studied as green solvents. NADES are composed of natural components, and meet the requirements of biodegradability, sustainability, low toxicity, low cost and ease of production [1]. One of the greatest advantages of NADES is that the solvent mixture can be modulated, considering the final application of the extract (e.g. sugar-based NADES for cosmetics and food packaging).

Based on our previous study focused on the optimization of extraction conditions for a three-component solvent we explore, using a Design of Experiment approach, the influence of each single component on the extraction efficiency [2]. The correct amount of three factors (NADES lactic acid:glucose; glycerin and water) were explored to achieve the higher polyphenol concentration in the extract (TPC). The optimized extract was characterized, and a possible correlation between viscosity and extraction efficiency of different solvent mixtures was studied using a rheometer. Finally, the natural extract obtained was applied in cosmetics. The extract was used as an active agent in an alginate-based hydrogel. The hydrogel obtained was studied and characterized for possible use as a biodegradable anti-ageing mask.

[1] L. Benvenuti, A.A.F. Zielinski, S.R.S. Ferreira, *Trends in Food Science & Technology* 90 (2019) 133–146

[2] F. Alchera, M. Ginepro, G. Giacalone, *LWT* 192 (2024) 115642

## OR079

### Cluster formation of water-based Deep Eutectic Solvents (*aquo*DESs) in water

Elison Lepore,<sup>a</sup> Gianluca Ciancaleoni,<sup>b</sup> Diego Romano Perinelli,<sup>a</sup> Giulia Bonacucina,<sup>a</sup> Serena Gabrielli,<sup>c</sup> Gaia de Simone,<sup>a</sup> Rosita Gabbianelli,<sup>a</sup> Laura Bordoni,<sup>a</sup> and Matteo Tiecco<sup>a</sup>.

<sup>a</sup> Scuola di Scienze del Farmaco e Prodotti della Salute, Università di Camerino, via Madonna delle Carceri, 63032 Camerino (MC), Italy

<sup>b</sup> Dipartimento di Chimica e Chimica industriale, Università di Pisa, via Giuseppe Moruzzi 13, I-56124 Pisa, Italy

<sup>c</sup> Scuoladi Scienze e Tecnologie, Università di Cmaerino, Via S. Agostino 1, 62032, Camerino (MC), Italy.

E-mail: elison.lepore@unicam.it

Deep Eutectic Solvents (DESs) are an innovative class of organic solvents that are increasing their importance in the research activity thanks to their environmental-friendly features as well as to their structural characteristics and catalytic properties. Formed by no-solvent mixing of two substances, namely a hydrogen bond donor and a hydrogen bond acceptor, DESs are finding fruitful applications in many different topics as alternatives to common organic compounds[1]. One of the most interesting and studied properties of DESs is their peculiar water dilutions structures, because the DESs retain their structural features until high water contents (until about 50% w/w), showing clusters of DESs solvated by water in equilibrium with free-solvated species. The disruption of the DESs' structures occurs over 60% w/w of water added [2]. In this presentation the properties of water dilutions of *aquo*DESs (binary DESs formed with water mixed with counterparts over their maximum solubility)[3] will be shown. Clusters of water-based systems in water were observed and characterized with techniques such as ionic conductivity; rheological measures; high resolution ultrasound spectroscopy; PGSE NMR. Finally, the cytotoxicity of these water dilutions of water-based DESs was tested in an in vitro model of intestinal cell culture (Caco-2) by MTT assay.

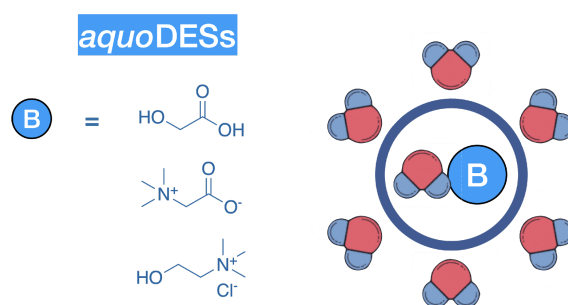

**Figure 1:** water-based DESs' clusters in water dilutions..

[1] D. A. Alonso, S. J. Burlingham, R. Chinchilla, G. Guillena, D.J. Ramón, M. Tiecco, EurJOC 2021, 29, 4065 - 4071.

[2] F. Gabriele, M. Chiarini, R. Germani, M. Tiecco, N. Spreti, J Mol Liq 2019, 291, 111301.

[3] E. Picciolini, G. Pastore, T. Del Giacco, G. Ciancaleoni, M. Tiecco, R. Germani, J Mol Liq 2023, 383, 122057.

**New solutions for the protection of concrete heritage by means of sustainable corrosion inhibitors and nanocarriers**

Chiara FRATELLO,<sup>a,b\*</sup> Elena MESSINA,<sup>a</sup> Francesca BOCCACCINI,<sup>a</sup> Cristina RICCUCCI,<sup>a</sup> Marianna PASCUCCI,<sup>a</sup>, and Gabriella DI CARLO<sup>a</sup>

<sup>a</sup> *Institute for the Study of Nanostructured Materials (ISMN), National Research Council (CNR), SP35d, 9, 00010 Montelibretti, Rome*

<sup>b</sup> *Department of Chemical Engineering Materials Environment, Sapienza University of Rome, Via Eudossiana, 18, 00184, Rome*

*E-mail: chiara.fratello@uniroma1.it*

The corrosion of steel reinforcing bars in concrete strongly impacts its stability, causing the formation of rust and other products that lead to mechanical stress and structural damages, with consequences both on safety and economics [1]. The main triggering factor of this process can be identified in the loss of the passivating oxide layer that is usually present in fresh concrete, due to the high pH values, which becomes less stable while the carbonation proceeds or the chloride concentration increases. Advanced corrosion may necessitate invasive interventions; however, for concrete heritage, this is not advisable. Therefore, it is essential to preserve the integrity of the steel rebars to ensure the long-term preservation of the cultural asset [2]. Commercially available corrosion inhibitors can help slow these processes, but most of them are not able to satisfactorily reach the rebar by migrating into the concrete porosity, like amines, that are usually volatile, or contain heterocyclic compounds (i.e. benzotriazole), that are harmful to operators and toxic to the environment. This research aims to seek increasingly *green* solutions that are not only effective but also safe to use, by identifying new inhibitors for steel in concrete. In addition, as in the field of protection of cultural heritage the inhibitor can only be applied on the surface of concrete, an ideal product has to be able to migrate into the innermost layers until it reaches the rebars. Part of this research is, therefore, also focused on the synthesis and validation of carrier systems that can deliver these inhibitors through the cement matrix and release them upon environmental stimuli (pH change, presence of chlorides) such as layered double hydroxides [3]. The current research began with validating some corrosion inhibitors after 5 years of treatments, a particularly relevant analysis as these tests are usually conducted over shorter timescales. To evaluate their efficacy, a multi analytical approach was chosen using optical and metallographic microscopy, as well as FTIR and SEM analysis of corrosion products on the surface.

[1] Poursaee, A.; Hansson, C. M. Potential Pitfalls in Assessing Chloride-Induced Corrosion of Steel in Concrete. *Cem. Concr. Res.* 2009, 39 (5), 391–400.

[2] Bertolini, L.; Carsana, M.; Gastaldi, M.; Lollini, F.; Redaelli, E. Corrosion Assessment and Restoration Strategies of Reinforced Concrete Buildings of the Cultural Heritage. *Mater Corros* 2011, 62 (2), 146–154.

[3] Giuliani, C.; Messina, E.; Staccioli, M. P.; Pascucci, M.; Riccucci, C.; Liotta, L. F.; Tortora, L.; Ingo, G. M.; Di Carlo, G. On-Demand Release of Protective Agents Triggered by Environmental Stimuli. *Front. Chem.* 2020, 8, 304.

## Exploring the interaction of novel ruthenium(II) polypyridyl complexes with G-Quadruplex structures in mitochondrial DNA

Laura Marretta, Alessio Terenzi, and Giampaolo Barone

*Dipartimento di Scienze e Tecnologie Biologiche Chimiche e Farmaceutiche, Università degli Studi di Palermo, Viale delle Scienze, 17, 90128-Palermo, Italy*

*E-mail: laura.marretta02@unipa.it*

Over the past few decades, G-Quadruplex DNA (G4) has been extensively studied and well-established as a secondary DNA structure within guanine-rich sequences in human nuclear DNA. These structures, although still requiring further functional exploration, are recognized for their crucial roles in cellular biology and are considered promising targets for anticancer drug development [1]. Recently, G4 formation has also been detected in mitochondrial DNA (mtDNA), suggesting a potential regulatory function in mitochondrial processes. This is particularly significant as mitochondria play a central role in cellular metabolism, and their dysfunction is closely linked to several cancer hallmarks [2]. In parallel, ruthenium complexes have been demonstrating promising anticancer activity. The presence of polypyridyl ligands allows them to localize to mitochondria, where they induce apoptosis or necrosis in cells. Additionally, Ru(II) compounds with dipyrido[3,2-a:2',3'-c]phenazine (dppz) ligands have shown an affinity for G4 structures [3].

To investigate the effects of G4-interacting compounds on mtDNA G4s, we synthesized a series of novel Ru(II) complexes:  $[\text{Ru}(\text{bipy})_2(\text{L})]$  and  $[\text{Ru}(\text{phen})_2(\text{L})]$ , with L being a modified dppz ligand (Figure 1). Particularly, the dppz was functionalized with a triphenylphosphonium moiety, known for its mitochondrial targeting properties. We examined their interactions with mitochondrial G4 sequences utilizing various spectroscopic techniques, including UV-Vis absorption, fluorescence, circular dichroism, and FRET. Preliminary results have shown that our new compounds exhibit promising binding properties with mtDNA G4 structures.

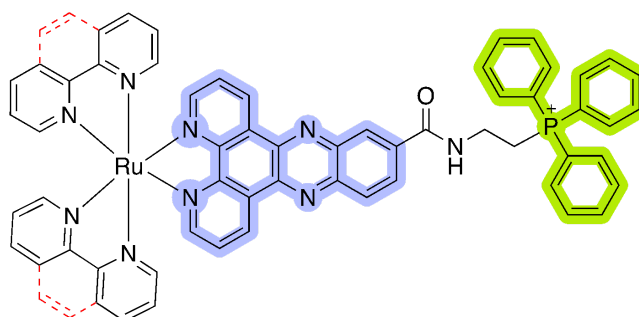

**Figure 1:** Structure of the newly synthesized compounds. The central Ru atom can coordinate either two molecules of bipyridine (in black) or two phenanthrolines (in red). The dppz molecule is highlighted in blue, and the triphenylphosphonium moiety is shown in green.

[1] D. Varshney, J. Spiegel, K. Zyner, D. Tannahill, S. Balasubramanian. *Nat. Rev. Mol. Cell Biol* (2020), 21, 459.

[2] V.J. Sahayasheela, Z. Yu, T. Hidaka, G. N. Pandian, H. Sugiyama. *Trends Genet.* (2023), 39, 15.

[3] K. McQuaid, J. P. Hall, L. Baumgaertner, D. J. Cardin, C. J. Cardin. *Chem. Commun.* (2019), 55, 9116.

## Development of an engineered viral carrier for EGFR-targeted photodynamic therapy

Nicolò Mercorelli,<sup>a</sup> Roberto Saporetti,<sup>a</sup> Alessia Marconi,<sup>a</sup> Matteo Di Giosia,<sup>a</sup> Alena Kaltenbrunner,<sup>b</sup> Paolo Emidio Costantini,<sup>b</sup> Alberto Danielli,<sup>b</sup> and Matteo Calvaresi<sup>a</sup>

<sup>a</sup> Dipartimento di Chimica “Giacomo Ciamician”, Alma Mater Studiorum–Università di Bologna, Via Francesco Selmi 2, 40126-Bologna, Italy

<sup>b</sup> Dipartimento di Farmacia e Biotecnologie, Alma Mater Studiorum–Università di Bologna, Via Francesco Selmi 3, 40126-Bologna, Italy  
E-mail: nicolo.mercorelli2@unibo.it

Photodynamic therapy (PDT) is a clinically approved therapeutic modality for cancer. PDT is characterized by high selectivity and minimal side effects [1]. The success of PDT is usually limited by the lack of selective accumulation of the photosensitizer (PS) in cancer cells, resulting in unwanted phototoxicity.

Temoporfin (mTHPC), a clinically approved chlorin-based PS, has a very high potential in PDT. However, its application is hampered by its lipophilic character. Human Serum Albumin (HSA), the most abundant carrier protein in the blood, can be used as supramolecular host for mTHPC (mTHPC@HSA) [2].

Bacteriophages (phages) are ubiquitous viruses that infect bacteria but are inactive against eukaryotic cells [3]. Refactored M13 phages, with targeted tropism against EGFR, were generated through phage display of a nanobody able to recognize the EGF receptor. Using SPAAC (strain promoted azide alkyne cycloaddition) click chemistry reaction, the surface of the viral capsid was decorated with the supramolecular complex mTHPC@HSA. With this orthogonal workflow, M13 was transformed into a selective carrier for mTHPC, improving both its selectivity and biocompatibility.

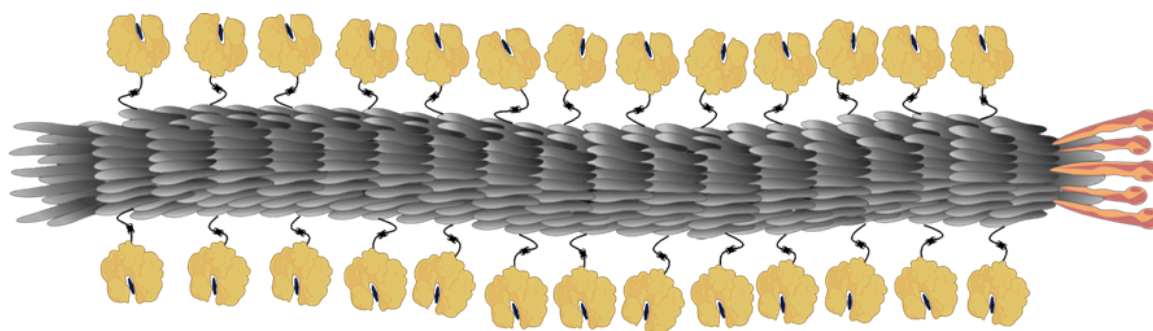

**Figure 1:** Graphical representation of M13-mTHPC@HSA bioconjugate

[1] D. E. J. G. J. Dolmans, D. Fukumura and R. K. Jain, Nat. Rev. Cancer, 2003, 3, 380–387

[2] Mattioli, E.J.; Ulfo, L.; Marconi, A.; Pellicioni, V.; Costantini, P.E.; Marforio, T.D.; Di Giosia, M.; Danielli, A.; Fimognari, C.; Turrini, E.; et al. Carrying Temoporfin with Human Serum Albumin: A New Perspective for Photodynamic Application in Head and Neck Cancer. Biomolecules 2023, 13, 68.

[3] Sunderland, K. S.; Yang, M.; Mao, C., Phage-Enabled Nanomedicine: From Probes to Therapeutics in Precision Medicine. Angewandte Chemie International Edition 2017, 56 (8), 1964-1992.

---

## OR083

### A spoonful of sugar helps the medicine go down: 3D printing in the era of personalized pharmaceuticals

Mattia Tiboni, Costanza Fratini, Annalisa Aluigi, and Luca Casettari

*Department of Biomolecular Sciences, University of Urbino Carlo Bo, Via Ca' Le Suore, 2, 61029-Urbino, Italy*

*E-mail: [mattia.tiboni@uniurb.it](mailto:mattia.tiboni@uniurb.it)*

3D printing has found extensive use in the pharmaceutical industry and is leading the way in innovative development for drug delivery. Rapid prototyping enables to create fully customizable products (e.g., size, shape, release kinetics, and drug loading) quickly, precisely, and affordably [1]. This study determines the feasibility of using 3D printing to produce small batches of pediatric oral gummies chosen as appealing dosage forms to increase the acceptance of the treatment thus the compliance to therapy.

Propranolol HCl has a well-documented history of safety in pediatric therapy for the treatment of cardiac diseases (e.g., supraventricular tachycardia, hemangiomas). However, only tablets prescribed for adults (40 mg of PR per tablet) and an oral liquid formulation (Hemangiol® 3.75 mg/mL) are present on the market driving us in the selection of this active ingredient.

Rheology was used to determine the suitability of preformulated hydrogels composed of sodium alginate and iota-carrageenan in terms of extrudability and printing resolution. The most promising hydrogels were tested using a 3D printer (BioX, Cellink, Sweden). Propranolol HCl was added at a concentration of 4% w/w and heart shaped gummies were printed (Figure 1) and characterized by Fourier-transform infrared spectroscopy (FTIR), content uniformity, drug loading, and drug release

Bioprinting demonstrates to be a rapid and cost-effective manufacturing process to obtain small batches of child-friendly gummies with the possibility to employ different polymer blends. In this scenario, the potential to move one step closer to the objective of personalized therapy is clear, especially when it comes to implement the setting with formulations specifically designed for pediatric care.



**Figure 1:** 3D printed gummies.

[1] Goyanes, A.; Wang, J.; Buanz, A.; Martínez-Pacheco, R.; Telford, R.; Gaisford, S.; Basit A.W., *Mol. Pharm.*, 12, 11, (2015) 4077–4084.

## Unlocking the potential of ferritin-platinum bioconjugates: a novel approach to cancer therapy

Valentina Vitali and Luigi Messori

Department of Chemistry "Ugo Schiff", University of Florence, Via della Lastruccia 3, 50019 Sesto Fiorentino, Italy

E-mail: [valentina.vitali@unifi.it](mailto:valentina.vitali@unifi.it)

Current cancer therapies using platinum-based drugs often suffer from limitations like off-target toxicity and resistance development. Human heavy-chain ferritin (HuHf) has emerged as a valid alternative in the never-ending fight against tumors. This promising nanocarrier protein has already been exploited for the selective delivery of cytotoxic gold drugs to cancer cells [1]. Its high affinity for the transferrin receptor-1 (TfR1), overexpressed in many cancer cell lines [2] (**Figure 1**), makes HuHf an appealing candidate for developing novel therapeutic strategies. Therefore, combining ferritin's high selectivity against tumoral tissues with the well-known cytotoxic profile of platinum drugs could create novel interesting bioconjugates with improved pharmacological profiles and, hopefully, reduced toxic side effects. Here a systematic investigation of the conjugation between HuHf and a panel of platinum-based drugs, including cisplatin and its derivatives, has been carried out. Peptide fragmentation combined with ESI-MS spectrometry and ICP analysis has been extensively exploited to characterize these adducts. The biological activity of the ferritin-platinum compounds bioconjugates has been extensively tested against ovarian cancer cell lines (A2780 sensitive and resistant to cisplatin) and the resulting IC50 values were compared with the ones obtained for the corresponding free metallodrug. Ferritin-platinum bioconjugates hold significant promise as a novel approach for cancer therapy. Their potential enhanced selectivity towards cancer cells and possibility to overcome cisplatin resistance could lead to improved anticancer therapeutic efficacy and reduced side effects.

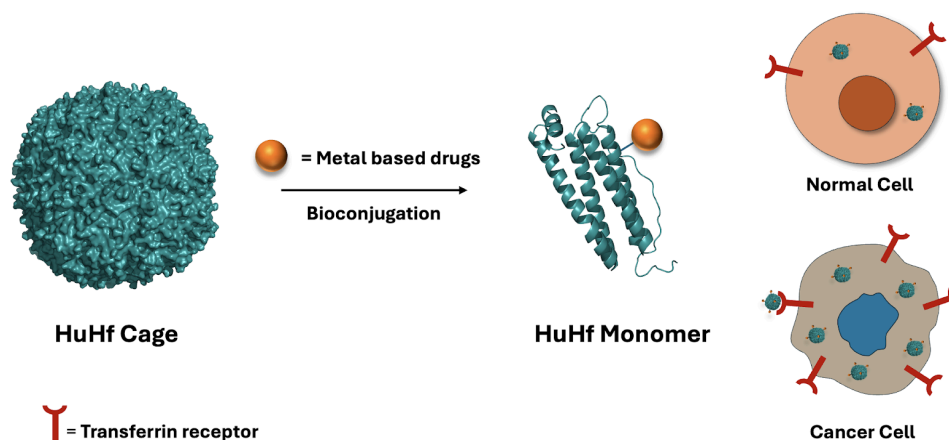

**Figure 1:** Schematic representation of the bioconjugation reaction between HuHf and platinum metal base drugs.

[1] L. Cosottini, L. Massai, V. Ghini et al, *J. J Drug Deliv Sci Techno.* 87 (2023) 104822.

[2] T. R. Daniels, E. Bernabeu, J.A.Rodriguez et al, *Biochim Biophys Acta.* 2012, 1820 (3), (2020) 291-317

## Exploring the potential of metal-based compounds as antibacterial agents: the case of thioredoxin reductase from *Burkholderia cenocepacia*

Stefano Zineddu, and Luigi Messori

Dipartimento di Chimica "Ugo Schiff", Università degli Studi di Firenze, Via della Lastruccia 3, 50019, Sesto Fiorentino, Italy Address, CAP-City, Country

E-mail: [stefano.zineddu@unifi.it](mailto:stefano.zineddu@unifi.it)

Bacteria belonging to the *Burkholderia cepacia* complex (Bcc) are notorious Gram-negative opportunistic pathogens, particularly problematic for individuals with cystic fibrosis [1]. These bacteria, like *Burkholderia cenocepacia*, possess elaborate evasion mechanisms against multiple classes of antimicrobials, which are partially responsible for the significance of their infections. For these reasons there is an urgent need for novel antibiotics that can counter the escalating threat posed by antibiotic-resistant bacteria.

One strategy to tackle this crisis involves repurposing existing drugs, such as gold(I)-based drug, which are known to possess high affinity towards proteins' free thiols and have shown bactericidal activity against Gram-positive bacteria, like auranofin [2]. Auranofin achieves this by inhibiting thioredoxin reductase (TrxB) and disrupting the cell's ability to endure oxidative stress. However, its effectiveness is limited against many Gram-negative bacteria, with the reasons not entirely clear—whether it's due to variances in cell envelope permeability or the presence of glutathione reductase (GOR), an enzyme which is functionally and structurally similar to TrxB.

Here we investigate the interactions of TrxB from *B. cenocepacia* with a selected set of gold(I)-based compounds through an ESI-MS approach. Generally, the analysis of the obtained spectra revealed the formation of stable adducts. Overall, the present results set the stage to better understand the mechanism of action of these compounds and to elucidate their antimicrobial activity.

[1] JC. Gutiérrez Santana and VR. Coria Jiménez, *Ann. Med.* (2024) 56(1)

[2] F. Coscione, S. Zineddu, V. Vitali, M. Fondi, L. Messori and E. Perrin, *Antibiotics* (2024) 13(7) 652

## Decoding Inflammation: The Exciting Challenge of Oxylipin Analysis

Denise Biagini,<sup>a</sup> Silvia Ghimenti,<sup>a</sup> Alessio Lenzi,<sup>a</sup> Thierry Durand,<sup>b</sup> Tommaso Lomonaco,<sup>a</sup>  
and Fabio Di Francesco<sup>a,c</sup>

<sup>a</sup> *Department of Chemistry and Industrial Chemistry, University of Pisa, Pisa, Italy*

<sup>b</sup> *Institut des Biomolécules Max Mousseron IBMM, UMR 5247 CNRS, Université de Montpellier, ENSCN,  
France*

<sup>c</sup> *National Interuniversity Consortium for Materials Science and Technology (INSTM), Via G. Giusti, 9, 50121  
Firenze, Italy*

*E-mail: denise.biagini@dcci.iunipi.it*

Besides cytokines, oxylipins are important signaling molecules derived respectively from the enzymatic and non-enzymatic oxidation of polyunsaturated fatty acids (PUFAs). The production of these lipid mediators is considerably increased during inflammation and oxidative stress, which play a key role in the pathogenesis and pathophysiology of a great number of diseases. The analysis of these metabolites in biological specimens can be extremely useful in elucidating their biological activity and potential biomarker role in the clinical setting. Their quantification represents a very challenging task due to the very low concentration levels (ppts range) and the tiny amount of sample available.

Here, we illustrate an innovative analytical platform that combines the micro-extraction by packed sorbent technique with ultra-high performance liquid chromatography coupled to electrospray ionization-tandem mass spectrometry for the determination of oxylipins and PUFAs in various biofluids (e.g., plasma, oral fluid, dried blood spots, fingernails). The analytical platform has proven highly effective in delivering a comprehensive characterization of the inflammatory process in a wide range of clinical settings, from newborns to the elderly.

We believe that the targeted modulation of endogenous mechanisms of inflammation, rather than its simple suppression, will soon become a key approach to treating chronic diseases.

**Data-independent acquisition proteomics for the discovery of chicken meat authenticity biomarkers: a study on breasts from two chicken strains raised under organic and antibiotic-free farming systems**

Laura Alessandroni <sup>a</sup>, Gianni Sagratini <sup>a</sup>, and Mohammed Gagaoua <sup>b</sup>

<sup>a</sup>*Scuola di Scienze del Farmaco e dei Prodotti della Salute, Chemistry Interdisciplinary Project (ChIP), Università degli Studi di Camerino, 62032, Camerino, Italy*

<sup>b</sup>*PEGASE, INRAE, Institut Agro, 35590 Saint-Gilles, France*

Email: [laura.alessandroni@unicam.it](mailto:laura.alessandroni@unicam.it)

In chicken farming, numerous factors such as feeding, lifespan, rearing and pre-slaughter conditions, can affect the physiology and metabolic processes of the animals, which may consequently affect the final meat quality. Organic meat production systems aim to provide high quality products in a more sustainable manner, based on high animal welfare standards [1]. Proteomics is the comprehensive characterization of the expressed proteins in a biological system at a specific time [2]. In the present research, the early post-mortem *Pectoralis major* muscle proteomes from Ranger Classic and Ross 308 chicken strains, produced under two different farming systems – organic and antibiotic-free – were studied. A shotgun SWATH-MS proteomics approach through a TripleTOF device working in Data-Independent Acquisition mode, was used [3]. A total of 660 proteins were simultaneously identified and quantified. The high number of samples (10 for each of the 4 groups) allowed the application of chemometrics methods, for instance Partial-Least Square Discriminant Analysis (PLS-DA), which enabled a clear group discrimination. Chicken strains were distinguished by 73 differentially expressed proteins within the antibiotic-free groups and by 62 within the organic farming system. Among Ross 308 groups, 71 differentially expressed proteins discriminated the farming system and among Ranger Classic, they were 52. The statistically significant abundant proteins were investigated through bioinformatics and were found to belong to interconnected metabolic pathways mainly driven by energy metabolic pathways and muscle structure. The combination of chemometrics and bioinformatics allowed to reveal the intricate relationships between the influence of farming practices and chicken strains on the post-mortem meat proteome. This work represents a major advancement in chicken breast meat proteome understanding and might pave the way to new methods for determining the authenticity of meat and meat products.

[1] A. El-Deek, & K. El-Sabrouh. *Worlds Poult Sci J*, (2019), 75(1), 105-114.

[2] M. Gagaoua, D. Franco, & R. Ramanathan. *Journal of Proteomics*, (2024), 295, 105090.

[3] L. Alessandroni, G. Sagratini, S.B. Bravo, and M. Gagaoua. *Current Research in Food Science*, (2024), 8, 100757.

OR088

## Comprehensive proteomic analysis of auranofin and its halogen analogues in ovarian cancer A2780

Andrea Geri,<sup>a</sup> Lara Massai,<sup>a</sup> Luigi Messori,<sup>a</sup> and Giovanni Chiappetta<sup>b</sup>

<sup>a</sup> Department of Chemistry "Ugo Schiff", University of Florence, Via della Lastruccia 13, 50019, Sesto Fiorentino, Italy

<sup>b</sup> Biological Mass Spectrometry and Proteomics Group, ESPCI Paris, PSL University, 10 rue Vauquelin, 75005, Paris

E-mail: andrea.geri@unifi.it

Gold-based drugs, in particular auranofin (AF) and its analogues, are attracting increasing attention as a novel class of drugs with potential application in cancer treatment. Several studies have demonstrated the efficacy of AF against the ovarian cancer cell line A2780 and its ability to overcome cisplatin resistance [1]. The development and optimization of these novel drugs requires a comprehensive understanding of their interactions within the intracellular environment. This study aims to investigate the effects of auranofin and its analogues, designed by replacing the thiosugar moiety with a halogen ligand, on the A2780 ovarian cancer cells. We performed comprehensive mass spectrometry (MS)-based proteomics studies (LC-Q-TOF) to elucidate the altered pathways and define the precise molecular targets.

Bioinformatic analyses support the view that the most critical cellular changes induced by AF treatment consist of thioredoxin reductase inhibition, alteration of the cellular redox state, impairment of mitochondrial functions, metabolic changes associated with conversion to a glycolytic phenotype and induction of ER stress [1]. The proteomic signatures of the halogen analogues are very similar to those of auranofin, suggesting a substantially conserved cytotoxic mechanism. It appears that AF and its analogues exert their cellular effects through multi-target mechanism, mainly affecting the redox metabolism and mitochondrial functions of A2780 cancer cells.

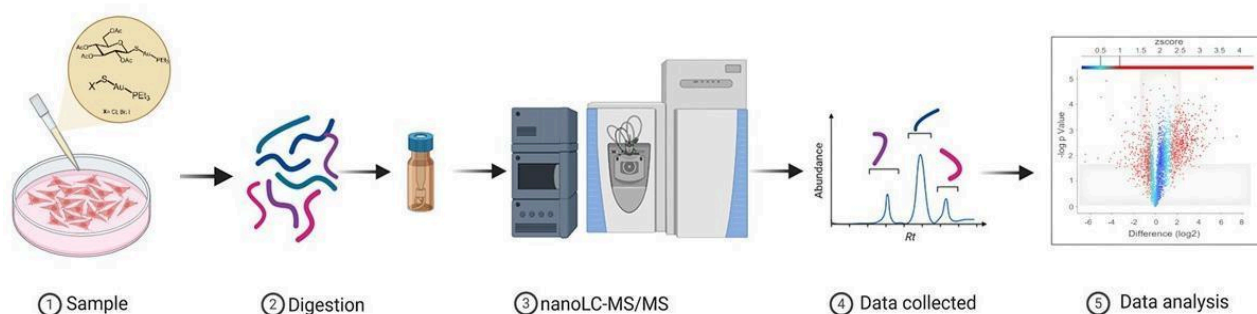

**Figure 1:** An overview on the MS-based proteomics analysis workflow

[1] G. Chiappetta, T. Gamberi, F. Faienza, X. Limaj, S. Rizza, L. Messori, G. Filomeni, A. Modesti, & J. Vinh, *Redox biology*, 52, (2022) 102294.

**Multifunctional flame retardant shape recovery epoxy nanocomposites containing carbon dots**

Immacolata Climaco,<sup>a</sup> Aurelio Bifulco,<sup>a</sup> Claudio Imperato,<sup>a</sup> Daniele Battezzore,<sup>b</sup> Michele Perrella,<sup>a</sup> Giuseppe Vitiello,<sup>a,c</sup> Giulio Malucelli<sup>b</sup> and Antonio Aronne,<sup>a</sup>

<sup>a</sup> *Department of Chemical, Materials and Production Engineering (DICMaPI), University of Naples Federico II, P.le Tecchio 80, 80125 Naples, Italy*

<sup>b</sup> *Department of Applied Science and Technology, Politecnico di Torino, Viale Teresa Michel 5, 15121 Alessandria, Italy*

<sup>c</sup> *CSGI, Center for Colloid and Surface Science, Via della Lastruccia 3, 50019 Sesto Fiorentino, Florence, Italy*

*E-mail: [immacolata.climaco@unina.it](mailto:immacolata.climaco@unina.it)*

Among thermosetting polymers, thanks to their good overall properties, epoxy resins (ERs) are employed in various industrial fields, such as packaging, paints, and coatings, where specific shape is required. The large application of ERs is responsible for the huge amount of waste deriving from these materials, which causes several concerns to our society in terms of pollution. The development of new strategies for the effective recycling of ERs is highly desirable, as more sustainable and low-cost approaches are needed to limit possible negative impacts on the environment. As the direct reuse of end-of-life (EoL) ERs would limit the production of related wastes, shape recovery epoxy systems may represent a valuable solution. The high flammability of ERs demands the exploitation of flame retardants (e.g., halogen- or phosphorus-based compounds), which are often still present in the waste, fostering the depletion of natural resources (e.g., P) and making even tougher the recycling of the EoL material [1]. In a view of sustainability and circular economy, carbon dots (CDs) can be obtained by the hydrothermal treatment of biowastes (e.g., humic acids) to synthesize high transparent epoxy nanocomposites (ENCs) with excellent fire and burn-through resistance. Herein, we synthesized new multifunctional ENCs, free of P and other additives, exhibiting photoluminescence, high hydrophobicity, fire resistance, and heat/flame-triggered shape recovery features [2]. Particularly, the shape recovery function can be triggered by various stimuli, including heat and flame. These all-in-one functionalities were conferred to ENCs through the addition of CDs at very low loadings (i.e., 0.1 and 0.3 wt.%).

[1] A. Bifulco, J. Chen, A. Sekar, W. Wu Klinger, A. Gooneie, S. Gaan, *J. Mater. Sci. Technol.* 199 (2024) 156-183.

[2] A. Bifulco, C. Imperato, I. Climaco, D. Battezzore, M. Perrella, G. Vitiello, A. Aronne, G. Malucelli, *Chem. Eng. J.* 484 (2024) 149327.

## Functional supramolecular polymers as artificial nucleases

Daniele Del Giudice, Riccardo Bellan, and Bert Meijer

*Institute for Complex Molecular Systems, Laboratory of Macromolecular and Organic Chemistry, Eindhoven University of Technology, 5600 MB Eindhoven, The Netherlands*

E-mail: [d.del.giudice@tue.nl](mailto:d.del.giudice@tue.nl)

Artificial supramolecular polymers (SPs) have proved to be attractive candidates to reproduce, at least in part, some of the features displayed by natural systems, such as self-organization, adaptation, evolution, and self-replication. To date, many efforts have been devoted to understanding supramolecular polymerization mechanisms, the underlying kinetics, and to unravel the relations between monomer structures and polymer properties [1]. Building on this fundamental knowledge, a plethora of SPs have been employed for the design of bio-inspired devices, systems and materials. They have also proved to be suitable as drug delivery systems, since they can either bind to hydrophobic or ionic guests, depending on monomer design. As an example, it has been shown that positively charged 1,3,5-benzenetricarboxamide (BTA) based SPs, can bind oligonucleotides in a superselective fashion due to the clustering of functional monomers and the resulting multivalency effect [2]. A less explored application of SPs, at least in aqueous solvents, is the possibility to use them as supramolecular catalysts. Taking inspiration from these previous findings, here we aim to develop hydrolytically active BTA-based SPs as artificial mimics of nucleases. To this end, we resorted to water soluble BTA monomers functionalized with the 1,4,7-triazacyclononane- $\text{Zn}^{2+}$  (TACN- $\text{Zn}^{2+}$ ) complex, well-known to catalyze the hydrolysis of phosphodiester bonds under mild conditions [3].

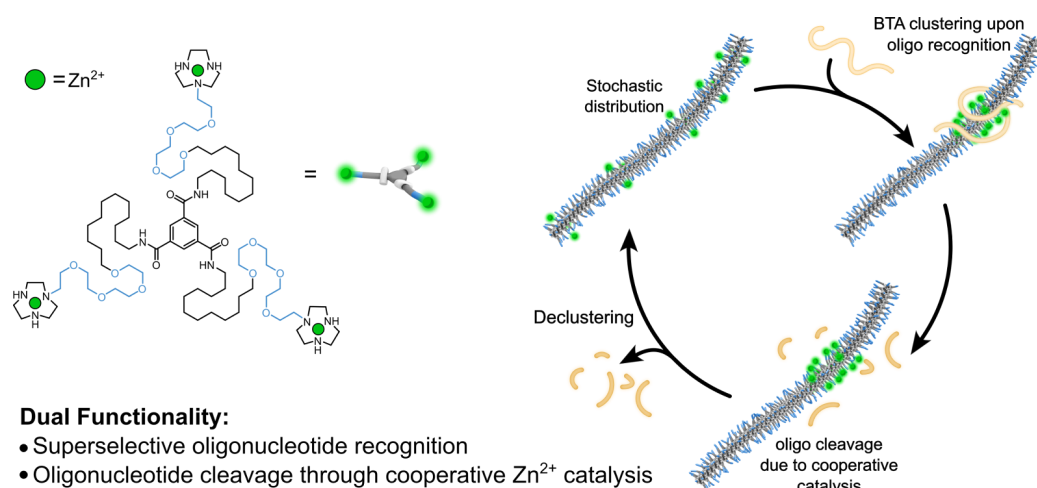

**Figure 1:** Molecular structure of (TACN- $\text{Zn}^{2+}$ ) functionalized BTA and envisaged mechanism for oligonucleotide cleavage.

[1] C. Kulkarni, E. W. Meijer, and A. R. A. Palmans, *Acc. Chem. Res.* 50 (2017) 1928–1936.

[2] L. Albertazzi, F. J. Martinez-Veracochea, C. M. A. Leenders, I. K. Voets, D. Frenkel, and E. W. Meijer *PNAS* 30 (2013) 12203–12208.

[3] D. Desbouis, I. P. Troitsky, M. J. Belousoff, L. Spiccia, and B. Graham, *Coord. Chem. Rev.* 256 (2012) 897–937.

## Synthesis and characterization of new Rh-phosphine carbonyl clusters

Giorgia Scorzoni,<sup>a,b</sup> Cristiana Cesari,<sup>a,b</sup> Cristina Femoni,<sup>a,b</sup> Maria Carmela Iapalucci,<sup>a</sup> and Stefano Zacchini<sup>a,b</sup>

<sup>a</sup> Department of Industrial Chemistry "Toso Montanari", University of Bologna, Via Piero Gobetti 85, 40129-Bologna, Italy

<sup>b</sup> Center for Chemical Catalysis "C<sup>3</sup>", University of Bologna, Bologna, Italy

E-mail: [giorgia.scorzoni3@unibo.it](mailto:giorgia.scorzoni3@unibo.it)

Rhodium is a transition metal known for its versatility in catalysing a range of reactions, and the addition of phosphine ligands can further enhance its reactivity and selectivity [1]. The phosphine-substituted  $\text{Rh}_4(\text{CO})_{12-x}\text{L}_x$  and  $\text{Rh}_6(\text{CO})_{16-x}\text{L}_x$  clusters have demonstrated catalytic abilities in various reactions, such as hydrogenation, hydroformylation, and carbonylation, owing to the synergistic effects of the ligands and the metal core [2].

Due to the lack in the literature, this work investigated the reactivity of  $\text{Rh}_4(\text{CO})_{12}$  as precursor in presence of different bidentate phosphines, performing the reactions under nitrogen atmosphere. New species of phosphine-substituted rhodium clusters have been characterised by IR,  $^{31}\text{P}$ -NMR and SC-XRD (Figure 1), and isolated with good selectivity and yield. When the aliphatic chain between the P atoms allowed it, dimeric species like  $\{\text{Rh}_4(\text{CO})_{10}(t\text{-dppe})\}_2$  and  $\{\text{Rh}_4(\text{CO})_{10}(\text{dpp-hexane})\}_2$  were obtained.

To verify the catalytic activity of these clusters, a few attempts of homogeneous hydrogenation were performed.

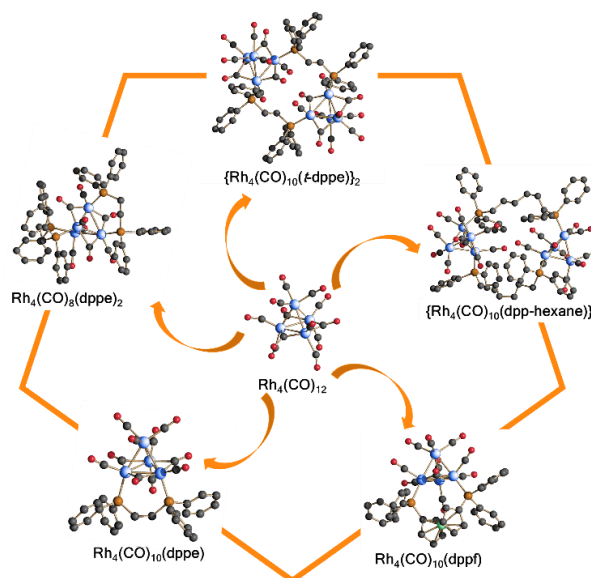

**Figure 1:** X-ray structures of new  $\text{Rh}_4(\text{CO})_{12-x}\text{L}_x$  species.

[1] C. Cesari, J.H. Shon, S. Zacchini, L.A. Berben, *Chem. Soc. Rev.* Ed. 50 (2021) 9503

[2] S.P. Tunik, I.O. Koshevoy, A.J. Poë, D.H. Farrar, E. Nordlander, M. Haukka, T.A. Pakkanen., *J. Chem. Soc. Dalton Trans.* (2003) 2457-2467

## Degradation reaction of *closo*-borohydrides, an XPS study

Ivan Dacrema,<sup>a,b</sup> Dominique Foix,<sup>c</sup> Fabrizio Murgia,<sup>a</sup> and Rémi Dedryvere<sup>c</sup>

<sup>a</sup> *Dipartimento di Scienze Chimiche, Fisiche, Matematiche e Naturali, Università degli Studi di Sassari, Via Vienna 2, 07100-Sassari, Italy*

<sup>b</sup> *Department of Materials Chemistry, National Institute of Chemistry, Hajdrihova 19, 1000-Ljubljana, Slovenia*

<sup>c</sup> *IPREM, Université de Pau, Hélioparc Pau Pyrénées, 2 av. Pierre Angot, 64000-Pau, France*

*E-mail : ivan.dacrema@ki.si*

Thanks to their high ionic conductivity, electrochemical stability and compatibility with alkali metal anodes, borohydrides are expected to be one of the main electrolyte materials for next-generation all-solid-state batteries. An in-depth understanding of the chemistry happening at the reactive electrode-electrolyte interface is needed to close the gap towards commercially viable devices. This work aims at tackling this objective by probing the structural characterisation of different types of *closo*-borohydride-based ionic conductors.

The surface chemistry of different types of *closo*- and (carba)*closo*-borohydrides, both as received and after mechanical treatment, has been investigated by means of X-ray photoelectron spectroscopy (XPS) to understand the possible degradation reactions taking place. The analysis showed a progressive shift of the boron signal to lower binding energies, consolidating the previous assumption of dehydrogenation yet reported by our group [1], while the carbon signal showed the progressive formation of an unusual low binding energy component, suggesting the formation of a carbon species with an electron-rich environment attributed to a similar dimer species previously reported in literature [2].

This work lays the foundations for further XPS analysis on this class of compounds by establishing a set of reference data that will prove useful for future insights into their surface chemistry. In particular, this work will aim to unveil the electrolyte's degradation mechanism after electrochemical cycling, by working above the safe voltage to induce degradation. This will, in the end, guide the synthesis of new even safer and more robust materials.

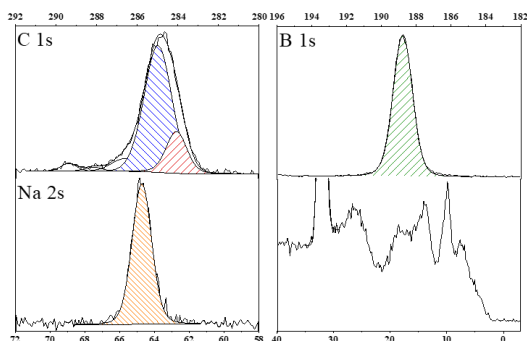

**Figure 1:** C 1s, B 1s, Na 2s and valence XPS spectra of the pristine compound.

[1] F. Murgia, M. Brighi, L. Piveteau, C. E. Avalos, V. Gulino, M. C. Nierstenhöfer, P. Ngene, P. de Jongh, and R. Černý, *ACS Applied Materials & Interfaces* 13 (2021) 61346-61356

[2] R. J. Wiersema and R. L. Middaugh, *Journal of the American Chemical Society* (1967) 5078.

## Light responsive transparent wood as promising material for sustainable building integrated devices

Federico Casti<sup>a</sup>, Gaia Venusti<sup>b</sup>, Daniele Nuvoli<sup>b</sup>, Alberto Mariani<sup>b</sup>, Giuseppe Sforzini<sup>a</sup>

<sup>a</sup>Department of Chemical and Geological Sciences, University of Cagliari, S.S. 554 bivio per Sestu, 09042 Monserrato (CA), Italy

<sup>b</sup> Department of Chemical, Physical, Mathematical, and Natural Sciences, University of Sassari, Via Vienna, 2, 07100 Sassari (SS), Italy

E-mail: federico.casti@unica.it

Glassy transparent materials are highly appealing for the development of energy-saving building [1]. However, these materials have some limitations, such as heavy weight, brittleness, and high production costs. A possible solution to these problems is transparent wood (TW), which is light weight, robust, cheap, and in addition offers UV blocking and low thermal conductivity [2]. These characteristics can contribute to reducing the energy consumption of buildings and the carbon footprint of the construction industry. TW can be made in a two-step process: an initial delignification, to empty the channels (*lumens*) of pre-existing lignin-derived chromophores, using an oxidant solution [3]. The second step involves the infiltration into the *lumens* of resins with a refractive index that matches to that of delignified wood. In this work, we report a novel transparent wood with enhanced optical properties. The wood consists of dedicated chromophores, such as triaryl amines and azobenzenes, introduced by adsorption together with the polymer. The functionalized TW was prepared with various concentrations of chromophores in the presence of methacrylates as polymer filler. The composite's optical properties were investigated using different techniques. The introduction of chromophores introduces optical features such as colouring and photochromic behaviour.

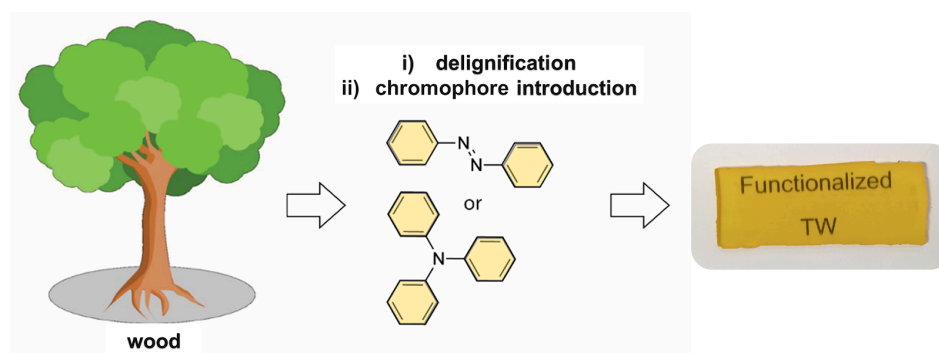

**Figure 1:** Light responsive TW fabrication process.

[1] L. Hu, et al. *Adv. Energy Mater.*, 2016, 6, 1601122

[2] L. Berglund, et al. *ACS Sustain. Chem. Eng.*, 2019, 7, 6061–6067.

[3] L. A. Berglund, et al. *ACS Appl. Mater. Interfaces*, 2019, 11, 20465–20472

**New insight on electrochemistry: PIMs as groundbreaking binding agents for a new era of energy applications**

Eugenio De Nardo<sup>a</sup>, Carmela Astorino<sup>a</sup>, Valentina Bugliarelli<sup>a</sup>, Marco Etzi<sup>b</sup>, Stefania Lettieri<sup>a</sup>, Giuseppe Ferraro<sup>a</sup>, Mattia Bartoli<sup>b</sup>, Sergio Bocchini<sup>a,b</sup>

<sup>a</sup> *Department of Applied Science and Technology, Politecnico di Torino, Corso Duca degli Abruzzi 24, 10129, Italy*

<sup>b</sup> *Center for Sustainable Future Technologies, Istituto Italiano di Tecnologia, Via Livorno 60, 10144, Italy*

*E-mail: [eugenio.denardo@polito.it](mailto:eugenio.denardo@polito.it)*

The rapid development of renewable energy sources, such as wind and solar power, bursts the demand for storage, thus electrochemical energy conversion technologies. These technologies are essential for balancing intermittent energy supply and stabilizing the power grid. Several electrochemical processes, including redox flow batteries, water and CO<sub>2</sub> electrolyzers, supercapacitors, batteries, and fuel cells hold great promise for large-scale renewable energy conversion and storage [1]. In these technologies, binders play a crucial role in ensuring mechanical stability and efficient transport of reactants, ions and products at the catalyst surface.

Perfluorosulfonic acids (PFSA) like Nafion® are extensively employed due to their remarkable chemical properties. These materials are invaluable as binders in electrochemistry. However, PFSA, like many other fluorine-containing materials, raise significant environmental concerns, both in terms of their manufacture and disposal. This creates an urgent need for more environmentally friendly yet equally effective alternatives [2]. To date, ionomeric Polymers of Intrinsic Microporosity (PIMs) used in electrochemistry have shown considerable potential [3].

PIMs are characterized by a rigid backbone structure, which prevents efficient packing and creates micropores. As a result of their structure, PIMs have first emerged as materials for gas separation, as their intrinsic micropores provide a large empty volume fraction. These empty voids, combined with molecular tuning, facilitate a selective molecular sieve effect, allowing only specific molecules to permeate. The distinct advantages offered by PIMs, such as chemical stability and enhanced gas permeability are crucial for a binder in electrochemical devices, allowing efficient transport of reactants to active sites within the catalyst layers, and significantly improving device efficiency and reaction rates. We propose a functionalized PIM designed as ionomeric binder for electrochemical applications. This PIM has shown promising results and offers a sustainable alternative that could reshape the future of electrochemical technologies and play a significant role in a low-carbon economy.

[1] P. Zuo, Y. Li, A. Wang, R. Tan, Y. Liu, X. Liang, F. Sheng, G. Tang, L. Ge, L. Wu, Q. Song, N. B. McKeown, Z. Yang, and T. Xu, *Angew. Chem. Int. Ed.* 59 (2020) 9564–9573

[2] W. Liu, J. Wu, W. He, and F. Xu, *Ecosyst Health Sustain.* 5 (2019) 1-19

[3] N. B. McKeown, *Polymer* 202 (2020) 122736

## Polymerisable ligands: the route to phosphorescent Ir(III)-based metallapolymers

Eleonora Previati,<sup>a</sup> Giulia Vigarani,<sup>b</sup> Valentina Fiorini,<sup>b</sup> Massimiliano Massi,<sup>c</sup> Andrea Pucci,<sup>d</sup> Loris Giorgini,<sup>b</sup> and Stefano Stagni<sup>b</sup>

<sup>a</sup> Department of Applied Science and Technology, Politecnico di Torino, Corso Duca degli Abruzzi 24, 10129-Torino, Italy

<sup>b</sup> Department of Industrial Chemistry "Toso Montanari", University of Bologna, Via Piero Gobetti, 85, 40129-Bologna, Italy

<sup>c</sup> Department of Chemistry, Curtin University, Kent Street, 6102-Bentley WA, Australia

<sup>d</sup> Department of Chemistry and Industrial Chemistry, University of Pisa, Via Giuseppe Moruzzi, 13, 56124-Pisa, Italy

E-mail: [eleonora.previati@polito.it](mailto:eleonora.previati@polito.it)

Phosphorescent metallapolymers have recently gained great interest due to the possibility of endowing polymers with the bright and color tunable emission typical of Ir(III) cyclometalates with general formula  $[\text{Ir}(\text{C}^{\wedge}\text{N})_2(\text{N}^{\wedge}\text{N})]^{0/+}$ . In this context, after a preliminary study of phosphorescent Luminescent Solar Concentrators obtained by physical dispersion of Ir(III) complexes into different acrylic matrices [1], a new set of "polymerizable ligands" capable of coordinating the metal center and, at the same time, being able to copolymerize with methacrylic monomers was designed. To this aim/purpose, four well-known diimine ligands (N<sup>^</sup>N) [2,3] were equipped with a polymerizable styryl unit. Then, metallapolymers were obtained either by the complexation of a pre-formed MMA-L copolymer with different amounts of appropriate Ir fragments, or by the copolymerization of the mononuclear Ir(III) complexes with MMA. The new hybrid materials displayed intense phosphorescence in the solid state, with high PLQY and Ir(III)-centred emission colors spanning from blue to orange, paving the way for the application of this new class of metallapolymers in the Luminescent Solar Concentrators (LSCs) technology.

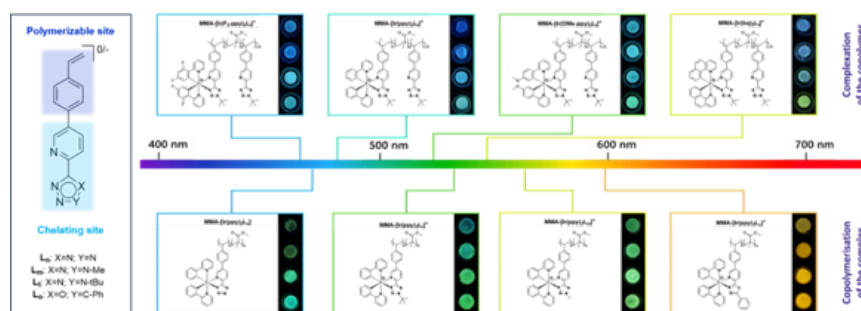

**Figure 1:** General structure of the polymerizable ligands; materials structures and appearance under UV light.

[1] V. Fiorini, N. Monti, G. Vigarani, G. Santi, F. Fasulo, M. Massi, L. Giorgini, A. B. Muñoz-García, M. Pavone, A. Pucci, and S. Stagni, *Dyes and Pigments* 193 (2021) 109532-109543

[2] S. Stagni, S. Colella, A. Palazzi, G. Valenti, S. Zacchini, F. Paolucci, M. Marcaccio, R. Q. Albuquerque, and L. De Cola, *Inorg.Chem.* 47 (2008) 10509-10521

[3] J. Zhang, L. Zhou, H. A. Al-Attar, K. Shao, L. Wang, D. Zhu, Z. Su, M. R. Bryce, and A. P. Monkman, *Adv. Funct. Mater.* 23 (2013) 4667–4677.

## Electroluminescent copper(I) complexes for lighting applications

Chiara Reviglio,<sup>a</sup> Luca M. Cavinato,<sup>b</sup> Claudia Barolo,<sup>a</sup> Rubén D. Costa,<sup>b</sup> and Claudio Garino<sup>a</sup>

<sup>a</sup> *Dipartimento di Chimica, Università degli Studi di Torino, Via Giuria 7, 10125-Torino, Italy*

<sup>b</sup> *Functional Materials, Tech. University of Munich, Schulgasse 22, 94315-Straubing, Germany*

E-mail: [chiara.reviglio@unito.it](mailto:chiara.reviglio@unito.it)

The large availability of copper in the Earth's crust has led in the last years to the increasing interest into electroluminescent copper(I) coordination compounds in the field of solid state lighting, in both OLEDs (Organic Light-Emitting Diodes) and LECs (LightEmitting Electrochemical Cells), particularly in substitution of electroluminescent materials based on rare and expensive second and third-row transition metals [1].

An interesting feature of copper(I) complexes is their possibility to show the so-called Thermally Activated Delayed Fluorescence (TADF), which allows to reach high efficiencies of emission thanks to the possibility of intersystem crossing (ISC) and reverse intersystem crossing (RISC) to occur even in the absence of a heavy metal [2].

Herein we present the synthesis of a series of tetrahedral heteroleptic  $[\text{Cu}(\text{P}^{\wedge}\text{P})(\text{N}^{\wedge}\text{N})]^+$  compounds, containing the Xanthphos as the  $\text{P}^{\wedge}\text{P}$  ligand and differently substituted pyridine pyrazoles as the  $\text{N}^{\wedge}\text{N}$  ligand (Figure 1), designed in order to be applied in the active layer of LECs. The choice of ligands containing a 5-membered N-heterocycle, instead of common bipyridines and phenanthrolines, is aimed at the expansion of the colour range of emission towards the green-blue part of the visible spectrum [2,3]. The synthesized compounds have been characterized structurally, using NMR and XRD techniques, and electronically, using UV-Vis spectroscopies (Figure 1) and cyclic voltammetry. The most promising compounds of the series have also been incorporated and tested in prototypal devices.

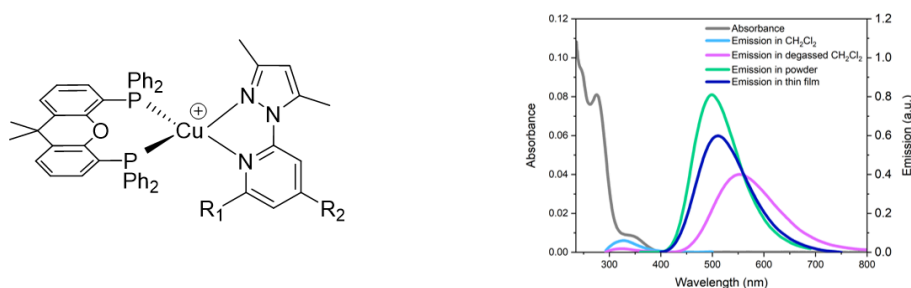

**Figure 1:** Chemical structure and photophysical properties of synthesized complexes.

[1] G.U. Mahoro, J. Fernandez-Cestau, J. L. Renaud, P. B. Coto, R. D. Costa, and S. Gaillard, *Adv. Opt. Mater.* 8 (2020) 2000260

[2] C. E. Housecroft, and E. C. Constable, *J. Mater. Chem. C* 10 (2022) 4456-4482

[3] L. M. Cavinato, S. Wölfl, A. Pöthig, E. Fresta, C. Garino, J. Fernandez-Cestau, C. Barolo, and R. D. Costa, *Adv. Mater.* 34 (2022) 2109228

## Coordination polymers as high-performing counter-electrodes for DSSCs

Marcello Franzini,<sup>a\*</sup> Simone Galliano,<sup>a</sup> Matteo Bonomo,<sup>a</sup> Kezia Sasitharan,<sup>b</sup> George Harvey Morritt,<sup>b</sup> Marina Freitag,<sup>b</sup> Andrea Reale,<sup>c</sup> Gianluca Filiddani,<sup>d</sup> Marco Borri,<sup>d</sup> and Claudia Barolo.<sup>a</sup>

<sup>a</sup> Department of Chemistry and NIS Interdepartmental Centre and INSTM. University of Turin, Reference Centre, Via Gioacchino Quarello 15A, Turin 10135, Italy;

<sup>b</sup> School of Natural and Environmental Science, Newcastle University, Newcastle upon Tyne, NE1 4LB, UK.

<sup>c</sup> Department of Electronic Engineering, University of Rome Tor Vergata-CHOSE, Via del Politecnico 1, 00133 Rome, Italy;

<sup>d</sup> Martur Italy srl, Via Stefano Scoffone 3/5, Grugliasco 10095, Turin, Italy.

\* [marcello.franzini@unito.it](mailto:marcello.franzini@unito.it)

While silicon-based photovoltaic technology currently dominates the market, it faces limitations such as raw material availability and reduced efficiency under low/diffuse light. A promising alternative is Dye-sensitized solar cells (DSSCs) offering several advantages like low cost and ease of fabrication with greater versatility (i.e. flexibility, transparency). The composition and functionality of DSSCs involve a photoelectrochemical reaction facilitated by a photoanode, dye, electrolyte redox couple, and counter-electrode (CE). The most performing CEs are restricted to Platinum, PEDOT, and carbon-based systems, but they suffer from scarcity, high costs, and low stability [1]. Increasing the variety of CEs would be fundamental to enhancing the photovoltaic performance of DSSCs and allowing innovative redox couples and dyes. In this contribution, a series of metal-sulfur coordination polymers have been synthesized, characterized and successfully adopted as counter-electrodes for DSSCs [2]. Organometallic polymer CEs have been studied in combination with different electrolytes based on copper, cobalt and iodine showing encouraging results with photovoltaic efficiencies close to 10% and comparable to standard Pt and PEDOT CEs.

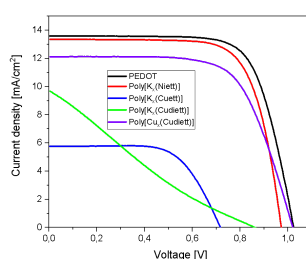

**Figure 1:** J-V curves of DSSCs based on PEDOT and organometallic polymers.

Authors acknowledges support from the Project CH4.0 under the MUR program "Dipartimenti di Eccellenza 2023-2027" (CUP: D13C22003520001). M.Franzini acknowledges the support of Martur Italy srl.

[1] S. Ding, J. Yuan, Li Huijin, X. Yuan, and M. Li, *RSC Advances* 13 (2023) 12309

[2] A.K. Menon, R.M.W. Wolfe, S. Kommandur, S.K. Yee, *Adv. Electron. Mater.* 5 (2019) 1800884

## Colorless And Transparent Dye Sensitized Solar Cells Based On NIR Dyes And Transparent Electrolytes

Donato Pasculli<sup>a</sup>, Luca Morandini<sup>a</sup>, Ana Y. Segura Zarate<sup>a</sup>, Simone Galliano<sup>b</sup>, Maksym Bokan<sup>a</sup>, Matteo Bonomo<sup>a</sup>, Nadia Barbero<sup>a</sup>, Raffaele Borrelli<sup>b</sup>, Fabio Matteocci<sup>d</sup>, Aldo Di Carlo<sup>d</sup>, Frederic Sauvage<sup>c</sup>, Claudia Barolo<sup>a</sup>

<sup>a</sup>*Dipartimento di Chimica, NIS Interdepartmental and INSTM Reference Centre, Università degli Studi di Torino, Via Pietro Giuria 7, 10125, Torino, Italia.*

<sup>b</sup>*Dipartimento di Scienze Agrarie Forestali e Alimentari, Università degli Studi di Torino, Largo Paolo Braccini 2 - 10095 Grugliasco, Torino, Italia.*

<sup>c</sup>*CNRS, UPJV, Université Picardie Jules Verne, LRCS, UMR 7314, Amiens, France.*

<sup>d</sup>*CHOSE- Centre for Hybrid and Organic Solar Energy, Department of Electronics Engineering, University of Rome "Tor Vergata", Via del Politecnico 1- 00133 Roma, Italia.*

E-mail: [donato.pasculli@unito.it](mailto:donato.pasculli@unito.it)

The development of integrated PV in windows/facades on buildings takes us deeper in different aspects like aesthetics, stability and performance. With this technology, it is possible to offer a sustainable option for transparent and colourless windows, due to their versatility in the selection of dyes [1,2]. Our group synthesised some polymethine dyes as photosensitizers in a wavelength-selective NIR-DSSC [3] by using microwave heating, saving time and money in the process. Until now, some different chromophores have been tested in DSSCs. Another key component of these devices is represented by the redox couple, in fact it must be colourless and has to match the energetic levels of the NIR dye. Due to the joint efforts of different research groups within the IMPRESSIVE project, fully transparent and colourless DSSC were built reaching 80 % transmittance in complete devices [2]. The project results were the starting point of the new CANVAS project, whose aim is to create a library of NIR dyes and a series of colourless electrolytes in order to increase both the device's efficiency and stability without losing transparency.

[1] F. Grifoni, M. Bonomo, W. Naim, N. Barbero, T. Alnasser, I. Dzeba, M. Giordano, A. Tsaturyan, M. Urbani, T. Torres, C. Barolo, and F. Sauvage, *Adv. Energy Mat.* 11 (2021) 2101598.

[2] W. Naim, V. Novelli, I. Nikolinakos, N. Barbero, I. Dzeba, F. Grifoni, Y. Ren, T. Alnasser, A. Velardo, R. Borrelli, S. Haacke, S. M. Zakeeruddin, M. Graetzel, C. Barolo, and F. Sauvage, *JACS Au* 1 (2021) 409-426.

[3] D. Saccone, S. Galliano, N. Barbero, P. Quagliotto, G. Viscardi, and C. Barolo, *Europ. J. Org. Chem.* (2016) 2244–2259.

This study is a result of the research project “nuovi Concetti, mAteriali e tecnologie per l'iNtegrazione del fotoVoltAico negli edifici in uno scenario di generazione diffuSa” [CANVAS], funded by the Italian Ministry of the Environment and the Energy Security, through the Research Fund for the Italian Electrical System (type-A call, published on G.U.R.I. n. 192 on 18-08-2022). This project has received funding from the EU's Horizon 2020 research and innovation program (G.A. n° 826013).

## **Novel Phenothiazine-modified PTAA Hole Transporting Materials for flexible Perovskite Solar Cells: a trade-off between performance and eco-friendliness**

Daniel Augusto Machado Alencar<sup>a</sup>, Giulio Koch<sup>b</sup>, Francesca De Rossi<sup>b</sup>, Amanda Generosi<sup>c</sup>, Giuseppe Ferraro<sup>a</sup>, Matteo Bonomo<sup>a</sup>, Samyuktha Noola<sup>a</sup>, Giulia Pellis<sup>a</sup>, Pierluigi Quagliotto<sup>a</sup>, Barbara Paci<sup>c</sup>, Francesca Brunetti<sup>b</sup>, Claudia Barolo<sup>a,d,e</sup>

<sup>a</sup> Department of Chemistry, NIS and INSTM Reference Centre, Università degli Studi di Torino, via Pietro Giuria 7, 10125, Italy, Torino

<sup>b</sup> CHOSE – Centre for Hybrid and Organic Solar Energy, Department of Electronic Engineering, University of Rome “Tor Vergata”, via del Politecnico 1, Rome, 00133 Italy

<sup>c</sup> SpecX-Lab, ISM-CNR, Via del Fosso del Cavaliere 100, 00133 Roma, Italy

<sup>d</sup> ICxT Interdepartmental Centre, University of Turin, Lungo Dora Siena 100, 10153, Torino, Italy

<sup>e</sup> Istituto di Scienza, Tecnologia e Sostenibilità per lo sviluppo dei Materiali Ceramici (ISSMC-CNR), Via Granarolo 64, 48018, Faenza, RA, Italy

Email: [danielaugusto.machadodealencar@unito.it](mailto:danielaugusto.machadodealencar@unito.it)

Flexible Perovskite Solar Cells (f-PSC) is a rapidly growing niche market within the PSC field, finding an optimal use for wide range of photovoltaics applications, (e.g. Indoor Photovoltaics, Space Applications, Wearable Electronics), due to their higher power-to-weight ratio [1]. However, key issues still oppose the industrial feasibility and acceptability of f-PSC, such as the overall sustainability of the device; this can be improved by working on the device layers, among which, Hole Transport Materials (HTMs) can play a major role. Two major concerns associated with HTM hinder the sustainable upscaling of f-PSC: (i) waste generation from inefficient synthetic protocols and (ii) the deposition process employing toxic and hazardous materials. Both of these aspects translate to high production costs. Herein, we report four novel PTAA-based polymeric HTMS that can be solution processable using an alternative, environmentally-friendlier solvent (THF) to the ones that are conventionally used (Toluene or Chlorobenzene) [2]. The successful application and even outperformance of one of the polymers with respect to PTAA, has inspired us to pursue alternative methods that employ greener synthetic pathways for the production of said polymers. We confidently expect that our redesign-ed HTM structures and their development will ensure a massive reduction of production cost and waste generated, allowing us to create one of the first, true green “cradle-to-gate” organic polymeric HTM.

This work acknowledges support from Project CH4.0 under the MUR program “Dipartimenti di Eccellenza 2023-2027” (CUP:D13C22003520001) and Spot-IT project that was funded by the CETPartnership, the Clean and Energy Transition Partnership under the 2022 CETPartnership joint call for research proposal.

[1] S. Mishra, S. Ghosh, and T. Singh, *ChemSusChem* (2021) 512-538

[2] M. Zhang, D. Xin, X. Zheng, Q. Chen, and W.H. Zhang, *ACS Sustain. Chem. Eng.* 8 (2020) 35 13126-13138

### **Sustainable photochemistry: investigation of green media to enhance the TTA-UC efficiency**

Giulia Quaglia, and Loredana Latterini

*Dipartimento di Chimica, Biologia e Biotecnologie, Nano4Light Lab, Università degli Studi di Perugia, Via Elce di Sotto 8, 06123-Perugia, Italy*

*E-mail: [giulia.quaglia@unipg.it](mailto:giulia.quaglia@unipg.it)*

Solvents can strongly affect the energy and dynamics of electronic excited states, thus altering their deactivation paths and the efficiencies of photoinduced processes. For this reason, most of the photosensitization experiments are still based on traditional media, which do not meet the green chemistry criteria.

In this work, radiation up-conversion based on triplet-triplet annihilation (TTA-UC) is considered as test, since it involves bimolecular energy transfer processes among different species; requires anaerobic environments to avoid triplet-state quenching by the dissolved oxygen molecules and it is diffusion controlled; therefore, the environment surrounding the chromophores plays a crucial role.

TTA-UC is a complex non-linear photophysical process in which two organic molecules, acting as electromagnetic sensitizer (here, a platinum porphyrin, PtOEP) and emitter of upconverted radiation (pyrene and anthracene derivatives), are involved. PtOEP successfully absorbs green light (535 nm) and, through an efficient intersystem crossing (ISC) process, populates its triplet excited state ( $3S^*$ ). In the presence of emitter, triplet-triplet energy transfer occurs through a Dexter type mechanism, forming a triplet excited state ( $3E^*$ ). When high concentrations of  $3E^*$  are locally formed, they can undergo exchange energy transfer processes, resulting in a triplet-triplet annihilation phenomenon (TTA). TTA leads to an emitter molecule in the singlet excited state ( $1E^*$ ), from which fluorescence occurs, leading to the blue up-converted emission.

Up to now, many efforts have been done to find the right chromophores pairs to maximize efficiencies, but limited attentions have been given to the nature of the media.

In this contribution, for the first time, a wide range of green solvents (alcohols, esters, carbonates, ketones, aromatics, ethers, dipolar aprotic and fatty acids) have been tested. The results obtained demonstrate that several green solvents can be valuable options to replace toxic counterparts, allowing efficient energy transfer processes resulting in TTA-UC with quantum yields comparable or higher than in traditional solvent [1].

Moreover, to design and process materials for future real applications, we propose eco-friendly oil-in-silica up-converting nanocapsules. The product is a robust solid-like material able to generate blue up-converted emission in air-equilibrated and harsh environments using incoherent low-power excitation [2].

[1] G. Quaglia, F. Campana, L. Latterini, and L. Vaccaro, *ACS Sustain. Chem. Eng.* 10 (2022) 9123–9130.

[2] G. Quaglia, B. Bartolomei, P.L. Gentili, and L. Latterini, *J. Mater. Chem. C* 10 (2022) 9073-9080.

**Sunlight-driven photocatalytic H<sub>2</sub> production from biomass by sustainable TiO<sub>2</sub>/magnetic zeolite composites**

Valentina Quarta,<sup>a</sup> Matteo Nicolini,<sup>b</sup> Stefano Alberti,<sup>b</sup> Maurizio Ferretti,<sup>b</sup> Antonella Profumo,<sup>a</sup> and Andrea Speltini<sup>a</sup>

<sup>a</sup>*Department of Chemistry, University of Pavia, Via Taramelli 12, 27100-Pavia, Italy*

<sup>b</sup>*Department of Chemistry and Industrial Chemistry, University of Genova, Via Dodecaneso 31, 16146-Genova, Italy*

E-mail: [valentina.quarta02@universitadipavia.it](mailto:valentina.quarta02@universitadipavia.it)

The development of renewable energy has been the aim of extensive research so far, and solar energy is considered a promising candidate due to the increasing energy demand in the modern society [1]. Fossil fuels present various drawbacks like environmental pollution and CO<sub>2</sub> emission, while H<sub>2</sub> is a viable alternative to these energy sources. In this regard, its production based on solar radiation has become increasingly attractive as a cost-effective and environmentally friendly option [2].

The use of TiO<sub>2</sub> as catalyst and Pt as co-catalyst for H<sub>2</sub> production from water under UV-vis radiation is well established. In this work, to achieve a more sustainable production, TiO<sub>2</sub>-based photocatalysts supported on magnetic materials derived from wastes have been tested for lab-scale photocatalytic H<sub>2</sub> evolution. These photocatalysts are composites obtained by hydrothermal treatment (150°C – 3 h) containing TiO<sub>2</sub> and magnetic zeolites prepared from commercial reagents (called FF1) or waste biomass such as rice husk ash as silica source (called C4SC). Composites prepared with different TiO<sub>2</sub>/zeolite ratios (1:2 w/w, 1:1 w/w and 1:0.5 w/w, respectively) were investigated in the preliminary photocatalytic tests in presence of glucose (0.1 M) as probe biomass-derived sacrificial agent, and Pt as the conventional co-catalyst (0.5 wt%). After irradiation under simulated solar light (500 W/m<sup>2</sup>, 4 h), the headspace gas collected in the photoreactor was determined by gas chromatography coupled with thermal conductivity detector, and the results reported in terms of HER (hydrogen evolution rate) as μmoles of H<sub>2</sub> per gram of catalyst per hour (μmol g<sup>-1</sup> h<sup>-1</sup>). The best result was achieved by the (1:0.5 w/w) TiO<sub>2</sub>:C4SC composite, with an average HER of about 300 μmol g<sup>-1</sup> h<sup>-1</sup> (inter-batch RSD <15%, n=3). These findings prove the good performance of the TiO<sub>2</sub> fraction in the composite compared to neat TiO<sub>2</sub> that provided around 500 μmol g<sup>-1</sup> h<sup>-1</sup> (inter-batch RSD <15%, n=3). At the same time, these are promising results as the photocatalyst is obtained by a sustainable preparation route, and can be easily recovered through magnetic separation.

To further improve the sustainability of the process and, possibly, to increase the absorption of TiO<sub>2</sub> in the visible range, carbon dots will be considered. To this aim, their hydrothermal synthesis starting from agri-food (waste)biomass is under study evaluating different experimental factors such as time and temperature.

[1] P. Gao, Y. Zhang, M. Wang, W. Yu, Z. Yan, and J. Li, *J. Mat. Sci. Technol.* 211 (2025) 134–144

[2] D. Badrinarayanan, S. Bokkassam, and J. Krishnan, *Energy Rep.* 12 (2024) 920–941



---

## Flash presentations

- FL001- ERRICHELLO Giulia (UniPD)
- FL002- BALDASSIN Davide (UniVE)
- FL003 - INICO Elisabetta (UniMiB)
- FL004 - TOMMASI Matteo (UniMI)
- FL005 - ITRI Giulia Maria (UniRC)
- FL006 - TRIMBOLI Antonio Cosimo Pio (UniRC)
- FL007 - FERRARO Giorgia (UniVE)
- FL008 - BERTOCCHI Francesco (UniPR)
- FL009 - MAGNAGHI Lisa Rita (UniPV)
- FL010 - LAFACE Zoe (UniMI)
- FL011 - NICCHIO Luca (UniPV)
- FL012 - VENDITTI Jacopo (UniSI)
- FL013 - CASSANO Lorenza (UniPV)
- FL014 - VILLAMIL Valentina (UniMore)
- FL015 - MILLI Giorgio (UniPV)
- FL016 - SODANO Federica (UniNA)
- FL017 - COLLEONI Alessio (UniMI)
- FL018 - BILLI Chiara (UniNA)
- FL019 - BALDI Andrea (UniFI)
- FL020 - BOTTER Eleonora (UniVE)
- FL021 - JIRITANO Antonio (UniCAL)
- FL022 - VIADA Gabriele (UniTO)
- FL023 - BRESSI Viviana (UniRC)
- FL024 - MANCARELLA Federica (UniSA)
- FL025 - CAROTTI Chiara (PoliMI)
- FL026 - CARCAGNI Martina (PoliBA)
- FL027 - NEBBIOSO Viviana (UniNA)
- FL028 - MOUSAVI Mohammad Sadeq (UniSA)
- FL029 - D'ANNA Luisa (UniPa)
- FL030 - GUEMBE-GARCÍA Marta (UBU)
- FL031 - MACCARI Chiara (UNIPR)
- FL032 - DUCOLI Serena (UniBS)

---

FL033 - GRAMEGNA ALICE (INSTM)  
FL034 - SALERNO Giorgia (UniMIB)  
FL035 - PAGANO Giorgio (UniRoma2)  
FL036 - CORNALE Michela (UniRoma2)  
FL037 - D'AURIA Martina (UniNA)  
FL038 - BUSTO Francesco (UniBA)  
FL039 - FABBIAN Simone (UniPD)  
FL040 - SODINI Andrea (UniFI)  
FL041 - BRIOSCHI Giulia (UniMI)  
FL042 - FOSSATI Alice (UniPV)  
FL043 - KASSOUF Nicholas (UNIBO)  
FL044 - PAVONE Sara (UniFI)  
FL045 - SCAPPATICCI Claudia (UnivAQ)  
FL046 - TUMMINELLI Elisabetta (UniPv)  
FL047 - NARDI Alberto (UniTO)  
FL048 - ALAMIA Federica (UniPA)  
FL049 - BATTISEGOLA Chiara (UniNA)  
FL050 - FAVA Marianna (UniSI)  
FL051 - BONO Alessia(UniPA)  
FL052 - FASSI Enrico Mario Alessandro (UniMI)  
FL053 - LOMBARDO Lisa (UniME)  
FL054 - MOLARO Maria Cristina (UniNA)  
FL055 - MERINGOLO Federica (UniCAL)  
FL056 - ARNAIZ Ana (UniBU)  
FL057 - BASSO Francesca (IIT, UniGE)  
FL058 - FREZZA Chiara (UniROMA3)  
FL059 - CAZZOLA Sara (UniPD)  
FL060 - LIOTINO Stefano (UniBA)  
FL061 - CAPPELLETTI David (UniPD)  
FL062 - ASTORINO Carmela (PoliTO)  
FL063 - MALTONI Pierfrancesco (UniGE)

## Design of polyoxometalate coacervate-based photocatalytic microreactors for artificial photosynthesis

Giulia Errichiello,<sup>a,b</sup> Thomas Gobbato,<sup>b</sup> Daniele Rosa-Gastaldo,<sup>a</sup> Francesco Rigodanza,<sup>a</sup> and Marcella Bonchio<sup>a,b</sup>

<sup>a</sup> Department of Chemical Sciences, Università degli studi di Padova, Via Marzolo 1, Padova, Italy

<sup>b</sup> INSTM, Via Giuseppe Giusti, 9, 50121 Firenze, Italy

E-mail: [giulia.errichiello@unipd.it](mailto:giulia.errichiello@unipd.it)

Pushing the boundaries of solar fuel research, wireless artificial photosynthetic systems are being designed to mimic Nature's way. These devices envision a machinery that harnesses sunlight to transform readily available resources like water and carbon dioxide into valuable products like H<sub>2</sub>, carbon derivatives, and O<sub>2</sub>. Unlike existing methods, this innovative technology is designed to operate without an external electrical input or complex circuits. Such bio-inspired molecule-based systems require four key elements: a photosensitizer, a catalyst, an electron shuttle, and a vesicle acting as a nano-reactor. PLANKT-ON project (EIC Pathfinder Open 2022) inserts in this scenario, proposing polyoxometalate membranized coacervate vesicles (PCVs) as micro-compartmentalized protocells for artificial photosynthesis [1]. Photocatalytic active units named artificial quantasomes (QS) are encapsulated in the vesicle, emulating the Photosystem II (PSII). The supramolecular structure of QS self-assembles spontaneously in water, due to the complementary electrostatic interactions between bis-cationic perylene bisimide derivatives, acting as light-harvesting antennae, and a deca-anionic polyoxometalate ruthenium-based water-splitting catalyst [2,3]. This work presents our research on designing and characterizing these building blocks to achieve light-induced water oxidation within a confined environment.

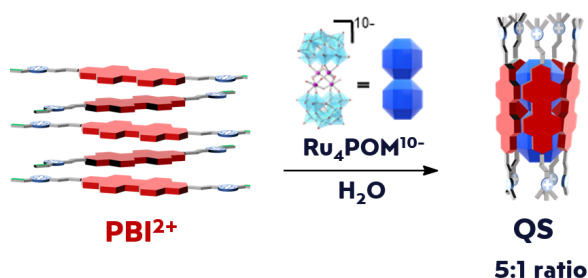

**Figure 1:** Self-assembly of Artificial Quantasome unit.

[1] Gobbo, P., Tian, L., Pavan Kumar, B.V.V.S. et al. *Nat. Commun.* 11 (2020) 41

[2] Bonchio, M., Syrgiannis, Z., Burian, M. et al. *Nature Chem.* 11 (2019) 146–153

[3] T. Gobbato, F. Rigodanza, E. Benazzi, P. Costa, M. Garrido, A. Sartorel, M. Prato\*, and M. Bonchio\**J. Am. Chem. Soc.* 144, 31 (2022) 14021–14025

## FL002

### Sulfated zirconias for the dehydration of d-sorbitol

Davide Baldassin,<sup>a</sup> Alessia Giordana,<sup>b</sup> Giuseppina Cerrato,<sup>b</sup> Federica Menegazzo,<sup>a</sup> and Michela Signoretto<sup>a</sup>

<sup>a</sup>Department of Molecular Sciences and Nanosystems, Ca' Foscari University of Venice, via Torino 155, 30170 Italy

<sup>b</sup> Department of Chemistry, University of Turin, Via Verdi 8, 10124 Torino, Italy  
E-mail: [davide.baldassin@unive.it](mailto:davide.baldassin@unive.it)

The utilization of renewable domestic resources and the establishment of a robust bio-based industry are imperative for achieving sustainability and fostering a circular economy. Sugars and their derivatives, sourced from diverse vegetal materials, serve as crucial renewable raw materials for such conversions. One reaction of interest is the double dehydration of d-sorbitol into isosorbide, a valuable building block for polymers, fragrances, and pharmaceuticals, ranked among the top 10 biobased platform chemicals by the US Department of Energy [1].

In this study, we investigate sulphated zirconias (SZ) as heterogeneous acidic catalysts with better stability and recyclability compared to the typically used homogeneous catalysts and acid resins. A significant challenge in this reaction is the formation of dark oligomeric species known as humins, which detrimentally affect catalyst activity over time [2]. Hence, a catalyst producing minimal heavy side-products and demonstrating stability at the temperatures of reaction is optimal. Sulphated zirconias were prepared via a precipitation method, sulphated with  $(\text{NH}_4)_2\text{SO}_4$  at varying weight percentages (7.5-12.5 wt%), and calcinated at different temperatures (550-600°C) before being tested in the dehydration of d-sorbitol into isosorbide. High selectivity to the desired product was achieved, which was found to be dependent on the synthesis parameters of the SZs, particularly sulfate content and calcination temperature. The acid site types were investigated through characterization of the material through FT-IR spectroscopy of suitable probe molecules to better understand the type of acid sites that lead to the desired product.

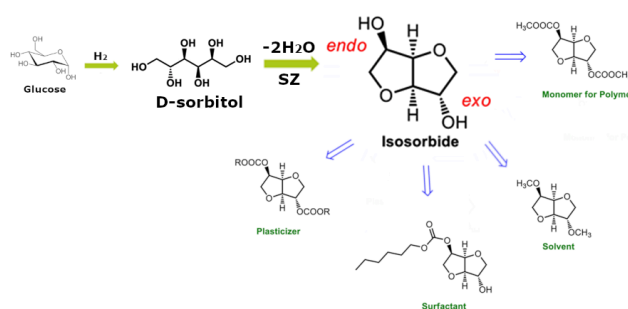

**Figure 1:** Scheme of reaction and main uses of product.

[1] J. J. Bozell, G. R. Petersen, *Green Chemistry* 12 (2010) 539-554

[2] C. Dusseigne, H. Wyart, V. Wiatz et al., *Molecular Catalysis* 463 (2019) 61-66

---

## FL003

### **Role of key intermediates of Oxygen Evolution on IrO<sub>2</sub>, RuO<sub>2</sub> and TiO<sub>2</sub> catalysts: a computational electrochemistry study**

Elisabetta Inico, Giovanni Di Liberto and Livia Giordano

*Dipartimento di Scienza dei Materiali, Università degli Studi di Milano-Bicocca, Via Roberto Cozzi 55, 20125 Milano, Italy*

*elisabetta.inico@unimib.it*

Water electrolysis is a key reaction for the transition to sustainable fuels and green energy production [1]. The Oxygen Evolution Reaction (OER) still needs to be improved in terms of efficiency and fundamental understanding of its chemistry. In terms of efficiency, RuO<sub>2</sub> is considered a promising candidate. OER is typically assumed to occur through the path OH\*, O\*, OOH\*.

Previous studies demonstrated that on RuO<sub>2</sub> unconventional intermediates can form. For instance, instead of forming OOH\*, the oxygen bond changes from hydroperoxide type (OOH) to superoxide (OO<sup>-</sup>H<sup>+</sup>) one [2].

In the presentation we systematically investigate the role of key reaction intermediates on three relevant metal oxides for electrocatalytic and photoelectrocatalytic OER, TiO<sub>2</sub>, RuO<sub>2</sub>, IrO<sub>2</sub> [3]. This study was conducted by first, investigating the stability by means of ab-initio thermodynamics, and then by looking at the critical role of solvation. Finally, static calculations were complemented by ab-initio molecular dynamic simulations.

Results allow to rationalize both the role of solvation in the stability and reactivity of OER intermediates, as well as the role of the electronic structure of the metal oxide, giving an interesting overview of the intermediates formation and stability.

[1] S. Divanis, A. M. Frandsen, T. Kutlusoy, J. Rossmeisl, Phys. Chem. Chem. Phys., 2021, 23, 19141

[2] G. Di Liberto, G. Pacchioni, Y. Shao-Horn, L. Giordano, J. Phys. Chem. C 2023, 127, 10127–10133

[3] Y. Lee, J. Suntivich, K. J. May, E. E. Perry, Y. Shao-Horn, J.Phys.Chem.Lett.2012, 3, 399–404

## Biogas upgrading: the role of Ni-based catalysts

Matteo Tommasi,<sup>a,b</sup> Alice Gramegna,<sup>b</sup> Simge Naz Degerli,<sup>b</sup> Ermelinda Falletta,<sup>a</sup> and Ilenia Rossetti<sup>a,b</sup>

<sup>a</sup> Department of Chemistry, Università degli Studi di Milano, Via C. Golgi 19, 20133 Milan, Italy

<sup>b</sup> INSTM Unit Milano-Università, Via C. Golgi 19, 20133 Milan, Italy

E-mail: [matteo.tommasi@unimi.it](mailto:matteo.tommasi@unimi.it)

Much has been said and written in recent times about possible solutions for CO<sub>2</sub> capture, conversion and storage. The role played by CCCS has become crucial and its importance is constantly growing together with the idea of storing surplus renewable energy under the form of green H<sub>2</sub>. At the same time, biogas upgrading relies on CO<sub>2</sub> removal to obtain biomethane with a suitable purity for NG-grid injection [1].

In this picture, biogas upgrading through thermo-catalytic CO<sub>2</sub> methanation is every day more appealing, since it avoids the costs associated with the CO<sub>2</sub> removal step [2].

This project focus on the use of Ni as active phase. Different metal oxides were used as support, such as Al<sub>2</sub>O<sub>3</sub>, SiO<sub>2</sub>, ZSM-5, TiO<sub>2</sub> and CeO<sub>2</sub>. Both in-house developed and commercial support have been used to synthesize the catalysts through wet-impregnation techniques. Tests have been conducted in two continuous tubular reactors, loaded with 200 mg of catalyst diluted in carborundum, at different GHSV. All the catalysts testes have been characterized through XRD, XPS, SEM, TEM, FT-IR, ICP and N<sub>2</sub> physisorption analysis.

Several catalysts, among which it is interesting to note 36% Ni/Al<sub>2</sub>O<sub>3</sub> and 36% Ni/CeO<sub>2</sub> showed high catalytic activities, approaching thermodynamic equilibrium at about 400°C and 350°C, respectively. Both catalysts, as reported in Figure 1, show near 100% selectivity to methane under the working conditions up to 400°C.

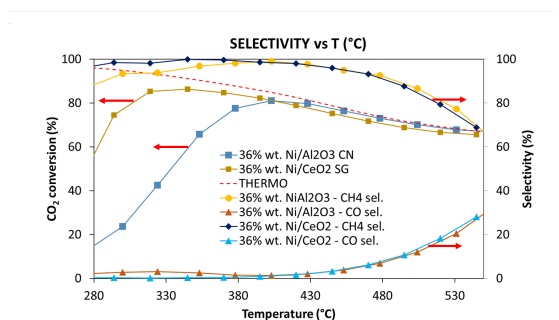

**Figure 1:** CO<sub>2</sub> conversion and selectivity as function of T

[1] I. Angelidaki, L. Treu, P. Tsapekos, G. Luo, S. Campanaro, H. Wenzel and P.G. Kougias, *Biotechnol. Adv.*, 36 (2018), 452–466

[2] M. Tommasi, S.N. Degerli, G. Ramis and I. Rossetti, *Chem Eng Res Des*, 201 (2023), 457–482

This study was carried out within the Agritech National Research Center, Next-GenerationEU (PIANO NAZIONALE DI RIPRESA E RESILIENZA (PNRR) – MISSIONE 4 COMPONENTE 2, INVESTIMENTO 1.4 – D.D. 1032 17/06/2022, CN00000022).

## Recovery of spent Lithium ion batteries and orange peel waste for the production of new heterogeneous photocatalyst

Giulia Maria Itri,<sup>a,b</sup> Francesco Mauriello,<sup>a</sup> Emilia Paone,<sup>a</sup> Giuseppe Marcì,<sup>c</sup> Elisa I. García-López<sup>c</sup>

<sup>a</sup>Dipartimento DICEAM, Università degli Studi Mediterranea di Reggio Calabria, IT89123 (RC)

<sup>b</sup> Università di Palermo, Viale delle Scienze, 90128 Palermo (PA)

<sup>c</sup> Università degli studi di Perugia, via Elce di sotto, 06123 (PG)

[giulia.itri@unirc.it](mailto:giulia.itri@unirc.it)

The generation of spent lithium-ion batteries (s-LIBs) worldwide amounts to millions of tons annually. While current recycling methods focus on extracting valuable metals like Ni, Co, and Li, they suffer from poor selectivity, high energy requirements, and expensive by-product management. Consequently, there's growing interest in exploring alternative methods for the direct reuse of s-LIBs [1]. At the same time, lignocellulosic and agro-industrial waste and residues represent a central feedstock for modern biorefineries aimed to the sustainable production of renewable energy and biobased materials and chemicals [2]. Technologies such as hydrothermal carbonization (HTC) have been proposed to upgrade orange peel waste (OPW), yielding hydrochar (OPW-HC) and liquid bio-oil (OPW-OIL), rich in furans derivatives like furfural and 5-HMF, pivotal in modern biorefineries [3]. OPW-OIL can be very rich in furans derivatives (furfural and 5-HMF) that represent one of the most important classes of intermediates in modern biorefineries

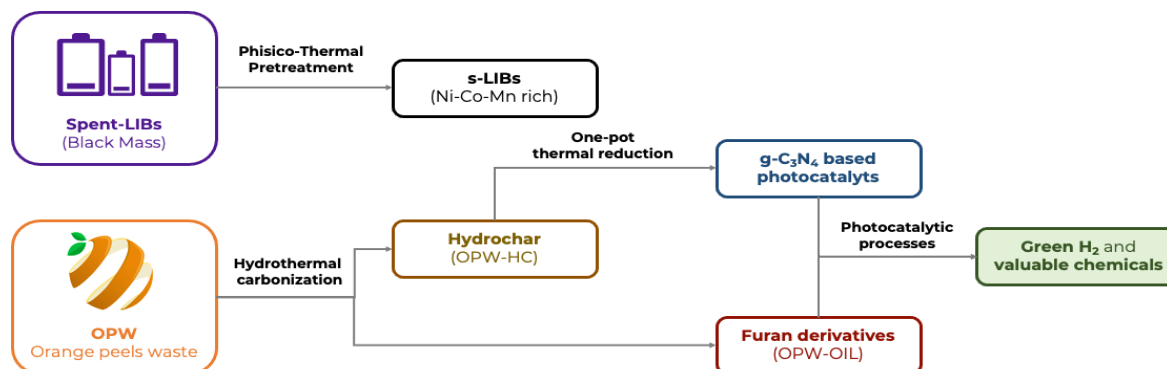

**Scheme 1.** Development of low-cost and robust heterogeneous photocatalysts starting from spent-Li ion batteries (s-LIBs) and orange peel waste (OPW) and in their application in the sustainable production of green H<sub>2</sub> and added value chemicals

**Figure 1:** Development of low-cost and robust heterogeneous photo-catalyst.

Starting from these two abundant wastes, we propose a simple direct approach to transform s-LIBs into a lithium (Li)-Co-Ni-Mn doped graphitic carbon nitride composites through one-pot in situ thermal process by using hydrochar as co-catalysts to improve the photocatalytic activity in H<sub>2</sub> production and value-added chemicals

#### References:

- [1] E. Paone, M. Miceli, et al., ACS Sustain. Chem. Eng. 2022, 10 (7), 2275-2281.
- [2] C. Xu, E. Paone, et al., Chem. Soc. Rev. 2020,49, 4273-4306.
- [3] A. Satira, E. Paone, et al., Applied Sciences 2021, 11 (22), 10983

## Hydroconversion of polyolefin plastic waste into fuels

Antonio Cosimo Pio Trimboli,<sup>a</sup> Elena Groppo,<sup>b</sup> Piero Torelli,<sup>c</sup> Francesco Mauriello,<sup>a</sup> Viviana Bressi,<sup>a</sup> and Emilia Paone<sup>a</sup>

<sup>a</sup> *Dipartimento DICEAM, Università degli Studi Mediterranea di Reggio Calabria, IT89123 Reggio Calabria, Italy*

<sup>b</sup> *Dipartimento di Chimica, NIS Interdepartmental Research Center and INSTM Reference Center, Università degli Studi di Torino, Via G. Quarello 15A, I-10135, Torino, Italy*

<sup>c</sup> *CNR-IOM, Area Science Park Basovizza, IT34149 Trieste, Italy*

*E-mail: [antoniocp.trimboli@unirc.it](mailto:antoniocp.trimboli@unirc.it)*

Millions of tons of poorly managed plastic waste accumulate in the environment annually, posing severe challenges to ecosystems. This issue is particularly acute with polyolefins (POs), where 95% of post-consumer POs become waste, accounting for over 60% of municipal solid waste plastic. The limited recycling of POs represents a significant gap in the plastic market loop, contradicting the objectives of the "European Strategy for Plastics in a Circular Economy." Although EU legislation suggests strategies for upcycling plastic waste, the upcycling of POs is still in its infancy. [1]

This project aims to increase awareness and advance the catalytic upcycling of PO waste into valuable liquid alkanes. The approach involves comprehensive characterization using multiple techniques to identify key catalyst properties and process variables that drive the selective cleavage of C-C bonds in POs.[2]

Two types of catalysts will be developed, featuring acid sites and ruthenium nanoparticles as active phases, with variations in acidity and support porosity. These catalysts will be compared to a commercial Ru/C catalyst. Various types of polyolefins, ranging from high purity to real waste, will undergo reductive conditions such as hydrocracking or hydrogenolysis, as well as transfer reductive conditions using aliphatic alcohols as green hydrogen donor molecules.

[1] European Commission, "A circular economy for plastics," can be found under <https://publications.europa.eu/en/publicationdetail/-/publication/33251cf9-3b0b-11e9-8d04-01aa75ed71a1/language-en>, 2019.

[2] C. Wang, Han H., Wu Y., Astruc D., *Coord. Chem. Rev.*, 458 (2022) 214422.

---

## FL007

### Rheology study of a heterogeneous catalyst

Giorgia Ferraro,<sup>a</sup> Nicola Ballarini,<sup>b</sup> and Michela Signoretto<sup>a</sup>

<sup>a</sup> Department of Molecular Sciences and Nanosystems, Ca' Foscari University of Venice and INSTM RU of Venice, via Torino 155, 30172 Venice, Italy

<sup>b</sup> Clariant, Via Fauser 36, 28100 Novara, Italy

E-mail: [giorgia.ferraro@unive.it](mailto:giorgia.ferraro@unive.it)

To decarbonize the chemical industry, a great number of applications, including sustainable chemical and fuel production, are being investigated [1]. Clariant, a Swiss multinational chemical company, is continuously investing in catalyst solutions within this field.

The aim of the research is to study and characterize a catalytic system used in a worldwide-scale process, in order to reintegrate it into the production cycle as part of a sustainable and circular perspective. Heterogeneous catalysts are particularly suitable for this purpose due to their ease of separation from products and consequent recyclability.

This study focuses on a paste-like heterogeneous catalyst. By examining the synthetic process steps, the project aims to assess the properties of the catalyst. To simulate process conditions and evaluate the potential regeneration of the catalyst, the material was stressed out and brought to the end of life through rheological studies.

Rheology, the study of the deformation and flow of matter, plays a crucial role in this research, as it assesses the catalyst's suitability for reuse or recycling in the same or different applications [2]. The catalyst was dispersed in water to form a homogeneous solution. In particular, rotational and oscillatory rheological tests were performed to investigate the viscosity, yield and flow points, and deformation behavior of the catalyst. The study considers different catalyst-to-water ratios (20:80, 30:70, 40:60) and temperatures (15°C, 25°C, 35°C).

The insights gained from this research will enable the optimization of catalytic process parameters, minimizing the energy, water, and time required, which is essential for the company's operational efficiency and sustainability goals.

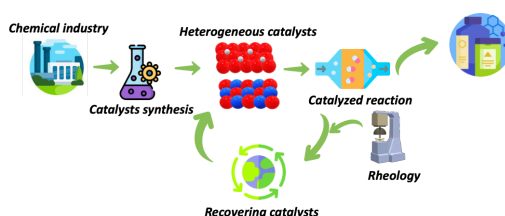

**Figure 1:** The idea of the catalyst's study.

[1] C.L. Basel, Clariant Ltd. <https://www.clariant.com/en/Business-Units/Catalysts/Decarbonization-and-Circular-Economy>.

[2] D. Yang, Y. Guo, H. Tang, D. Yang, P. Ming, C. Zhang, B. Li, and S. Zhu, *International Journal of Hydrogen Energy*, 47 (2022) 8956-8964

**NIR optical nanothermometer based on organic radicals:  
monitoring temperature in biological tissues**

Francesco Bertocchi,<sup>a</sup> Nerea González Pato,<sup>b</sup> Davide Blasi,<sup>b</sup> Domna N. Nikolaïdou,<sup>a</sup>  
Jesus Cerdá,<sup>c</sup> Andrea Lapini,<sup>a</sup> Francesca Terenziani,<sup>a</sup> Nora Ventosa,<sup>a</sup> Juan Aragón,<sup>c</sup>  
Jaume Veciana,<sup>a</sup> and Imma Ratera<sup>a</sup>

<sup>a</sup> *Dipartimento di Scienze Chimiche, della Vita e della Sostenibilità Ambientale, Università di Parma*  
*Institute of Materials Science of Barcelona (ICMAB)*

<sup>c</sup> *Instituto de Ciencia Molecular, Universitat de València, Catedrático José Beltrán 2, Paterna, 46980  
Spain*

*E-mail: francesco.bertocchi@unipr.it*

Accurate measurement of the local temperature of tissues and cell cultures is essential for understanding biological processes. NIR-to-NIR chromophores (i.e. chromophores which absorb and emit radiation in the NIR spectral range) have emerged as powerful spectroscopic probes for non-invasive temperature sensing due to the deep penetration of NIR radiation into biological tissues. Two-Photon Absorption (TPA) microscopy guarantees reduced photobleaching and intrinsic three-dimensional resolution.

We report the preparation and spectroscopic characterization of photostable organic nanoparticles (ONPs) of TTM- $\alpha$ H doped with a polychlorinated trityl radical, TTM [1]. TTM radicals exist either as isolated radicals or form excimers within the ONPs. The excimers can be two-photon excited, potentially working as promising NIR-to-NIR optical probes. The ratio between the intensities of monomer and excimer emissions significantly increases with increasing temperature [2]. This allows to reliably monitor temperature changes of a sample in a range between 278 and 328 K. The ratio of excimer to monomer emission is monitored both in an ONP water suspension (upon linear and two-photon excitation) and in an enucleated pig eye sclera (via two-photon microscopy), showing an excellent linear correlation with temperature and thus demonstrating the potential of TTM ONPs as nanothermometers for biological applications [3].

[1] D. Blasi, D. M. Nikolaidou, F. Terenziani, I. Ratera, J. Veciana, *Phys. Chem. Chem. Phys.* 19 (2017) 9313–9319

[2] D. Blasi, N. Gonzalez-Pato, X. Rodriguez-Rodriguez, I. Diez-Zabala, S. Sumithra, N. Camarero, O. Esquivias, M. Roldán, J. Guasch, A. Laromaine, P. Gorostiza, J. Veciana, I. Ratera, *Small* 19 (2023) 2207806

[3] N. Gonzalez-Pato, D. Blasi, D. M. Nikolaidou, F. Bertocchi, J. Cerdá, F. Terenziani, N. Ventosa, J. Aragón, A. Lapini, J. Veciana, I. Ratera, *Small Methods* 8 (2024) 2301060



## FL010

# Innovative on-resin and in solution peptidomimetics synthesis via metal-free photocatalytic approach

Zoe Laface, Tommaso Gandini, Maria Luisa Gelmi, and Raffaella Bucci

*DISFARM, Sezione di Chimica Generale e Organica "A. Marchesini" Università degli Studi di Milano, 20133 Milano, via Venezian 21, Italy.*

*E-mail: [zoe.laface@unimi.it](mailto:zoe.laface@unimi.it)*

The project here presented will regard the study of innovative strategies to prepare peptidomimetics, molecules able to mimic the properties of natural peptides but with a non-natural backbone, that enhance the affinity and metabolic stability, with the possibility to employ them in nanomaterials [1]. Differently from the classical methods, where the amino acid must be first synthesized and then inserted into the peptide sequence, our photocatalytic approach allows the generation of the non-coded amino acid directly in the peptide sequence, through the formation of the C $\alpha$ -CO bond.

In this work, we have investigated a metal-free photoredox-catalyzed approach, by using 4CzIPN as the organic photocatalyst (PC) to access the  $\alpha$ -amino amide scaffold. As starting materials, aldimines and 4-amido Hantzsch ester (HE) derivatives, as radical precursors were used, forming the new C-C bond and pyridine (HP) as by-product (Figure 1) [2]. 4CzIPN is a donor-acceptor cyanoarene, vastly used in photoredox catalysis [3], as it can be easily prepared on a large scale from inexpensive compounds. Moreover, it is bench-stable and less toxic compared to Ru- and Ir-based PCs.

We have also successfully applied this approach to solid-phase peptide synthesis, producing peptides of different lengths and secondary structures, demonstrating the success of this protocol even in a sterically hindered environment.

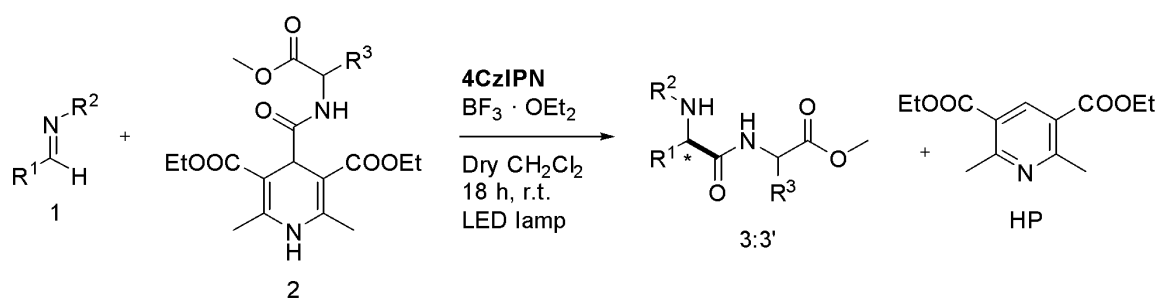

**Figure 1:** In situ synthesis of ultrashort peptidomimetics.

[1] E. Lenci, A. Trabocchi, *Chem. Soc. Rev.* 49 (2020) 3262-3277; R. Bucci, F. Foschi, C. Loro, E. Erba, M. L. Gelmi, S. Pellegrino, *Eur. J. Org. Chem.* 2021 (2021) 2887-2900.

[2] P.-Z. Wang, J.-R. Chen, W.-J. Xiao, *Org. Biodioli. Chem.* 17 (2019) 6936-6951; J. K. Matsui, S. B. Lang, D. R. Heitz, G. A. Molander, *ACS Catal.* 7 (2017) 2563-2575.

[3]. M. A. Bryden, E. Zysman-Colman, *Chem. Soc. Rev.* 50 (2021) 7587-7680.

## FL011

### Metal and (photo)catalyst-free difunctionalization reactions via arylazo sulfone as visible-photoactive reagent

Luca Nicchio,<sup>a,b,c</sup> Lorenzo Di Terlizzi,<sup>a</sup> Camilla Callegari,<sup>a</sup> Simone Scaringi,<sup>a</sup> Maurizio Fagnoni,<sup>a,c</sup> G. Masson,<sup>b</sup> Luc Neuville,<sup>b</sup> and Stefano Protti<sup>a,c</sup>

<sup>a</sup> Department of Chemistry, University of Pavia, Viale Taramelli 12, 27100-Pavia, Italy

<sup>b</sup> Institut de Chimie des Substances Naturelles, CNRS UPR 2301, Université Paris-Saclay, 1 Avenue de la Terrasse, 91198-Gif sur Yvette, Cedex, France

<sup>c</sup> UdR INSTM of Pavia

E-mail: luca.nicchio01@universitadipavia.it

Photochemical approaches for vicinal difunctionalizations mainly relied on the use of a photocatalyst to generate the reactive intermediates [1]. Besides, an alternative route employs molecules bearing a dyedauxiliary group, allows the generation of high reactive intermediate without a (photo)catalyst. In this context, arylazo sulfones are well applied under visible irradiation as precursor of three possible species: sulfonyl, aryldiazenyl and aryl radicals, becoming a suitable photoactive reagents for 1,2-difunctionalization reactions [2].

Indeed, under blue light irradiation, arylazo sulfones can be used as aryl radical source in presence of an  $\alpha$ -substituted styrene and an alcohol in Meerwein carboetherifications (pathway **a**) while in the presence of normal styrenes they act as bifunctional photoactive reagents retaining both sulfonyl and aryldiazenyl moiety in the final product (pathway **b**) [3]. The bifunctional approach can be also extended to the preparation of more complex substrates such as 1,2,4-triazoles (pathway **c**) by difunctionalization of *N*-alkenyl amides **2** under irradiation of the arylazo sulfone **1**.

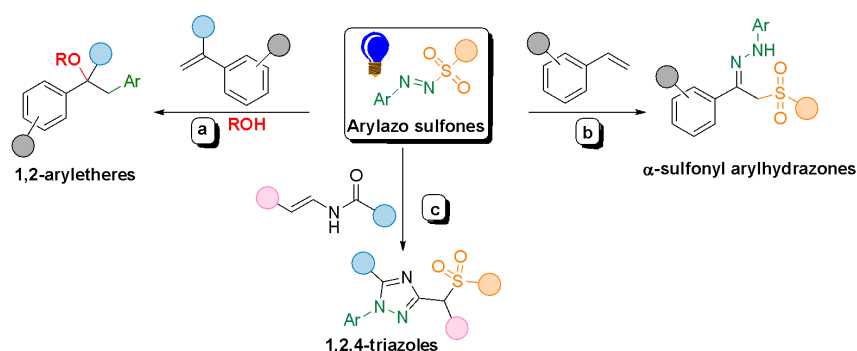

**Figure 1:** Summary of 1,2-difunctionalizations via arylazo sulfones.

These approaches prove to be a valid metal and (photo)catalyst-free way for visible-light-mediated vicinal difunctionalization of olefins, obtaining targeting products in high atom economy and broad range of substitution.

[1] B. Dong, J. Shen and L.G. Xie, *Org. Chem. Front.* 10 (2023) 1322-1345

[2] L. Di Terlizzi, L. Nicchio, S. Protti and M. Fagnoni, *Chem. Soc. Rev.* 53 (2024) 4926-4975

[3] L. Di Terlizzi, L. Nicchio, C. Callegari, S. Scaringi, L. Neuville, M. Fagnoni, S. Protti and G. Masson, *Org. Lett.* 25 (2023) 9047-9052

---

## FL012

### Fluorescent labelling of Human Serum Albumin

Jacopo Venditti,<sup>a</sup> Mario Saletti,<sup>a</sup> Marco Paolino,<sup>a</sup> Germano Giuliani,<sup>a</sup> Claudia Bonechi,<sup>a</sup>  
Giusy Tassone,<sup>a</sup> Antonella Boccia,<sup>b</sup> Chiara Botta,<sup>b</sup> and Andrea Cappelli<sup>a</sup>

<sup>a</sup> *Dipartimento di Biotecnologie, Chimica e Farmacia, Università degli Studi di  
Siena, Via A. Moro 2, 53100, Siena.*

<sup>b</sup> *Istituto di Scienze e Tecnologie Chimiche “G. Natta” – SCITEC (CNR), Via A. Corti 12, 20133, Milano*

*E-mail: jacopo.venditti@student.unisi.it*

Human Serum Albumin (**HSA**) is the most abundant protein in human plasma where performs multiple functions like the regulation of oncotic pressure and the transport of endogenous and exogenous substances. **HSA** represents an appealing drug delivery system (DDS) due to its high biocompatibility, biodegradability and nonimmunogenicity. Interesting examples are Abraxane, a nanoparticle formulation of paclitaxel-loaded **HSA**, Jevtana, a cabazitaxel-loaded **HSA**-based nanoparticles, and methotrexate-**HSA** conjugate used as an anticancer platform and for the treatment of rheumatoid arthritis [1]. In this contest, a fluorescent Morita-Baylis-Hillman-Adduct (MBHA) derivative was designed, synthesized [2], and allowed to react with **HSA** shifting its emission from the blue to the green-yellow and allowing the formation of Green Fluorescent Albumin (**GFA**) derivatives [3]. Biological studies suggested that **GFA** retained the same properties of native **HSA** as drug carrier and potential drug delivery system.

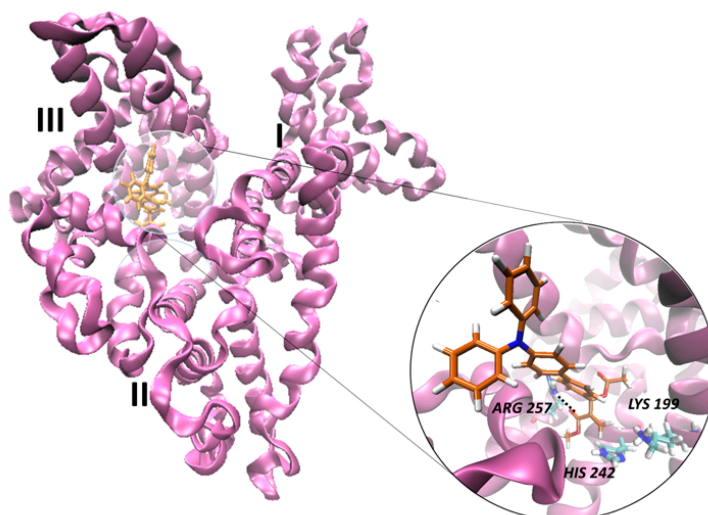

**Figure 1:** Interaction of MBHA derivative with Human Serum Albumin.

[1] A. Spada, J. Emami, J.A. Tuszynski, and A. Lavasanifar, *Mol. Pharm.* 18 (2021) 1862-1894

[2] M. Saletti, M. Paolino, J. Venditti, C. Bonechi, G. Giuliani, A. Boccia, C. Botta, and A. Cappelli, *Dyes Pigm.* 219 (2023) 111571

[3] M. Saletti, M. Paolino, J. Venditti, C. Bonechi, G. Giuliani, S. Lamponi, G. Tassone, A. Boccia, C. Botta, L. Blancafort, F. Poggialini, C. Vagaggini, and A. Cappelli, *ChemBioChem* 25 (2024) e202300862

## Biomanufacturing of commodity chemicals from cheese whey permeate

Lorenza Cassano,<sup>1</sup> Debora Dallera,<sup>2</sup> Michela Casanova,<sup>2</sup> Lorenzo Pasotti,<sup>2</sup> Paolo Magni,<sup>2</sup> Daniela Ubiali,<sup>1</sup> and Marina S. Robescu<sup>1</sup>

<sup>1</sup> Department of Drug Sciences, University of Pavia, viale Taramelli 12, 27100-Pavia, Italy

<sup>2</sup> Department of Electrical, Computer and Biomedical Engineering, University of Pavia, via Ferrata 5, 27100-Pavia, Italy

E-mail: [lorenza.cassano01@universitadipavia.it](mailto:lorenza.cassano01@universitadipavia.it)

The global concerns about climate change, environmental pollution, and the loss of biodiversity have raised the awareness for the urgent need of a shift from a fossil resource-based economy to a sustainable circular economy based on carbon-neutral chemicals manufactured from renewable biomass [1].

Whey permeate (WP), the main byproduct of the cheese-making industry, was used both as fermentation medium for engineered bacteria to produce bioethanol [2], and as feedstock for the enzymatic synthesis of Sugar Fatty Acid Esters (SFAE), that are nonionic surfactants. Both these processes, however, generate effluents that are unused. These effluents were, indeed, recovered and integrated in a unique “zero-waste” biorefinery: residual lactose from fermentation was used as the substrate for SFAE production, while residual glucose from biocatalysis was used as growth medium for bacterial inoculum preparation. Transesterification of used cooking oil with bioethanol to produce biodiesel and anaerobic digestion of the generated wastewaters for biogas production will close the loop (**Figure 1**).

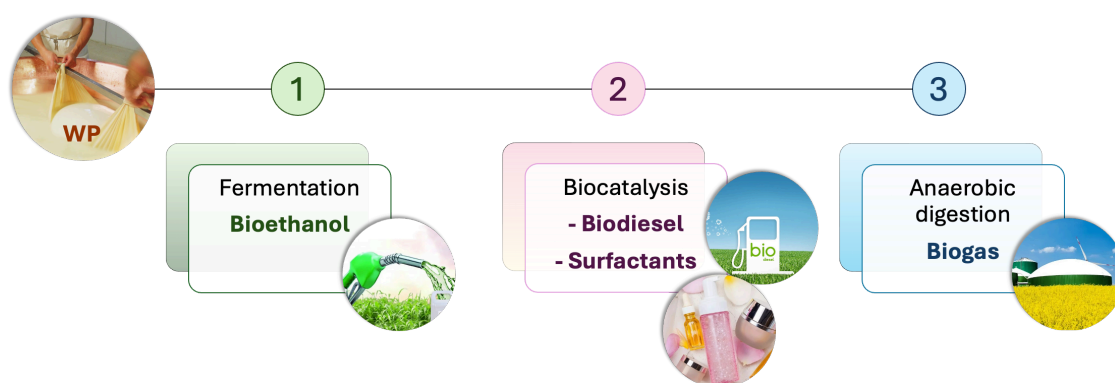

**Figure 1:** Integrated biorefinery for biomanufacturing commodity chemicals (surfactants and biofuels).

### Acknowledgements

This abstract is part of the project NODES which has received funding from the MUR – M4C2 1.5 of PNRR funded by the European Union - NextGenerationEU (Grant agreement no. ECS00000036).

[1] R.A. Sheldon, D. Brady, *ChemSusChem* 15 (2022) e202102628

[2] L. Pasotti, D. De Marchi, M. Casanova, A.F. Frusteri Chiacchiera, M.G. Cusella De Angelis, C. Calvio, P. Magni, *Biotechnol. biofuels bioprod* 16 (2023) 57

## Boronic acids: a new strategy to boost beta-lactam antibiotics as anti-tuberculosis agents

Valentina Villamil,<sup>a</sup> Cristina López,<sup>b</sup> Rita Sorrentino,<sup>c</sup> Marcellus Ubbink,<sup>b</sup> Daniela Cirillo,<sup>c</sup> Fabio Prati,<sup>a</sup> and Emilia Caselli<sup>a</sup>

<sup>a</sup> *Dipartimento di Scienze della Vita, Università di Modena & Reggio Emilia, Via Giuseppe Campi 103, 41124-Modena, Italy*

<sup>b</sup> *Leiden Institute of Chemistry, University of Leiden, Rapenburg 70, 2311-Leiden, Netherlands*

<sup>c</sup> *Division of Immunology, Transplantation and Infectious Diseases, IRCCS San Raffaele Scientific Institute, Via Olgettina, 60, 20132-Milan, Italy*

E-mail: [vivalent@unimore.it](mailto:vivalent@unimore.it)

Tuberculosis (TB) is a highly infectious disease caused by *Mycobacterium tuberculosis* (*Mtb*), one of the most dangerous aerobic bacteria. In 2020 alone, TB was responsible for 1.5 million deaths worldwide, comparable to the 1.8 million deaths caused by COVID-19. The need for long-term treatments and the increase in drug resistance mechanisms make it necessary to urgently develop new strategies to combat this potentially lethal pathogen.  $\beta$ -Lactam Antibiotics (BLA) are the most widely used and safest antibiotics in the clinic and include several classes such as penicillins, cephalosporins and carbapenems. However, historically these agents have not been used to treat TB. The main resistance mechanisms to BLA in *Mtb* relies on the expression of BlaC, a specific  $\beta$ -lactamase enzyme capable of hydrolyzing and inactivating the BLA. Recent studies have shown that the combination of meropenem (a  $\beta$ -lactam carbapenem), amoxicillin (a  $\beta$ -lactam penicillin) and clavulanate (a  $\beta$ -lactamase inhibitor) markedly reduced the *Mtb* load in the patient's sputum after two weeks, therefore giving new hope to the use of BLA to tackle the tuberculosis epidemic. In the past twenty years, several Boronic acid transition state inhibitors BATSIs were synthesized by Prof. Prati's group as inhibitors of Serine BL enzymes to combat BLA resistance expressed in highly resistant Gram-negative bacteria (*Klebsiella*, *Acinetobacter*, *Pseudomonas*). Some of them proved to inhibit these enzymes in the nanomolar range. These compounds form a reversible covalent bond between the boron atom and the catalytic serine residue forming a complex with the enzyme which mimic the transition state of the hydrolysis reaction of the BLA, leading to enzyme inactivation and allowing BLA activity restoration. The rise of interest on a possible use of BLA against *Mtb* has encouraged our group to investigate whether the BATSIs, could synergize the activity of a BLA in *Mtb*. Thus, several BATSIs were chosen and evaluated against BlaC-producing *E. coli* strains in combination with ampicillin and cefuroxime in a first screening. Those compounds able to increase BLA susceptibility against BlaC-producing *E. coli* were chosen for further studies, and then the kinetic parameters  $K_i$  and  $IC_{50}$  were determined. In future works, we aim to assay the best compounds against BlaC-producing *Mtb* reference strains for an anti-tubercular treatment.

## Novel Agents Against Biofilm Formation: Design, Synthesis and Biological Evaluation of LsrK Ligands as AI-2 Quorum Sensing Inhibitors

Giorgio Milli,<sup>a</sup> Angelica Pellegrini,<sup>b</sup> Roberta Listro,<sup>a</sup> Giampiero Pietrocola,<sup>b</sup> Pasquale Linciano,<sup>a</sup> and Simona Collina.<sup>a</sup>

<sup>a</sup>Department of Drug Science, University of Pavia, Viale Taramelli 12, 27100 Pavia, Italy

<sup>b</sup>Department of Molecular Medicine, Biochemistry unit, University of Pavia, Viale Taramelli 3/b, 27100 Pavia, Italy

Email: giorgio.milli01@universitadipavia.it

The rise of bacterial strains resistant to conventional antimicrobial drugs underscores the urgent need to identify new targets for developing novel antibacterial treatments. A promising strategy to address antibiotic resistance is to interfere with biofilm formation and bacterial Quorum Sensing (QS), a key communication mechanism adopted by bacteria to coordinate collective behaviours. QS is regulated and triggered by small molecules called autoinducers. The autoinducer-2 (AI-2, known as 4,5-dihydroxy-2,3-pentandione or DPD) is of relevance since it is a universal signalling molecule exploited by both Gram-positive and Gram-negative bacteria. AI-2-mediated QS is triggered through the phosphorylation of DPD by the LsrK kinase, making LsrK a critical enzyme in this signalling pathway [1]. Thus, targeting LsrK may be an effective approach to combat biofilm-associated infections. Despite its significance, LsrK is still underexplored from a medicinal chemistry standpoint. In our study, we prepared a small library of twenty-one AI-2 related compounds. All the compounds were assessed for their ability to inhibit biofilm formation in two relevant pathogenic bacterial strains of *S. aureus* and *P. aeruginosa*, as model of Gram-positive and -negative bacteria. The most performing compounds showed inhibition in biofilm formation against both strains, with MBIC<sub>50</sub> in the low micromolar range. Further assessments confirmed that these inhibitors did not exhibit bactericidal or bacteriostatic activity, and that their antibiofilm activity was mediated by selective quenching of AI-2 mediated QS in *V. harveyi* strains. Lastly, the successful binding to LsrK, confirmed by various spectroscopic methods, provided insight into the mechanistic aspects of QS inhibition. In conclusion, our research marks a critical advance in identifying compounds that could contribute to the fight against antibiotic resistance.

[1] Pasquale Linciano, Valeria Cavalloro, Emanuela Martino, Johannes Kirchmair, Roberta Listro, Daniela Rossi, and Simona Collina. *J. Med. Chem.* (2020), 63 (24), 15243–15257.

**Cancer cells multidrug resistance? NO thank you.**

Federica Sodano,<sup>a</sup> Maria Cristina Molaro,<sup>a</sup> Benedetta Romano,<sup>a</sup> Marica Erminia Schiano,<sup>a</sup> Chiara Battisegola,<sup>a</sup> Fabio Somma,<sup>a</sup> Konstantin Chegaev,<sup>b</sup> Loretta Lazzarato,<sup>b</sup> Barbara Rolando,<sup>b</sup> Chiara Riganti,<sup>c</sup> and Giuseppe Ercolano<sup>a</sup>

<sup>a</sup> *Dipartimento di Farmacia, Università degli Studi di Napoli Federico II, Via Domenico Montesano 49, 80131-Napoli, Italia*

<sup>b</sup> *Dipartimento di Scienza e Tecnologia del Farmaco, Università degli Studi di Torino, Via Pietro Giuria 9, 10125- Torino, Italia*

<sup>c</sup> *Dipartimento di Oncologia, Università di Torino, 10126- Torino, Italia*

E-mail: [federica.sodano@unina.it](mailto:federica.sodano@unina.it)

Cancer remains one of the leading causes of death in developed countries, despite significant advances in understanding its mechanisms. Chemotherapy continues to be the preferred treatment method, but its efficacy is often hindered by multidrug resistance (MDR). This resistance is frequently mediated by transporters such as P-glycoprotein, which expel anticancer drugs from tumour cells. Efforts to inhibit these transporters with small molecules have proven challenging, prompting the exploration of alternative strategies. Among various efflux pump inhibitors, nitric oxide (NO), a small gaseous molecule, has shown promise. However, NO cannot be administered directly; it must be generated by stable chemical entities known as NO donors (NODs) under specific conditions such as enzyme activity, subcellular localization, cellular factors, or light irradiation. Once produced in tumour cells, NO can initiate protein modifications (oxidation, nitrosation, nitration) that inactivate some of the transporters responsible for MDR, thereby increasing the intracellular accumulation of antineoplastic agents [1-2]. The flexibility of this approach lies in the possibility of chemically binding an anti-cancer drug with a NOD substructure. Furthermore, among the various known NO donors, it is possible to select those preferentially activated by enzymes or factors overexpressed in tumour cells to increase selectivity.

Following this line of research, we explored the possibility of conjugating doxorubicin (DOXO), an anticancer drug with a broad spectrum of action, with FS506, a diazene diolate prodrug (also called NONO-ate) - into a single molecular hybrid known as FS536. The chemical and enzymatic stability of FS536 were evaluated, and the cytotoxicity and mechanism of action of FS536 in human cancer cell lines and their drug-resistant counterparts were investigated.

[1] K. Chegaev, C. Riganti, L. Lazzarato, B. Rolando, S. Guglielmo, R. Fruttero, A. Bosia, A. Gasco, *ACS Med Chem Lett* 2 (2011) 494-497.

[2] C Riganti, B. Rolando, J. Kopecka, I. Campia, K. Chegaev, L. Lazzarato, A. Federico, R. Fruttero, D. Ghigo, *Mol Pharm* 10 (2013) 161-174.

## Targeted degraders of eIF6: a novel strategy to remodulate liver pathological lipidic metabolism

Alessio Colleoni,<sup>ab</sup> Enrico Mario Alessandro Fassi,<sup>a</sup> Annarita Miluzio,<sup>c</sup> Marco Albani,<sup>a</sup> Davide Lecchi,<sup>a</sup> Giorgia Tempa,<sup>a</sup> Marco De Amici,<sup>a</sup> Giovanni Grazioso,<sup>a</sup> Stefano Biffo,<sup>b,c</sup> and Carlo Matera<sup>a</sup>

<sup>a</sup> Department of Pharmaceutical Sciences, University of Milan, Via Mangiagalli 25, 20133, Milan, Italy

<sup>b</sup> Department of Biosciences, University of Milan, Via Celoria 26, 20133 Milan, Italy

<sup>c</sup> National Institute of Molecular Genetics, Fondazione “Romeo ed Enrica Invernizzi”, 20122, Milan, Italy

E-mail: [alessio.colleoni@unimi.it](mailto:alessio.colleoni@unimi.it)

Among the crucial mechanisms involved in gene expression, translational control has proved to play a pivotal role. eIF6, a translation initiation factor that operates downstream of the insulin pathway, has recently emerged as a potential drug target: mice heterozygous for this factor reduce the upregulation of protein synthesis under postprandial conditions and exhibit reduced white fat accumulation [1]. It is well-known that increased lipid accumulation in the liver leads to non-alcoholic fatty liver disease (NAFLD), which can progress to non-alcoholic steatohepatitis (NASH) and eventually to hepatocellular carcinoma (HCC), a leading cause of cancer-related death worldwide. Notably, fatty liver is the fastest-growing cause of liver failure and HCC. Recent studies have shown that genetic inhibition of eIF6 reduces lipid metabolism and impedes NAFLD to HCC progression [2].

Based on these studies, inhibiting eIF6 could represent an effective strategy to prevent the pathological development of NAFLD, its progression to NASH, and subsequently to HCC, as well as the progression of existing HCC. To test this hypothesis, we designed selective degraders of eIF6 based on the molecular skeleton of known eIF6 binders previously identified and applied the emerging “proteolysis targeting chimera” (PROTAC) strategy.

Thus, an *in silico* study of a set of degraders of eIF6 was performed, combining docking, molecular dynamics simulations and ligand binding free energy (MM-GBSA) approaches. The top scoring candidates are currently under development: the design, synthesis and characterization of these novel, putative PROTACs will be presented and discussed.

### References:

[1] A. Scagliola, A. Miluzio, G. Ventura, S. Oliveto, A. Bresciani, S. Biffo. *Nat. Commun.* (2021), 12(1), 4878.

[2] A. Scagliola, A. Miluzio, G. Mori, S. Ricciardi, S. Oliveto, N. Manfrini, S. Biffo S. *Int. J. Mol. Sci.* (2022), 23(14), 7720

## A new biocompatible butyric acid-releasing glucosamine derivative for transdermal delivery

Chiara Billi,<sup>a</sup> Marica Erminia Schiano,<sup>a</sup> Ritamaria Di Lorenzo,<sup>a</sup> Loretta Lazzarato,<sup>b</sup> Barbara Rolando,<sup>b</sup> Mariarosaria Cuozzo,<sup>a</sup> Fabiana Filogamo,<sup>a</sup> Carlo Irace,<sup>a</sup> Maria Grazia Ferraro,<sup>a</sup> Sonia Laneri,<sup>a</sup> Federica Sodano,<sup>a</sup> and Maria Grazia Rimoli<sup>a</sup>

<sup>a</sup> Dipartimento di Farmacia, Università degli studi di Napoli "Federico II" via Domenico Montesano 49, 80131-Napoli, Italia

<sup>b</sup> Dipartimento di Scienza e Tecnologia del Farmaco, Università degli Studi di Torino, Via Giuseppe Verdi 8, 10125-Torino, Italia

E-mail: [chiara.billi@unina.it](mailto:chiara.billi@unina.it)

The carrier prodrug approach is a medicinal chemistry strategy adopted to refine the physicochemical and biopharmaceutical properties of parent drugs [1-2].

In the present work, sketched in Figure 1, this strategy was applied to improve the transdermal absorption of butyric acid (BA) by using a natural and nontoxic molecule, D-glucosamine (*N*-Glc), as a carrier. Accordingly, the design and synthesis of a new carrier prodrug, *N*-glucosamine tetrabutyrate (3-amino-6-((butyryloxy)methyl)tetrahydro-2H-pyran-2,4,5-triyl tributyrate, *N*-Glc-BE) is reported. The chemical and enzymatic stability of *N*-Glc-BE under different pH conditions and in human serum, along with lipophilicity and solubility, were evaluated. *N*-Glc-BE demonstrated chemical stability across various pH conditions but was hydrolyzed in the presence of esterase with a *half-life* of 8 minutes in human serum. The prodrug exhibited optimal solubility and a favourable hydrophilic-lipophilic balance. Its ability to permeate through skin layers was assessed using the Franz diffusion cell methodology. *N*-Glc-BE predominantly accumulated in the epidermis and dermis, and it reached the receptor compartment slowly and sustained over time while releasing its parent drug, BA. Finally, its biocompatibility was demonstrated in preclinical human skin models, including primary cultures.

In light of the results obtained, the new odourless prodrug *N*-Glc-BE proves to be a promising candidate for the transdermal delivery of BA, a molecule with multiple biological properties but a disadvantageous physicochemical profile. Using *N*-Glc as a carrier not only ensures non-toxicity but also leverages its important role in skin health and beyond.

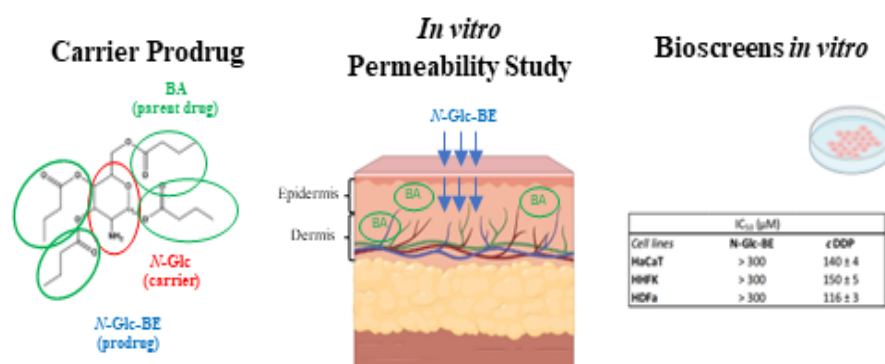

**Figure 1:** Graphical illustration of the present study.

[1] F. Sodano, C. Cristiano, B. Rolando, et al, *Pharmaceuticals* 15 (2022) 552

[2] C. Battisegola, C. Billi, M.C. Molaro, et al, *Pharmaceuticals* 17 (2024) 308.

## Novel macrocyclic derivatives as MerTK selective inhibitors for targeted cancer therapy

Andrea Baldi,<sup>a</sup> Andrea Sodini,<sup>a</sup> Paola Chiarugi,<sup>b</sup> Mattia Mori,<sup>c</sup> Fabio Marra,<sup>d</sup> and Cristina Nativi<sup>a</sup>

<sup>a</sup> Department of Chemistry, University of Florence, Via della Lastruccia 3-13, 50019-Sesto Fiorentino, Italy

<sup>b</sup> Department of Biomedical, Experimental, and Clinical Sciences 'Mario Serio', University of Florence, Viale Morgagni Giovan Battista 59, 50134-Firenze, Italy

<sup>c</sup> Department of Biotechnology, Chemistry, and Pharmacy, University of Siena, via Aldo Moro 2, 53100-Siena, Italy

<sup>d</sup> Department of Experimental and Clinical Medicine, University of Florence, Largo Brambilla 3, 50134-Firenze, Italy

E-mail: [andrea.baldi@unifi.it](mailto:andrea.baldi@unifi.it)

MerTK, a receptor tyrosine kinase belonging to the TAM family, plays crucial roles in both normal cells and cancer events. Specifically, it is overexpressed in several cancers and the activation by its ligands, Gas6 and Protein S, enhances cancer cell invasion, migration, chemoresistance, and metastasis, making this enzyme an encouraging target for anticancer therapies. In this context, due to the conserved kinase domain in tyrosine kinase receptors, the challenge is developing highly selective MerTK inhibitors to prevent off-target effects [1]. Recently, macrocyclic pyrimidines have emerged as promising selective MerTK inhibitors [2]. This study focuses on the design, synthesis, and biological evaluation of new inhibitors analogues of compound **1** (UNC2541).

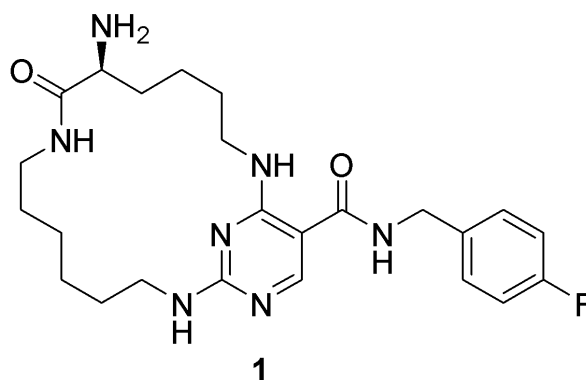

[1]. Lahey, K. C., Gadiyar, V., Hill, A., Desind, S., Wang, Z., Davra, V., Patel, R., Zaman, A., Calianese, D., & Birge, R. B., *Int Rev Cell Mol Biol.* (2022), 368, 35.

[2]. McIver, A. L., Zhang, W., Liu, Q., Jiang, X., Stashko, M. A., Nichols, J., Miley, M. J., Norris-Drouin, J., Machius, M., DeRyckere, D., Wood, E., Graham, D. K., Earp, H. S., Kireev, D., Frye, S. V., & Wang, X., *ChemMedChem* (2017), 12(3), 207.

## Exploring the synthesis and cytotoxicity of Pd(I) dimers bearing phosphine and isocyanide ligands

Eleonora Botter,<sup>a</sup> Jacopo Viviani,<sup>a</sup> Nicola Demitri,<sup>b</sup> Flavio Rizzolio,<sup>a,c</sup> Thomas Scattolin,<sup>d</sup> and Fabiano Visentin<sup>a</sup>

<sup>a</sup> Department of Molecular Sciences and Nanosystems, Università Ca' Foscari Venezia, Campus Scientifico Via Torino 155, 30174-Mestre (VE), Italy

<sup>b</sup> Elettra-Sincrotrone Trieste, S.S. 14 Km 163.5 in Area Science Park, 34149-Basovizza (TS), Italy

<sup>c</sup> Pathology Unit, Department of Molecular Biology and Translational Research, Centro di Riferimento Oncologico di Aviano (CRO) IRCCS via Franco Gallini 2, 33081-Aviano (PN), Italy

<sup>d</sup> Department of Chemical Science, Università degli Studi di Padova, Via Marzolo 1, 35131-Padova (PD), Italy

E-mail: [eleonora.botter@unive.it](mailto:eleonora.botter@unive.it)

Cancer is currently a very widespread malignancy, and its treatment is still one of the major challenges of our days. Among others, ovarian cancer has one of the higher percentages of death because of a combination of late diagnosis and low treatment options. In fact, first line therapy is still represented by surgery and cisplatin chemotherapy. The latter has issues related to general toxicity and development of resistance [1]. Thus, the development of new anticancer drug is of primary relevance.

In the landscape of metallodrugs for cancer therapy, organopalladium complexes have emerged as promising candidates. Interestingly, the presence of an organic ligand that allows the formation of a strong Pd-C bond can both stabilize the metal center and work as new active site, possibly leading to a multitarget approach. Different Pd(II) and Pd(0) compounds were synthesized and tested in the last years, leading to interesting results in terms of activity and sometimes selectivity towards cancer cells. Instead, Pd(I) complexes were further less explored, especially from a biological point of view [2].

In this presentation, we describe the synthesis and characterization of new Pd(I) dimers bearing phosphine and isocyanide ligands. The compounds were obtained by simply adding an excess of the isocyanide ligand to [Pd(Ind)(P(Ar)<sub>3</sub>)(CNR)] precursors (Ar = C<sub>6</sub>H<sub>6</sub>, *p*-F-C<sub>6</sub>H<sub>5</sub>, *p*-Cl-C<sub>6</sub>H<sub>5</sub>, *p*-OMe-C<sub>6</sub>H<sub>5</sub>, Py; R = *t*-Bu, Cy, adamantyl) [3], leading to the selective formation of only one among the possible isomers. All complexes were fully characterized via NMR and IR techniques and, when possible, the X-ray diffraction structure was also obtained, thus confirming the corner-sharing geometry of these compounds, which contains a Pd-Pd bond and no bridging ligands. Moreover, the obtained complexes were tested against 4 ovarian cancer cell lines (A2780, A2780*cis*, KURAMOCHI, OVCAR-5) and a normal one (MRC-5), pointing out an interesting cytotoxicity, that most of the times is higher than cisplatin, with a certain selectivity toward cancer cells.

[1] M. Song, M. Cui, and K. Liu, *Eur. J. Med. Chem.* 232 (2022) 114205

[2] T. Scattolin, V. A. Voloshkin, F. Visentin and S. P. Nolan, *Cell Reports Phys. Sci.* 2 (2021) 100446

[3] E. Bortolamiol, E. Botter, E. Cavarzerani, M. Mauceri, N. Demitri, F. Rizzolio, F. Visentin, T. Scattolin, *Molecules* 29 (2024) 345

## Employing of Functionalized Cellulose Nanocrystals with Waste Vegetable Oils for Sustainable Applications in Advanced Materials

Antonio Jiritano,<sup>a</sup> Vincenzo Algieri,<sup>b</sup> Federica Meringolo,<sup>a</sup> Paola Costanzo,<sup>a</sup> Loredana Maiuolo,<sup>a</sup> and Antonio De Nino<sup>a</sup>

<sup>a</sup> Department of Chemistry and Chemical Technologies – CTC, University of Calabria, Via P. Bucci, 87036 – Rende (CS), Italy

<sup>b</sup> IRCCS NEUROMED—Istituto Neurologico Mediterraneo, Via Atinense 18, 86077- Pozzilli (IS), Italy

E-mail: [antonio.jiritano@unical.it](mailto:antonio.jiritano@unical.it)

The increasing demand for sustainable and eco-friendly materials has driven research towards the utilization of renewable resources. Cellulose, the most abundant biopolymer on Earth, presents numerous advantages due to its biodegradability, biocompatibility, and remarkable mechanical properties [1]. Among the various forms of cellulose, nanocrystalline cellulose (NCC) stands out for its high surface area, unique optical properties, and ability to be functionalized, making it an ideal candidate for advanced material applications [2,3]. This study explores the innovative use of nanocrystalline cellulose functionalized with waste vegetable oils (WVO), in particular sunflower oil, to create a new sustainable material not only enhancing the hydrophobic properties of cellulose but also providing a valuable method for recycling a common waste product. This reaction is carried out according to the following scheme.

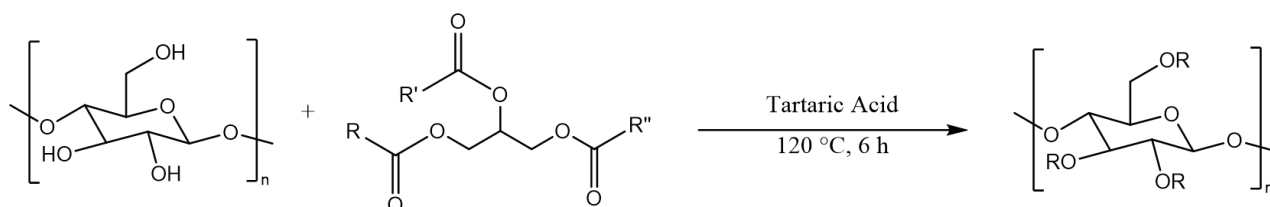

**Figure 1:** Reaction scheme between NCC and WVO.

This new material thus synthesized was also used to form composite materials, at 1%, 3%, 5% and 10% w/w, with the commercial polymer Ecovio®. The new composite material, made up by the polymer and the modified NCC, was filmed by solvent casting method and was evaluated how the use of this additive could influence the mechanical properties of the final material.

[1] K. N. Onwukamike, S.P. Grelier, E. Grau, H. Cramail, M.A. Meier, *ACS Sustainable Chem. Eng.*, 7, (2018), 1826–1840.

[2] M. Rajinipriya, M. Nagalakshmaiah, M. Robert, S. Elkoun, *ACS Sustain. Chem. Eng.*, 6 (2018), 2807–2828.

[3] L. Maiuolo, V. Algieri, F. Olivito, M.A. Tallarida, P. Costanzo, A. Jiritano, A. De Nino. *Catalysts*, 11, (2021), 96-135.

## Eco-friendly polyurethane resins: BHET-driven integration for end-of-waste solutions in a circular economy perspective

Gabriele Viada<sup>a</sup>, Simone Galliano<sup>a</sup>, Alberto Menozzi<sup>b</sup>, Federica Tammaro<sup>b</sup>, Claudia Barolo<sup>a,c</sup>, and Matteo Bonomo<sup>a</sup>

<sup>a</sup> *Department of Chemistry, NIS Interdepartmental Centre and INSTM Reference Centre, University of Turin, Via Gioacchino Quarello 15/a, 10135 - Torino, Italy*

<sup>b</sup> *Demak Polymers S.r.l., Corso Lombardia 44, 10099 - Torino, Italy*

<sup>c</sup> *ICxT Interdepartmental Centre, University of Turin, Lungo Dora Siena 100, 10153 - Torino, Italy*

E-mail: [gabriele.viada@unito.it](mailto:gabriele.viada@unito.it)

The enormous worldwide employment of single-use plastic materials is leading to ever-increasing waste generation. Therefore, the use of the latter as feedstock for the production of waste-derived materials has emerged as a hot topic within both the scientific community and the industrial area. However, to boost the creation of an effective and reliable market for secondary raw materials, an essential requirement for circular materials is the ease of implementation in current processes and products[1].

In this perspective, we have started to investigate bis(2-hydroxyethyl) terephthalate (BHET), a low molecular weight diol as the main product of the glycolysis of polyethylene terephthalate (PET), as a promising circular component in the formulation of more sustainable ready-to-market polyurethanes [2]. This approach is particularly appealing considering that the end-of-life of a preeminent thermoplastic polymer on a global scale (i.e. PET) would serve as feeding for the most prevalent thermosetting polymer worldwide [3] (i.e. PUs), thereby offering an alternative route for closing the loop on a not negligible portion of PET waste in an end-of-waste perspective.

In this contribution, we explored an innovative approach to implement BHET as a secondary raw material in the formulation of NCO-terminated prepolymer tailored for thermosetting resins. BHET was seamlessly integrated into the prepolymer formulation, avoiding any modifications to the industrial process and demonstrating outstanding compatibility with other components within the mixture. The impact of BHET concentrations and its relative ratio with polyether and polyester constituents of the prepolymer on the final resins were systematically evaluated, showcasing the feasibility of fine-tuning the physical, chemical, and mechanical properties of polyurethanes while preserving market-level properties. In conclusion, we proved the successful incorporation of a significant amount of BHET (up to 20% w/w) into novel, eco-friendly prepolymers using a solvent-free methodology, without necessitating additional steps in the industrial workflow.

[1] Bucknall, D.G., Philos. Trans. R. Soc. A (2020) 378, 2176.

[2] Mariotti, N., Viada, G., Galliano, S., Menozzi, A., Tammaro, F., Gianelli, W., Bonomo, M., Barolo, C., J. Clean. Prod. (2023) 408, 137161.

[3] <https://plasticseurope.org/knowledge-hub/plastics-the-facts-2022/>

This research acknowledges support from the Project CH4.0 under the MUR program “Dipartimenti di Eccellenza 2023–2027” (CUP D13C22003520001). GV acknowledges Decreto Ministeriale n. 1061 from MUR for funding the PhD scholarship.

## Turning Waste into High-Value Chemicals: Enhancing Plastic Waste Hydroconversion with a Novel Catalytic Approach

Viviana Bressi, Antonio Cosimo Pio Trimboli, Emilia Paone, Francesco Mauriello

<sup>a</sup> DICEAM Department, University Mediterranea of Reggio Calabria (UNIRC), Via Zehender, Loc. Feo di Vito 89123 Reggio Calabria

E-mail: [viviana.bressi@unime.it](mailto:viviana.bressi@unime.it)

Every year, approximately 380 million tonnes of plastic are produced globally, a significant portion of which becomes plastic waste. The United Nations Environment Programme (UNEP) reported in 2020 that only 9% of plastic waste is recycled and that the other 12% is burned [1]. The remaining 79% ends up in landfills or dispersed in the environment, contributing significantly to land and marine pollution. In this context, the hydroconversion of plastic waste represents a promising emerging technology. This process is crucial for transforming post-consumer plastic materials into high-value chemicals and fuels. Hydroconversion can occur through two main mechanisms: hydrocracking and hydrogenolysis. Hydrocracking involves breaking the chemical bonds in plastic by adding hydrogen in the presence of a catalyst, resulting in light hydrocarbon fractions such as gasoline and diesel [2]. Hydrogenolysis, conversely, involves cleavage of C–C and C–H bonds in polymer molecules using hydrogen, producing low molecular weight compounds and monomers [3]. The use of hydrogen donor solvents is a promising strategy to improve the efficiency of hydroconversion. These solvents can transfer hydrogen to plastic molecules, facilitating depolymerization and reducing the need for high-pressure hydrogen gas. This approach lowers operating costs and mitigates the risks associated with handling high-pressure hydrogen. Furthermore, hydrogen donor solvents can be selected and optimized to maximize the yield of desired products and minimize the formation of undesired byproducts.



**Figure 1:** Graphical Abstract

[1] P. G. C. Nayanathara Thathsarani Pilapitiya and A. S. Ratnayake, *Clean. Mater.* 11 (2024) 100220.

[2] L. Gao, X. Zhong, J. Liu, J. Chen, Z. Wang, Y. Zhang, D. Wang, M. Shakeri, X. Zhang and B. Zhang, *ChemSusChem* n/a e202400598.

[3] H. Nguyen-Phu, T. Kwon, T. Kim, L. Thi Do, K. Hyuk Kang and I. Ro, *Chem. Eng. J.* 475 (2023) 146076.

## Natural deep eutectic solvents for high-value products recovery from seafood industry waste

Federica Mancarella,<sup>a</sup> Paola Semeraro,<sup>a</sup> Francesco Milano,<sup>b</sup> Livia Giotta,<sup>a</sup> and Ludovico Valli<sup>a</sup>

<sup>a</sup> *Dipartimento di Scienze e Tecnologie Biologiche ed Ambientali, Università del Salento, S.P. Lecce-Monteroni, 73100 Lecce, Italy.*

<sup>b</sup> *Istituto di Scienze delle Produzioni Alimentari (ISPA), Consiglio Nazionale delle Ricerche (CNR), S.P. Lecce-Monteroni, 73100 Lecce, Italy.*

E-mail: [federica.mancarella@unisalento.it](mailto:federica.mancarella@unisalento.it)

Recovering waste biomass is crucial for the transition to a circular economy. A better management of seafood waste is needed to reduce the environmental impact of its disposal and, at the same time, to have full use of the biomass for high-value commercial purposes. In this context, discarded shells of red shrimps (*Aristaeomorpha foliacea*), provided by a local seafood company, were employed as a source of astaxanthin (AXT), a xanthophyll with multiple health-promoting properties [1] and chitin, a biopolymer precursor of chitosan, widely used in various applications. To meet sustainability requirements at every stage of the recovery process, conventional solvents and chemical agents were replaced by Natural Deep Eutectic Solvents (NADES) [2]. For AXT extraction, a hydrophobic NADES based on menthol and decanoic acid at 1:1 molar ratio was successfully employed. The influence of several parameters and operating conditions was investigated and the bioactivity of AXT extracts was assessed by measuring the Trolox equivalent antioxidant capacity (TEAC). Moreover,  $\alpha$ -cyclodextrin was used as emulsifying agent for preparing NADES/water emulsions, which proved to greatly enhance the chemical stability of dispersed AXT, thus laying the foundation for the development of an AXT formulation suitable to be tested by in vitro toxicity and bioactivity assays. In addition, a hydrophilic NADES based on choline chloride and lactic acid at 1:1 molar ratio was employed to isolate chitin from the AXT extraction residues. This NADES proved to fully dissolve calcium carbonate and remove a certain amount of proteins from the chitin fibers, thus enabling the one-pot purification of raw chitin with no needing of mineral acids and strong bases.

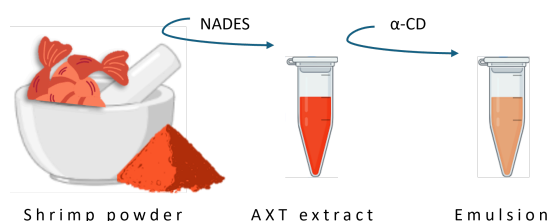

**Figure 1:** Astaxanthin extraction and preparation of NADES/water emulsions.

[1] Donoso A., Gonzalez-Durán J., Agurto Muñoz A., et al., *Pharmacological Research*, 166 (2021), DOI 10.1016/j.phrs.2021.105479

[2] Hamdi Zainal-Abidin M., Hayyan M., Hayyan A., Jayakumar N. S., *Analytica Chimica Acta*, 979 (2017), 1-23, DOI 10.1016/j.aca.2017.05.012.

## Hydrophobic eutectic solvents in water remediation

Chiara Carotti, Arianna Rossetti, Laura Riva, Alberto Mannu, Grazia Isa Carla Righetti, Francesco Briatico Vangosa, Carlo Punta, Andrea Mele, and Maria Enrica Di Pietro

Department of Chemistry, Materials and Chemical Engineering "G. Natta", Politecnico di Milano, Via Mancinelli 7, 20131, Milan, Italy

E-mail: chiara.carotti@polimi.it

Water is essential for human survival, but only 40% of surface water bodies currently have a "good ecological status", highlighting the need for effective water pollution monitoring and remediation technologies [1]. Existing methods for removing industrial contaminants of emerging concern (ICECs) often use toxic solvents and unsustainable sorbents.

The POSEIDON project (hydroPhObic eutectic SolvEnts In water remeDiation) aims to develop sustainable extractants using Hydrophobic Eutectic Solvents (HES) combined into Hydrophobic EutectoGels (HEG) [2] and HES-loaded Cellulose nanoSponges (HECS) [3]. The used type V HESs are created by mixing two non-ionic components derived from renewable sources, with promising properties and significant economic and environmental benefits.

The project involves a screening phase where pH, viscosity, density, and leaching properties are analyzed for the selected HESs. The most effective HESs are then gelled with DBS and utilized in dispersive liquid-liquid and solid-liquid microextraction of ICECs. Preliminary results focus on the removal of the phenolic contaminant bisphenol A from model samples of contaminated water. UV-Vis and NMR spectroscopy are employed to quantify BPA in aqueous and HES phase, respectively.

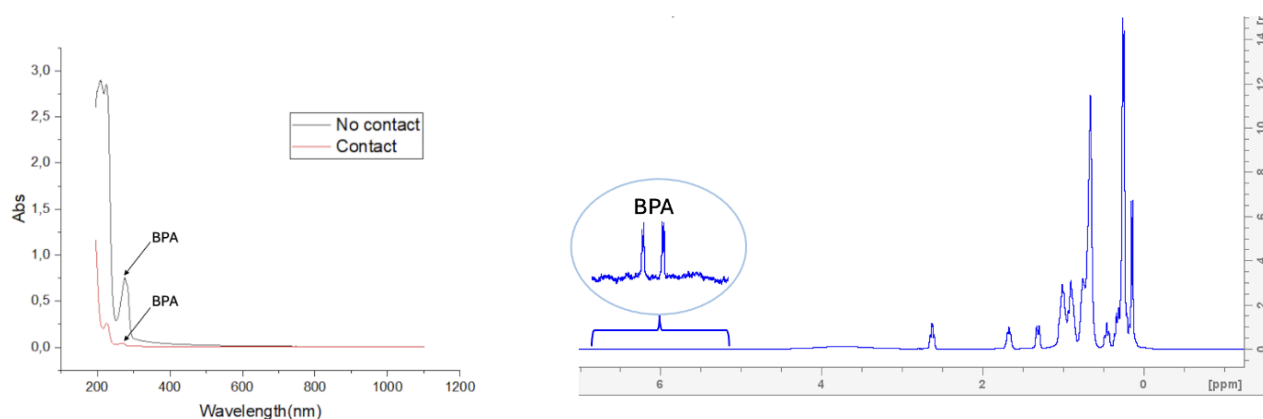

Acknowledgement: this work has been funded by European Union – Next Generation EU in the framework of the PRIN 2022 PNRR project POSEIDON – P2022J9C3R

[1] EU Commission, Water, [https://environment.ec.europa.eu/topics/water\\_en](https://environment.ec.europa.eu/topics/water_en)

[2] G. de Araujo Lima e Souza, M. E. Di Pietro, A. Mele, *RSC Sustainability*, **2**, 288-319, (2024)

[3] L. Melone, B. Rossi, N. Pastori, W. Panzeri, A. Mele, C. Punta, *Chempluschem*, **80**, 1408-1415, (2015)

## Exploring the potential of soft calcite: innovative solutions for sustainable engineering

Martina Carcagni,<sup>a</sup> Paola Semeraro,<sup>b</sup> Matilda Mali,<sup>a</sup> Rossella Petti,<sup>a</sup> Claudia Vitone,<sup>a</sup> and Livia Giotta<sup>b</sup>

<sup>a</sup> *Department of Civil, Environmental, Land, Building Engineering and Chemistry (DICATECh) Politecnico di Bari, E. Orabona n. 4, 70126 - Bari, Italy*

<sup>b</sup> *Department of Biological and Environmental Sciences and Technologies (DiSTeBA), Università del Salento, via Lecce-Monteroni, 73100 - Lecce, Italy*

*E-mail: m.carcagni@phd.poliba.it*

The sustainable use of resources is a key issue in a global trend where the demand for them increases exponentially to support ongoing economic and social growth. This requires new strategies that must focus on transforming waste into recycled products for other applications. Inspired by the circular economy concept, this approach can be extended to different fields, including the management and reuse of marine wastes like sediments, periodically dredged in port areas (in Europe about 100-200 million m<sup>3</sup>/year), or seafood industry wastes (reached a production record of 214 million tonnes in 2020) [1]. Europe is the second worldwide bivalve producer and discarded shells represent more than half of the fish-product mass, with high disposal costs and considerable environmental impacts. A proper valorization of its residues would decrease the ocean contamination and improve the sustainable management of marine resources. In line with these concepts, we are exploring the potential of mussel shells waste as a valuable raw material to be biorefined and added to marine sediments, to find out novel eco-friendly solutions that can be used in construction for a sustainable engineering. Improving an existing protocol [2], this contribution explores the intriguing properties of a peculiar form of calcium carbonate, known as “soft calcite”, obtained from Mediterranean mussel shells by controlled dissolution of the aragonite component. This material proved to possess a high specific surface, as shown by morphological analyses, resulting in interesting adsorption capability and can be used as a substitute for other high impact and non-renewable materials, for example in building materials. Heat treated mussel shells reduced into fine powder are already used as partial substitute for binders to mechanically and/or chemically stabilize fine grained marine sediments [3]. Here we propose the mixing of the dredged sediments in their natural state with different amounts of hydraulic binders and soft calcite powder, that partially replaces the binder in the mixture, to obtain new building materials with good mechanical properties.

[1] FAO. *The State of World Fisheries and Aquaculture 2022. Towards Blue Transformation*. Rome, (2022)

[2] J. N. Murphy, C. M. Schneider, K. Hawboldt and F. M. Kerton, *Matter* 3, 6 (2020) 2029-2041

[3] R. Petti, C. Vitone, M. I. Marchi, M. Plötze and A. Puzrin, *Géotechnique* (2024) 1-20

**Study of antifouling hydrophobic coatings via contact angle measurements**

Viviana Nebbioso<sup>a</sup>, Immacolata Climaco<sup>a</sup>, Paola Amato<sup>a</sup>, Claudio Imparato<sup>a</sup>, Aurelio Bifulco<sup>a</sup>, Silvia Roscioli<sup>b</sup>, Amedeo Amoresano<sup>b</sup>, and Antonio Aronne<sup>a</sup>

<sup>a</sup>*Department of Chemical, Materials and Production Engineering, University of Naples Federico II, Piazzale V. Tecchio 80, I-80125 Naples, Italy*

<sup>b</sup>*Department of Industrial Engineering, University of Naples Federico II, Via Claudio 21, I-80125 Naples, Italy*

*E-mail: viviana.nebbioso@unina.it*

Marine biofouling is a problem affecting maritime industries. This phenomenon consists in the growing and accumulation of micro and macroorganism on the immersed surface belonging to the boats. The development of marine fouling can have a negative impact on the hydrodynamics of the ship and on the environment. It leads on one side to an increase of fuel consumption (up to 40%) with greater emissions of CO<sub>2</sub>, NO<sub>x</sub> and SO<sub>x</sub>, causing an increase of fine dust, acid rains and health implications, and on the other it causes significant financial as well as energy efficiency losses<sup>1</sup>. Increasing restrictions in the use of biocides are being introduced, requiring alternative and more sustainable solutions to be developed. One of these is a novel polymer-based antifouling coating formed by an epoxy matrix filled with a proper designed sol-gel hybrid material. The polymeric formulations contain hybrid TiO<sub>2</sub>-based nanoparticles, in which Ti<sup>4+</sup> ions are involved in coordinative bonds with an organic bio-waste allowing the formation and stabilization of reactive oxygen species (ROS) on the surfaces. Moreover, this hybrid material is functionalized with hydrophobic silanes able to confer very low wettability to the coatings<sup>2</sup>. Surface hydrophobicity is a fundamental property crucial to inhibit marine biofouling formation because this kind of surface is characterized by low surface energy and shows weak interactions with biomolecules allowing an easier removal of the biofouling<sup>3</sup>. Herein, we evaluated the tilting angle and contact angle hysteresis of epoxy samples made using silanized hybrid TiO<sub>2</sub>-based nanoparticles as filler to deeper investigate their surface properties and consequent suitability to be applied as coatings.

These parameters were measured for several formulations by the means of a professional camera with 1,3-megapixel resolution and frame rates up to 80000 fps. Preliminary results demonstrate that all the formulations guarantee surfaces exhibiting a certain degree of hydrophobicity. Indeed, tilting angles are between 11 and 17 degrees, while hysteresis angles fall within 40 and 60 degrees. Future activities will be devoted to the study of the dynamic behavior related to the water drops on the coatings and the evaluation of their effectiveness in inhibiting the adhesion and proliferation of marine biofouling.

[1] H. Qiu, et al., *Prog. Polym. Sci.*, 2022, 127, 101516.

[2] A. Bifulco, et al., *Chem. Eng. J.*, 2024, 484, 149327.

[3] Leonardi, et al., *Annu. Rev. Chem. Biomol. Eng.*, 2019, 10, 241-264.

## Double cascade sequential highly diastereoselective [3+3] spirocyclization for the synthesis of 3-spiropiperidine heterocycles

Mohammad Sadeq Mousavi, Antonia Di Mola, and Antonio Massa

Dipartimento di Chimica e Biologia "A. Zambelli" Università degli Studi di Salerno, Via Giovanni Paolo II, 84084-Fisciano (SA) (Italy)

E-mail: [semousavi@unisa.it](mailto:semousavi@unisa.it)

We present a novel approach for synthesizing hybrid 3-spiropiperidines that feature 3-isochromanone and 3-isindolinone groups [1]. This is achieved through a one-pot double cascade reaction using an affordable K<sub>2</sub>CO<sub>3</sub>/TBAB catalytic system. By examining the nucleophilicity of lactone 3-isochromanone [2], we developed a sequence of cascade reactions to initially create a bi-nucleophilic hybrid isochromanone-isindolinone platform. This is followed by a [3+3] spirocyclization with  $\alpha,\beta$ -unsaturated aldehydes. Notably, the regioselectivity of the spirocyclization is significantly influenced by the substitution pattern on the lactam ring of the platform. The resulting products exhibit high diastereoselectivity, even with the formation of 3 or 4 stereocenters, and feature two contiguous quaternary carbons. The sequential cascade reactions were also successfully scaled up, and the reactivity of the products was readily analyzed, allowing for the transformation of existing functional groups into new, attractive functionalities [3].

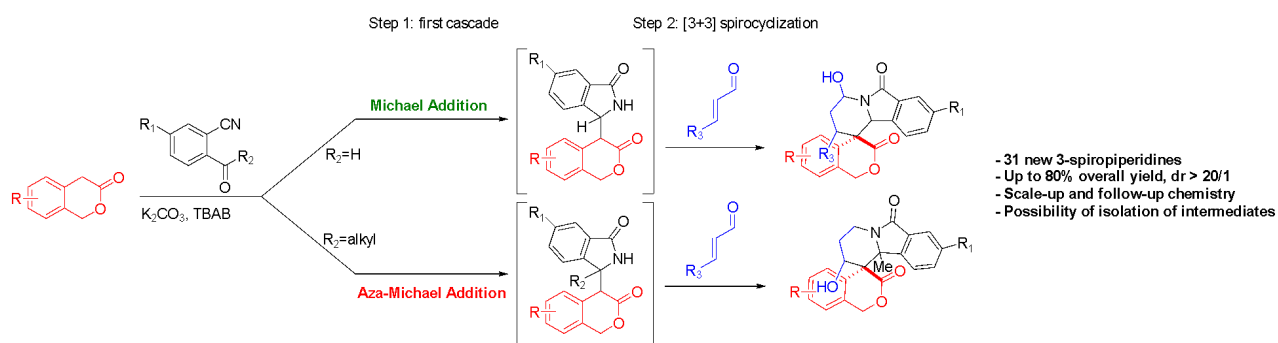

[1] "Multifaceted Behavior of 2-Cyanobenzaldehyde and 2-Acybenzonitriles in the Synthesis of Isoindolinones, Phthalides and Related Heterocycles" M. S. Mousavi, A. Di Mola, A. Massa, *Eur. J. Org. Chem.* **2023**, 26, 202300289.

[2] Mousavi, M. S.; Di Mola, A.; Pierri, G.; Tedesco, C.; Hensinger, M. J.; Sun, A.; Wang, Y.; Mayer, P.; Ofial, A. R.; Massa, A. *J. Org. Chem.* **2024**, 89, 6915-6928.

[3] K. Hiesinger, D. Darin, E. Proschak, M. Krasavin *J. Med. Chem.* **2021**, 64, 150–183 Spirocyclic Scaffolds in Medicinal Chemistry.

## Investigating the interactions between salphen metal complexes and RNA/DNA G-quadruplexes through experimental and computational methods

Luisa D'Anna,<sup>a</sup> Ugo Perricone,<sup>b</sup> Angelo Spinello,<sup>a</sup> Antonio Monari\*,<sup>c</sup> Giampaolo Barone\*,<sup>a</sup> and Alessio Terenzi\*<sup>a</sup>

<sup>a</sup> *Dipartimento di Scienze e Tecnologie Biologiche, Chimiche e Farmaceutiche, Università degli studi di Palermo, Viale delle Scienze 17, 90128-Palermo, Italia*

<sup>b</sup> *Fondazione Ri.MED, Via Filippo Marini 14, 90128, Palermo, Italia*

<sup>c</sup> *Université Paris Cité and CNRS, ITODYS, F-75006 Paris, France*

E-mail: [luisa.danna@unipa.it](mailto:luisa.danna@unipa.it)

Over the past decade, there has been significant advancement in the development of DNA-targeting drugs, particularly those designed to selectively bind non-conventional DNA motifs. G-rich sequences in DNA and RNA, for instance, can form four-stranded structures known as G-Quadruplexes (G4s), which are composed of stacked guanine tetrads. These structures are enriched in highly conserved sequences and are strategically located within human and viral genomes, making them attractive targets for anticancer and antiviral drugs [1]. RNA and DNA viruses contain putative guanine quadruplex sequences. Using a combination of computational and experimental methods, our research group has successfully predicted two SARS-CoV-2 G4 structures, named RG-1 and RG-2 [2]. Schiff base ligand metal complexes can selectively bind G4 structures due to their unique chemical and structural properties [3]. We have synthesized novel metal complexes with asymmetrical Salphen ligands, incorporating both neutral and charged substituents, and tested their selectivity towards viral and human G4s in aqueous solutions using spectroscopic and computational approaches (Figure 1). Preliminary results indicate that these asymmetric complexes have a promising ability to selectively bind RNA and DNA G4 structures. Ongoing studies are focused on investigating the biological activity of our asymmetric Schiff base metal complexes.

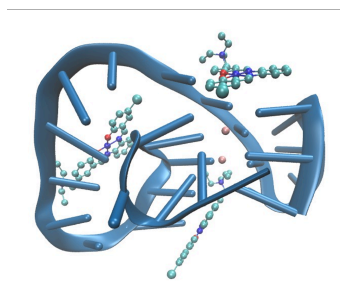

**Figure 1.** Possible binding poses of asymmetric salphen metal complexes and G4.

[1] D.Varshney, J.Spiegel, K.Zyner, D.Tannahill, S.Balasubramanian, *Nat Rev Mol Cell Biol.* Ed. 21 (2020), 459.

[2] L.D'Anna, T.Miclot, E.Bignon, U.Perricone, G.Barone, A.Monari A.Terenzi, *Chem. Sci.* Ed.43 (2023), 11332-11339. Featured on The Journal Cover.

[3] L.D'Anna, S.Rubino, C.Pipitone, G.Serio, C.Gentile, A.Palumbo Piccionello, F.Giannici, G.Barone, A.Terenzi, *Dalton Trans.* Ed. 52 (2023), 2966.

## Reusable acrylic-based smart polymers for textile dye extraction

Marta Guembe-García,<sup>a</sup> Alba Torija-López,<sup>a</sup> Gianluca Utzeri,<sup>b</sup> Artur José Monteiro Valente,<sup>b</sup> Saturnino. Ibeas,<sup>a</sup> Miriam Trigo-López,<sup>a</sup> José Miguel García,<sup>a</sup> and Saul Vallejos<sup>1</sup>.

<sup>a</sup> Departamento de Química, Facultad de Ciencias, Universidad de Burgos, Plaza Misael Bañuelos s/n, 09001 Burgos, Spain.

<sup>b</sup> Department of Chemistry, University of Coimbra, 3004-535 Coimbra, Portugal  
E-mail: mguembe@ubu.es

Water pollution caused by industrial or domestic waste, which contains dyes from the textile industry, represents a significant environmental problem today [1].

In this work, we have developed a smart cross-linked polymer film made from 2-(dimethylamino) ethyl methacrylate copolymerized with other commercial monomers, capable of adsorbing 21 textile dyes from different families. The interaction of the material with the dye allows it to be removed from the aqueous medium (Fig. 1) with an extraction percentage higher than 90%. The behavior of the material was studied using UV-Vis spectroscopy, employing pseudo-first-order and Crank-Dual models [2]. Permeation and fluorescence analyses, among others, supported the previous results.

Furthermore, the proof of concept demonstrated the resistance of the smart material to common softeners and detergents without compromising its adsorption capacity. Additionally, the material is reusable (for at least 5 cycles) and exhibited durability and good thermal and mechanical properties, confirming its stability and suitability for industrial applications.

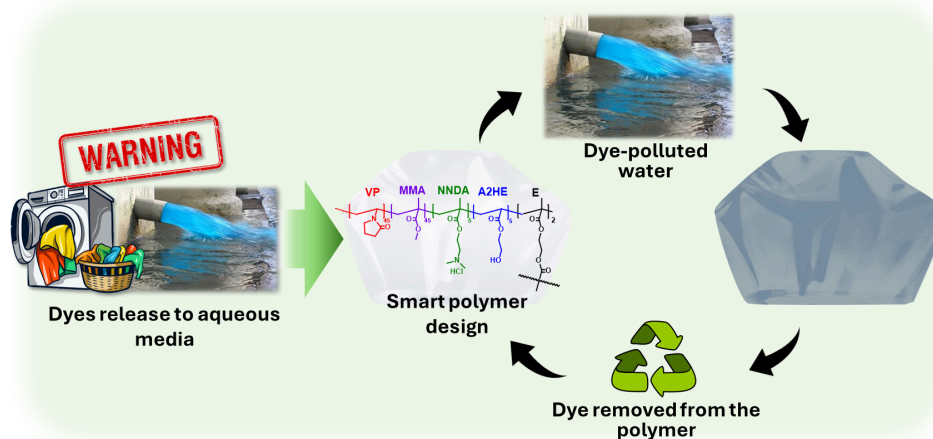

**Figure 1:** Diagram of the material's behavior.

[1] D. Cao, K. Niu, F. Yu, *Advanced Materials Research*. 332 1087–1092 (2011).

[2] M. Guembe-García, P.D. Peredo-Guzmán, V. Santaolalla-García, N. Moradillo-Renuncio, S. Ibeas, A. Mendía, F.C. García, J.M. García, S. Vallejos, *Polymers (Basel)* 12 (6) 1249 (2020).

---

## FL031

### EXPOASMA: pollution, oxidative stress and exposome

Chiara Maccari,<sup>a,b</sup> Paola Mozzoni,<sup>a,b</sup> Massimo Corradi,<sup>a,b</sup> Silvana Pinelli,<sup>a</sup> and Roberta Andreoli<sup>a,b</sup>

<sup>a</sup> *Laboratory of Industrial Toxicology and Advanced Analytical Methods, Department of Medicine and Surgery, University of Parma*

<sup>b</sup> *Center of Excellence for Toxicological Research (CERT), University of Parma, Via Gramsci 14, 43126 Parma, 10 Italy*

E-mail: [chiara.maccari@unipr.it](mailto:chiara.maccari@unipr.it)

Asthma is one of the most common respiratory diseases in the world, with an estimated 300 million asthmatic patients of all ages, to understand the role of pollution in the development of asthma it is necessary to evaluate and quantify biomarkers of dose and effect in the biological matrices of exposed subjects, as well as the role of polymorphisms of biotransformation enzymes as determinants of individual susceptibility. In order to studies this, in healthy and asthmatic volunteers a spot urine sample and buccal brush sample were collected. Urinary levels of Benzene, Toluene, Ethylbenzene and Xylenes (BTEX), Styrene and Methyl-tert-butylether (MTBE) have been quantified to assess environmental exposure by GC-MS, the nucleic acids damage, as biomarker of effect, have been quantified by LC-MS/MS and HMGB1 have been determined in urine with enzyme-linked immunosorbent assay [1].

The LC analysis was done with ExcionLC (sciex), the separation was performed by C18 column in elution gradient, coupled by 6500+ (sciex) and the analysis was conducted in positive mode for metabolite and negative mode for oxidative nucleic acid; GC analysis was performed by SPME extraction to quantified low concertation of pollutant. Positive correlations between DHBMA and 5MeCyt are observed, which are equal to 0.655 for healthy subjects ( $p < 0.01$ ) and 0.575 for asthmatic subjects ( $p < 0.01$ ).

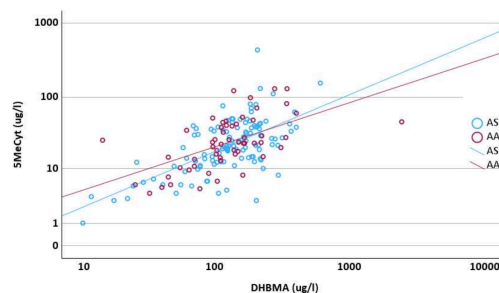

**Figure 1:** Correlation between DHBMA/5-MeCyt.

The correlation between inflammation and exposure could help in the personalized treatment of asthma, aiming to achieve a better quality of life for people with respiratory diseases [2].

[1] Abboud, M. M., Al-Rawashde, F. A., & Al-Zayadneh, E. M. (2022). *Journal of Asthma*, 59(11).

[2] Bellou, V., Gogali, A., & Kostikas, K. (2022). *n Journal of Personalized Medicine* (Vol. 12, Issue 8)

## True-to-life nanomaterials for evaluating nanoplastics impacts on human health

Serena Ducoli,<sup>a</sup> Stefania Federici,<sup>a</sup> Miriam Romano,<sup>b</sup> Andrea Zandrini,<sup>b</sup> Paolo Bergese,<sup>b</sup> and Laura Eleonora Depero,<sup>a</sup>

<sup>a</sup> *Department of Mechanical and Industrial Engineering, University of Brescia, Via Branze 38, 25123-Brescia, Italy and INSTM*

<sup>b</sup> *Department of Molecular and Translational Medicine, University of Brescia, Viale Europa 11, 25123-Brescia, Italy and CSGI*

E-mail: [serena.ducoli@unibs.it](mailto:serena.ducoli@unibs.it)

Environmental nanoplastic pollution is a great issue affecting all ecosystems. The need to understand the possible implications of nanoplastic pollution on the environment and human health is becoming increasingly pressing. Given the complexity of separating nanoplastics from environmental samples, studies have been so far conducted using synthetic polystyrene nanobeads (NBs). There is an urgent need to create nanomaterials that better reflect the real characteristics of nanoplastics naturally formed, viz. true-to-life nanoplastics (T2LNPs), to close the gap between the laboratory parameters and the rules of nature, and to provide more realistic understandings of the characteristics of nanoplastics [1,2].

Here, we present a study on the production and characterization of T2LNPs from daily-used plastics, the investigation of bio-interfaces through the study of protein corona formation on T2LNPs with respect to synthetic NBs, and the assessment of their toxicity of human cells. T2LNPs samples were produced from daily life plastic items subjected to mechanical fragmentation through an ultracentrifugal mill operating in cryogenic conditions. The produced T2LNPs were characterized by FTIR spectroscopy to investigate their chemical nature and check the absence of induced chemical modifications. Morphology and size distribution analyses were performed through AFM and SEM. Finally, the protein corona formation from human plasma on T2LNPs and NBs was examined by electrophoresis and in-vitro toxicity at different exposure time and concentrations was assessed through MTT assay.

[1] S. Ducoli, S. Federici, R. Nicsanu, A. Zandrini, C. Marchesi, L. Paolini, A. Radeghieri, P. Bergese and L.E. Depero, *Environ. Sci.: Nano*, 9 (2022) 1414-1426

[2] S. Ducoli, S. Federici, M. Cocca, G. Gentile, A. Zandrini, P. Bergese and L.E. Depero, *Environ. Environmental Pollution*, 343 (2024) 123150

## Exploring adsorption technologies for cattle enteric CH<sub>4</sub> capture: from data collection to process simulation

Alice Gramegna,<sup>a</sup> Matteo Tommasi,<sup>a,b</sup> Simge Naz Degerli,<sup>a</sup> Daniela Lovarelli,<sup>c</sup> Laura Prati,<sup>b</sup> Marcella Guarino,<sup>c</sup> and Ilenia Rossetti,<sup>a,b</sup>

<sup>a</sup> *INSTM Unit Milano-Università, Via C. Golgi 19, 20133 Milan, Italy*

<sup>b</sup> *Department of Chemistry, Università degli Studi di Milano, Via C. Golgi 19, 20133 Milan, Italy*

<sup>c</sup> *Department of Environmental Science and Policy, Università degli Studi di Milano, Via Celoria 2, 20133 Milan, Italy*

E-mail: [alice.gramegna@guest.unimi.it](mailto:alice.gramegna@guest.unimi.it)

Ruminants, mainly dairy cattle, account for about one third of the global anthropogenic methane emissions. Considering that a cow emits about 500 L/d of methane [1] and in view of the increasing population of cows due to the intensive farming activities, the daily methane emission is considerable and is likely to further increase. Our project focuses on exploring adsorption technologies to mitigate the environmental impact of zootechnical facilities. Preliminary samples collected using characterized activated carbons have been analyzed through TPD analysis. We identified two major challenges: capturing methane at low partial pressures and competitive adsorption due to higher CO<sub>2</sub> concentration in cattle barns, which favors CO<sub>2</sub> uptake over methane. The design work, performed using Aspen Adsorption<sup>®</sup> V11, revealed the necessity of a two-stage adsorption system, as shown in Fig. 1. An initial “guard bed” is used to adsorb carbon dioxide and other gases from the barn, while efficiently adsorbing methane in the second bed. The plant has been optimized for continuous GHGs removal and sized appropriate for construction near cattle barns. The choice of an adsorption-based system was influenced by its cost-effectiveness, scalability and the abundant supply of adsorbent materials.

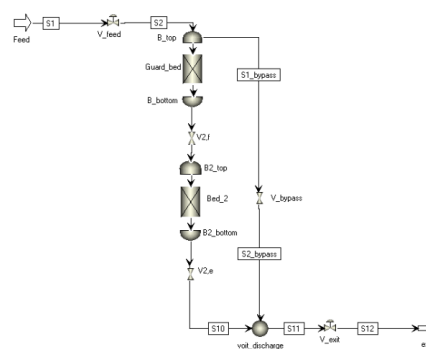

**Figure 1:** Simulated flowsheet for GHGs capture. Aspen Adsorption<sup>®</sup> V11.

This study was carried out within the Agritech National Research Center, Next-GenerationEU (PIANO NAZIONALE DI RIPRESA E RESILIENZA (PNRR) – MISSIONE 4 COMPONENTE 2, INVESTIMENTO 1.4 – D.D. 1032 17/06/2022, CN00000022), WPs 8.3.2 and 8.4.1.

[1] K. A. Johnson and D. E. Johnson, *J. Anim. Sci.* 73 (1995) 2483–2492.

## Exploiting indoor light: Improving dye-sensitized solar cells for low light photovoltaics

Giorgia Salerno<sup>a,b</sup>, Daniele Franchi<sup>c</sup>, Alessio Dessì<sup>c</sup>, Norberto Manfredi<sup>a</sup>, Ottavia Bettucci<sup>a,\*</sup>, Alessandro Abbotto<sup>a,\*</sup>

<sup>a</sup> Dipartimento di Scienza dei Materiali, Università degli Studi di Milano-Bicocca, Via R. Cozzi 55, 20125 Milano, Italy.

<sup>b</sup> Dipartimento di Informatica e Matematica Applicata (DIEM), Università degli Studi di Salerno, Invariante 12/B, Via Giovanni Polo II, 132 I-84084, Fisciano, Salerno, Italy

<sup>c</sup> Institute of Chemistry of Organometallic Compounds (CNR-ICCOM), Sesto Fiorentino, 50019, Italy

E-mail: giorgia.salerno@unimib.it

Today, energy is mainly derived from fossil fuels, such as coal, oil, and natural gas. These non-renewable fuels, when burned, release large amounts of carbon dioxide into the atmosphere, contributing significantly to climate change. The response to climate change is an urgent energy transition to renewable energy sources, with solar energy being the most promising one. Dye-Sensitised Solar Cells (DSSCs) are among the latest generation of solar cells. These cells offer a promising technology for indoor applications due to their ability to work effectively with diffuse and low-intensity light. Indeed, DSSC are particularly useful for powering small devices, such as remote controls for lights, light and temperature sensors, that are part of the Internet of Things. The light spectrum of indoor lamps is significantly different from the solar spectrum. Therefore, it is crucial that the dye photosensitizer designed for indoor photovoltaics has an absorption spectrum that well overlaps with the higher-emission areas of the lamps. The dyes used in this research work have a D- $\pi$ -A structure which, thanks to the variety of the organic units, allows an optimal matching to the different indoor lamps. We synthesised and tested four metal-free organic dyes with different and complementary optical properties, able to adapt to the different emission spectra of the lamps. The absorption spectra of the dyes were superimposed on the emission spectrum of two indoor lamps, a 2700K (warm) and 6400K (cold) neon lamp. Preliminary results have confirmed our hypotheses thus allowing increased power conversion efficiencies in combination with the different lamps. [1]

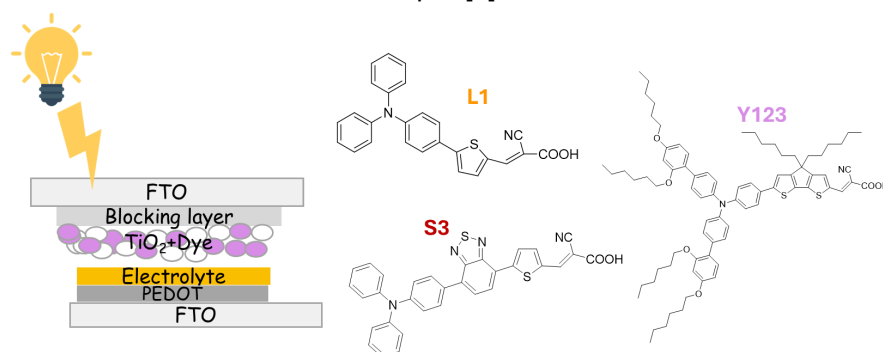

[1] G.Salerno, B. Cecconi, O. Bettucci, M. Monai, L. Zani, D. Franchi, M. Calamante, A.Mordini, T. Montini, P. Fornasiero, N. Manfredi, and A. Abbotto. *Eur. J. Org. Chem.* 26 (2023) 45

**Exploring the effect of different synthetic routes on the electrocatalytic activity of LaNiO<sub>3</sub> towards the oxygen evolution reaction**

Giorgio Pagano, Leonardo Duranti, Anna Paola Panunzi, and Elisabetta di Bartolomeo

*Department of Chemical Science and Technologies, Università degli Studi di Roma "Tor Vergata", Via della Ricerca Scientifica 1, 00133 Rome, Italy**E-mail: [giorgio.pagano@uniroma2.it](mailto:giorgio.pagano@uniroma2.it)*

Hydrogen gas (H<sub>2</sub>) is mostly produced through methane reforming (grey hydrogen), a process that also generates CO<sub>2</sub> as a byproduct [1]. Although water electrolysis is a more environmentally friendly way of producing H<sub>2</sub> (green hydrogen), high costs and energy requirements prevent its widespread usage [2]. The overall kinetics of the water splitting reaction is limited by the oxygen evolution reaction (OER), which requires expensive, highly scarce platinum group metal (PGM) electrocatalysts such as IrO<sub>2</sub> and RuO<sub>2</sub> [2,3]. An alternative to PGM-based materials is provided by perovskite oxides (ABO<sub>3</sub>), mixed metal oxides with a high degree of structural tunability, remarkable stability and low costs [2,3]. Lanthanum nickelates are especially promising due to their good electrical conductivity and their ability to form a highly OER active NiOOH layer through surface reconstruction [2,3].

In this work, LaNiO<sub>3</sub> perovskite was synthesized with two wet synthesis methods (coprecipitation and solution combustion synthesis) to investigate the relationship between synthesis route and electrocatalytic activity. Phase purity was assessed via X-ray diffraction while specific surface area was obtained from N<sub>2</sub> adsorption isotherms. The electrochemically active surface area (ECSA) was calculated from double layer capacitance (C<sub>dl</sub>) measurements, activity towards OER was determined via cyclic voltammetry (1.0-1.7 V vs RHE) as well as Tafel plots and electrochemical impedance spectroscopy (EIS).

[1] P. Nikolaidis, and A. Poullikkas, *Renew. and Sustain. Energy Rev.* 67 (2017) 597-611

[2] J. A. Dias, M. A. S. Andrade, H. L. S. Santos, M. R. Morelli, and L. H. Mascaro, *ChemElectroChem*, 7 (2020) 3173.

[3] C. E. Beall, E. Fabbri, and T. J. Schmidt *ACS Catal.* 11 (2021) 3094-3114.

## Synthesis and characterization of a non-stoichiometric perovskite oxide $\text{La}_{0.4}\text{Ca}_{0.4}\text{TiO}_3$ as fuel electrode for solid oxide cells (SOC)

Michela Cornale, Anna Paola Panunzi, Leonardo Duranti, and Elisabetta di Bartolomeo

*Dipartimento di Scienze e Tecnologie Chimiche, Università degli Studi di Roma "Tor Vergata", Via della  
Ricerca Scientifica 1, 00133, Roma, Italia  
michela.cornale@uniroma2.it*

High Temperature SOCs are among the most interesting devices for energy storage and conversion. SOCs offer high energy efficiency due to the high working temperature (>650°C), which favors thermodynamics and kinetics. The electrode state-of-art materials are perovskite oxides, those containing Fe at the B-site display mixed ionic-electronic conductivity and catalytic activity but poor stability in reducing environment. Among the various perovskite systems, titanates (Ti at B-site) have attracted particular interest due to high structural stability in reducing atmosphere but show low ionic conductivity and electrocatalytic activity [1].

This study presents the synthesis and characterization of an A-site deficient, B-site Ni-doped titanate perovskite  $\text{La}_{0.4}\text{Ca}_{0.4}\text{Ti}_{0.95}\text{Ni}_{0.05}\text{O}_3$  (LCTN). The A-site deficiency leads to an increase in oxygen vacancies as compared to the stoichiometric compound, which increase the ionic conductivity. Meanwhile, the Ni doping can improve the electrocatalytic activity also due to exsolution phenomenon [2].

Different synthesis routes are presented. LCTN is characterised by X-Ray Diffractometry (XRD) to identify crystalline structure, study the textural properties and assess its structural stability after reduction. Scanning Electron Microscopy (SEM) is used to evaluate the exsolution. The electrical conductivity in hydrogen is reported. Finally, the electrochemical properties are evaluated by assessing the electrode Area Specific Resistance (ASR) on symmetrical cells.

[1] J. J. Alvarado Flores, M. L. Ávalos Rodríguez, G. Andrade Espinosa, and J. V. Alcaraz Vera, *International Journal of Hydrogen Energy* 44 (2019) 12529-12542

[2] W. Fan, Z. Ren, Z. Sun, X. Yao, B. Yildiz, and J. Li, *ACS Energy Lett.* 7 (2022) 1223–1229

## Novel PET hydrolases derived from thermophilic microorganisms

Martina D'Auria,<sup>a</sup> Romualdo Troisi,<sup>a</sup> Andrea Bosso,<sup>b</sup> Rosanna Culurciello,<sup>b</sup> Andrea Strazzulli,<sup>b,c</sup> Marco Moracci,<sup>b,c</sup> Elio Pizzo,<sup>b</sup> and Filomena Sica,<sup>a</sup>

<sup>a</sup> Department of Chemical Science, Università degli studi di Napoli "Federico II", Via Vicinale Cupa Cintia, 26, 80126 Napoli, Italy

<sup>b</sup> Department of Biology, Università degli studi di Napoli "Federico II", Via Vicinale Cupa Cintia, 26, 80126 Napoli, Italy

<sup>c</sup> NBFC, National Biodiversity Future Center, Piazza Marina, 61, 90133, Palermo, Italy

E-mail: [martina.dauria@unina.it](mailto:martina.dauria@unina.it)

Plastics have become ubiquitous in our daily life, due to their significant properties. However, the nature of the polymers constituting plastic materials makes them persistent in the environment. The resulting growth in the quantity of plastics waste has emerged as a pressing issue [1]. In recent years, biodegradation approaches have demonstrated valuable potential in degrading plastics through the action of enzymes, bringing low environmental impact [2]. In 2016, a bacterial strain called *Ideonella sakaiensis* 201-F6 was identified for its abilities to produce two unique enzymes, the polyethylene terephthalate hydrolase (PETase) and the mono (2-hydroxyethyl) terephthalic acid hydrolase (MHETase). These enzymes enable the bacteria to utilize polyethylene terephthalate (PET) as their sole carbon source [3]. In this scenario, extensive research has been carried out for the identification of other bacterial strains able to produce enzymes exploitable for the plastic degradation [1].

Starting from these bases, the identification of new bacterial hydrolases deriving from thermophilic microorganisms can give new insight into plastic biodegradation in harsh conditions, such as high temperatures. Through meta-genomic approaches, a novel thermophilic PET hydrolase, has been recently identified from geothermal samples. This novel enzyme, denominated PP PETase (PP), was produced in recombinant form and purified to carry on it physico-chemical analyses and assess the thermal stability and structural features of PP to provide deeper insights into its functional and structural properties and identify its potential applications.

[1] V. Tournier, S. Duquesne, F. Guillaumot, H. Cramail, D. Taton, A. Marty, and I. André, *Chem. Rev.* 123 (2023) 5612–5701.

[2] M. Koller, K. Matsumoto, Z. Wang, F. Li, A.A. Shah, *Editorial: Biodegradation of Plastics. Front. Bioeng. Biotechnol.* 11 (2023) 1150078

[3] S. Yoshida, K. Hiraga, I. Taniguchi, K. Oda, and *Ideonella Sakaiensis*, *Methods Enzymol.* 648 (2021) 187–205.

## Gellan gum/pectin films loaded with saffron by-products: a promising strategy for wound healing applications

Francesco Busto,<sup>a,b</sup> Caterina Licini,<sup>c</sup> Alessia Luccarini,<sup>d</sup> Elisabetta Damiani,<sup>d</sup> Tiziana Bacchetti,<sup>d</sup> Monica Mattioli-Belmonte,<sup>b,c</sup> Stefania Cometa,<sup>e</sup> and Elvira De Giglio<sup>a,b</sup>

<sup>a</sup> *Dipartimento di Chimica, Università degli studi di Bari "Aldo Moro", Via Edoardo Orabona, 4, 70126 Bari, Italy*

<sup>b</sup> *INSTM, Consorzio Nazionale Scienza e Tecnologia dei Materiali, Via G. Giusti 9, 50121 Florence, Italy*

<sup>c</sup> *Dipartimento di Scienze Cliniche e Molecolari, Università Politecnica delle Marche, Via Tronto 10/a, 60126 Ancona, Italy*

<sup>d</sup> *Dipartimento di Scienze della Vita e dell'Ambiente, Università Politecnica delle Marche, Via Brecce Bianche, 60131 Ancona, Italy*

<sup>e</sup> *Jaber Innovation s.r.l., Via Calcutta 8, 00144 Rome, Italy*

E-mail: [francesco.busto@uniba.it](mailto:francesco.busto@uniba.it)

Tepals of *Crocus sativus*, usually wasted in saffron production, are an unexplored source of bioactive compounds [1]. In this study, three different hydrogel films based on low-acyl gellan gum (GG) blended with pectin (Pec), cross-linked with tartaric acid and CaCl<sub>2</sub>, were loaded with a *C. sativus*' tepals extract (CSE) (Figure 1). The excellent CSE antioxidant properties provide an effective strategy to combat significant cellular oxidative stress typical of skin wounds, allowing healing of damaged cellular tissues [2, 3]. The films were subjected to chemical-physical characterization by FTIR-ATR, XPS, TGA and DSC. Evaluation of water-uptake and water holding capacity were monitored in simulated wound fluid and PBS. The CSE and CSE-loaded films' total polyphenols content, and the antioxidant activity by ABTS and DPPH assays, were also evaluated. The study of the release kinetics of polyphenols from CSE-loaded films was carried out by the Franz diffusion cell. In vitro biological performances of the proposed materials were tested on human normal dermal fibroblasts (NhDFs) and on an immortalized keratinocyte cell line (HaCaT), demonstrating good cytocompatibility and capability to modulate wound healing.



**Figure 1:** From left to right: 1.6:0.4, 1:1, 0.4:1.6 Pec:GG/CSE films

[1] L. Bellachioma, G. Rocchetti, C. Morresi, E. Martinelli, L. Lucini, G. Ferretti, E. Damiani, and T. Bacchetti. *Int J Food Sci Technol* 57 (2022) 3838-3849.

[2] F. Busto, C. Licini, A. Luccarini, E. Damiani, M. Mattioli-Belmonte, S. Cometa, and E. De Giglio. *Molecules* 28 (2023) 11: 4352.

[3] M. Rezvanian, Ng. Shioh-Fern, T. Alavi, W. Ahmad. *Int. J. of Biological Macromolecules* 171 (2021) 308-319

## Not just $\beta$ -oxidation: NMR spectroscopy sheds light on a novel enzymatic reaction in mitochondrial long-chain fatty acid metabolism

Simone Fabbian,<sup>a,b</sup> Gabriele Giachin,<sup>b</sup> and Elisabetta Schievano<sup>b</sup>

<sup>a</sup> Department of Pharmaceutical and Pharmacological Sciences, University of Padua, Via Marzolo 5, 35131, Italy

<sup>b</sup> Department of Chemical Sciences, University of Padua, Via Marzolo 1, 35131, Italy

E-mail: [simone.fabbian@unipd.it](mailto:simone.fabbian@unipd.it)

Mitochondrial fatty acid  $\beta$ -oxidation (FAO) is a crucial pathway for cellular energy production [1], and deficiencies in FAO enzymes are responsible for a wide range of pathological conditions [2]. The lack of effective therapies underlies the urgency of deepening our understanding of FAO molecular mechanisms. To date, the atomic-level characterization of each FAO reaction has not been performed. NMR is a powerful technique for this purpose [1], capable of accurately reconstructing the structure of FAO products in a native environment essential for enzymatic catalysis. NMR analysis can also be extended to mitochondria for real-time detection under both physiological and pathological conditions, with significant implications for the diagnosis and treatment of FAO disorders.

Here, we present the molecular characterization of the first reaction in fatty acid  $\beta$ -oxidation through the integrative use of NMR and MS. In detail, we studied the  $\alpha$ - $\beta$ -dehydrogenation of palmitoyl-CoA catalysed by two homologous acyl-CoA dehydrogenases: very-long chain acyl-CoA dehydrogenase (VLCAD) and acyl-CoA dehydrogenase family member 9 (ACAD9), whose deficiencies are associated with severe FAO disorders [2]-[3]. Through  $^1\text{H}$ - $^{13}\text{C}$  HSQC analysis followed by  $^1\text{H}$ - $^1\text{H}$  TOCSY assignment, we identified not only the expected E-2-hexadecenoyl-CoA but also a significant percentage of a second product resulting from different dehydrogenation of palmitoyl-CoA. This novel reaction could be involved in previously unknown mechanisms regulating FAO or may serve as a hallmark of acyl-CoA dehydrogenase defects, potentially exacerbated by pathogenic mutations linked to FAO disorders.

Our findings enhance the understanding of fatty acid  $\beta$ -oxidation and pave the way for atomic-level investigations of FAO disorders using NMR analysis. Extending our study to enzymes with pathogenic mutations, will provide new insights into FAO disorders, for the development of targeted therapies.

[1] S. Demine, N. Reddy, P. Renard, M. Raes, and T. Arnould *Metabolites*. 4 (2014) 831-878

[2] A. Nsiah-Sefaa, and M. McKenzie *Bioscience Rep.* 36 (2016) 1-19

[3] M. Schiff, B. et al. *Human Mol. Gen.* 24 (2015) 3238-3247

## Synthetic glycolipids and their formulation in biocompatible nanovesicles

Andrea Sodini,<sup>a</sup> Filippo Susini,<sup>a</sup> Silvia Fallarini,<sup>b</sup> Francesca Natali,<sup>c</sup> Francesca Maestrelli<sup>a</sup> and Cristina Nativi<sup>a</sup>

<sup>a</sup> Department of Chemistry, University of Florence, Via della Lastruccia 3-13, 50019-Sesto Fiorentino, Italy.

<sup>b</sup> Department of Science and Technological Innovation, University of Piemonte Orientale, 15121 Alessandria, Italy.

<sup>c</sup> CNR-IOM and INSIDE@ILL, c/o OGG, 71 avenue des Martyrs, 38042 Grenoble Cedex 9, France.

E-mail: [andrea.sodini@unifi.it](mailto:andrea.sodini@unifi.it)

Cancer immunotherapy is nowadays a consolidated strategy and Tumor-Associated Carbohydrate Antigens (TACAs) are used to develop therapeutic cancer vaccines (CVs). In designing a potential TACA-based CV it must be considered that saccharidic antigens suffer from a reduced metabolic stability *in vivo* and a poor T cells-dependent immunogenicity, which compromise a strong immune response, crucial for a promising CV. To address these challenges, synthetic organic chemists are designing TACA analogues that mimic the native antigens but have improved stability and immunogenicity [1]. Biocompatible lipid nanovesicles, such as niosomes, can be used to present immunogenic antigens.

Niosomes are synthetic nanodimensional structures consisting of non-ionic surfactants, assembled autonomously in an aqueous environment in the form of a lipid bilayer which can be used to present immunogenic antigens.

A well-established method to improve the efficacy of an anti-cancer vaccine is using immunogenic adjuvants, which can be co-injected or covalently linked to the antigen.  $\alpha$ -GalCer is a synthetic glycolipid derivative of natural compounds isolated from marine sponges and it exhibits an intrinsic immunomodulatory and antitumor activity *in vivo* animal models [2].

Herein we have reported an innovative total synthesis of an  $\alpha$ -GalCer analogue, whose synthetic route proved to be an effective and versatile strategy for the synthesis of glycolipid derivatives with a ceramide structure. We have synthesized a mimetic of the tumoral Tn and STn antigen and functionalized them with an aliphatic chain for the formulation in niosomes. The resulting glycolipid were presented in a multivalent way by formulating it in biocompatible nanovesicles that were properly produced and characterized in terms of morphology, shape, dimension, and surface charge.

[1] R. M. Wilson and S. J. Danishefsky *J. Am. Chem. Soc.* 135, (2013) 14462-14472.

[2] M. Morita, K. Motoki, K. Akimoto, T. Sakai, E. Sawa, K. Yamaji, Y. Koezula, E. Kobayashi, H. Fukushima, *J Med Chem.* 9, (1995) 2176-2187.

## Valorization of bioactive stilbenoids derived from agri-food residues through chemo-enzymatic approaches

Giulia Brioschi, Francesca Annunziata, Cecilia Pinna, Martina Letizia Contente, Andrea Pinto, Sabrina Dallavalle, and Gigliola Borgonovo

Department of Food, Environmental and Nutritional Science, University of Milan, via Celoria 2, 20133-Milan, Italy

E-mail: [giulia.brioschi2@unmi.it](mailto:giulia.brioschi2@unmi.it)

Agri-food industries generate significant amounts of food loss and waste [1], especially from fruit and vegetable processing. These include peels, seeds, leaves, and stems rich in high-value natural compounds that are interesting for different industrial sectors (i.e., nutraceutical, cosmetic and pharmaceutical).

Resveratrol, a stilbene found in grapes, is a natural phytoalexin [2]. It has been intensively studied for its variety of biological activities, along with its metabolites. However, the scarce quantity and difficult isolation of pure compounds present in the natural matrices have hampered the biological investigation.

To expand the knowledge on the structure-activity relationships of this class of natural compounds, we developed synthetic procedures for the obtainment of natural monomeric stilbenoids, their metabolites and synthetic analogues. In particular, deoxy- and dihydro-derivatives of resveratrol, pterostilbene, deoxyrhapontigenin and 3-hydroxy-4,5-dimethoxystilbene were prepared. The synthetic strategies include Heck reactions, enzymatic deprotection steps mediated by imm-CalB, methylation reactions, and continuous Pd/C catalyzed hydrogenation using an H-Cube reactor.

The obtained compounds are currently under biological evaluation as antifungals. The test aims to evaluate the impact of exploited chemical modifications on the inhibition of *P. orizae* mycelium growth, spore germination and appressorium formation.

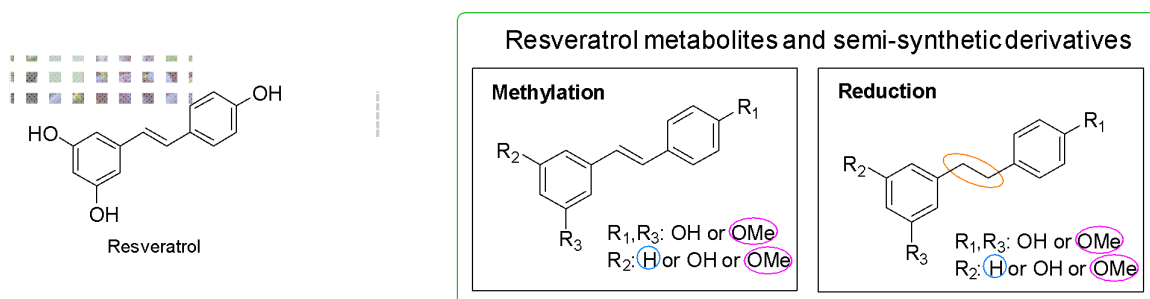

**Figure 1:** From agri-food residues to high value-added bioactive molecules.

[1] <https://www.fao.org/policy-support/policy-themes/food-loss-food-waste/en/>

[2] L. M. Mattio et al., *Scientific Reports* (2019), 9, 19525.

## Investigating the Italian flora to discover new weapons against glioblastoma multiforme

Alice Fossati,<sup>a,b</sup> Valeria Cavalloro,<sup>a,b</sup> Daniela Rossi,<sup>c</sup> Simona Collina,<sup>c</sup> Elisabetta Donzelli,<sup>d</sup> Mariarosaria Miloso,<sup>d</sup> Emanuela Martino<sup>a,b</sup>

<sup>a</sup> Department of Earth and Environmental Sciences, University of Pavia. Via Ferrata 1, 27100 Pavia, Italy.

<sup>b</sup> National Biodiversity Future Center. Piazza Marina 61, 90133 Palermo, Italy.

<sup>c</sup> Department of Drug Science, University of Pavia, Via Taramelli 12, 27100 Pavia, Italy.

<sup>d</sup> School of Medicine and Surgery, University of Milano Bicocca. Via Cadore 48, 20900 Monza, Italy.

E-mail: [alice.fossati01@universitadipavia.it](mailto:alice.fossati01@universitadipavia.it)

Glioblastoma multiforme (GBM) represents a highly aggressive primary brain tumor, constituting 48.6% of all primary malignant brain cancers [1]. The current standard treatment includes surgical resection, radiotherapy, and chemotherapy. GBM is still acknowledged as incurable, with a survival rate of less than 6 to 15 months, primarily due to pronounced treatment resistance and a propensity for aggressive relapse [2]. Natural compounds have been crucial in treating human disease. Accordingly, they may be the starting point for discovering bioactive compounds useful for treating tumors recalcitrant to traditional chemotherapy and radiotherapy [3].

Our current research aims to identify natural products with potential antiproliferative properties within the Italian Flora. Thanks to the collaboration with the National Biodiversity Future Center (NBFC, <https://www.nbfc.it/>), about 700 species of the Italian flora have been methodically selected and collected using a taxonomic approach. Among these species, eight were chosen for their good distribution and poor characterization from an antiproliferative standpoint. Their extracts were obtained using innovative extraction techniques and then subjected to a newly developed chlorophyll removal method, to avoid false positives due to the presence of chlorophyll. To evaluate the antiproliferative activity of the extracts, MTT assay was performed on the h-glioblastoma multiforme (U87-MG) cell line. As a result, four extracts exhibit a relevant effect. A bio-guided fractionation is ongoing with the ultimate goal to identify the main metabolite/metabolites responsible for the activity.

The project is funded under the National Recovery and Resilience Plan (NRRP), Mission 4 Component 2 Investment 1.4 – Call for tender No. 3138 of 16 December 2021, rettificata by Decree n.3175 of 18 December 2021 of Italian Ministry of University and Research funded by the European Union – NextGenerationEU. Project code CN\_00000033, Concession Decree No. 1034 of 17 June 2022 adopted by the Italian Ministry of University and Research, CUP F13C22000720007, Project title “National Biodiversity Future Center – NBFC”.

[1] S. Grochans, A. M. Cybulska, D. Simińska, J. Korbecki, K. Kojder, D. Chlubek and I. Baranowska-Bosiacka. *Cancers* 14 (2022) 2412.

[2] E. Obrador, P. Moreno-Murciano, M. Oriol-Caballo, R. López-Blanch, B. Pineda, J. L. Gutiérrez-Arroyo, A. Loras, L. G. Gonzalez-Bonet, C. Martinez-Cadenas, J. M. Estrela and M. Á. Marqués-Torrejón. *Int. J. Mol. Sci.* 25 (2024) 2529

[3] A. Naeem, P. Hu, M. Yang, J. Zhang, Y. Liu, W. Zhu and Q. Zheng. *Molecules* 27 (2022) 8367.

---

## FL043

### **Net analyte signal used to quantify the concentration of three active principles contained in Neonisidina®**

Nicholas Kassouf, Alessandro Zappi, and Dora Melucci

*Department of chemistry G.Ciamician, Alma Mater Studiorum University of Bologna, Via Gobetti 83, 40131 Bologna, Italy*

*E-mail: Nicholas.kassouf2@unibo.it*

Quality control in pharmaceutical manufacturing necessitates rigorous testing and approval adhering to Current Good Manufacturing Practices before commercialization. The production of solid drugs presents significant industrial challenges regarding uniformity, homogeneity, and consistency. Traditional quality guidelines rely on classical analytical methods such as liquid chromatography coupled with mass spectrometry (HPLC-MS). However, the emergence of Process Analytical Technology (PAT) introduced non-destructive, rapid, and cost-effective methods like UV-Visible Diffuse Reflectance Spectroscopy (UV-Vis DRS). This study aimed to develop a chemometric method for quantifying Active Pharmaceutical Ingredients (APIs) in Neonisidina ®, which is a solid mixture drug, using spectrophotometric data. The NAS (Net Analyte Signal) concept, combined with the standard addition method, facilitated the creation of a NAS-SAM model, overcoming challenges in solid-phase analysis by employing geometric dilutions for appropriate standards. Various preprocessing methods were evaluated, including first derivative, Standard Normal Variate (SNV), Multiplicative Scatter Correction (MSC). Net Analyte Signal (NAS) [1] regressions were employed for chemometric modeling. Results demonstrated successful quantification of APIs in ideal laboratory samples and real pharmaceutical tablets. NAS-based chemometric models showcased high precision and reliability, validated by comparisons with HPLC-DAD results. The study revealed that solid-phase spectrophotometric analyses yielded comparable results to HPLC-DAD, signifying its potential as a valid alternative for online analyses. Solid analysis offers non-destructive, cost-effective, and environmentally friendly benefits, enabling its integration into pharmaceutical production to improve quality control.

[1] D. Melucci, A. Zappi, F. Poggioli, P. Morozzi, F. Giglio, and L. Tositti, *Molecules* 24 (2019) 3927

---

## FL044

### Automated synthesis of libraries of iminosugar derivatives for plant protection

Sara Pavone,<sup>a</sup> Stefano Rendine,<sup>b</sup> Olivier Loiseleur,<sup>b</sup> Francesca Clemente,<sup>a</sup> Camilla Matassini,<sup>a</sup> and Francesca Cardona<sup>a</sup>

<sup>a</sup> Department of Chemistry “Ugo Schiff” (DICUS), Università degli Studi di Firenze, Via della Lastruccia 13, 50019, Sesto Fiorentino (FI), Italy

<sup>b</sup> Syngenta Crop Protection AG, Crop Protection Research, Schaffhauserstrasse, CH-4332 Stein, Switzerland, Switzerland

E-mail: [sara.pavone@unifi.it](mailto:sara.pavone@unifi.it)

Since few years the Italian kiwifruit crops are devastated by a bacterial canker disease caused by *Pseudomonas syringae* pv. *actinidiae* with relevant economic and environmental consequences [1]. Consequently, the development of new bactericides for this pathogen became an urgent challenge.

In collaboration with Syngenta AG, we are looking for natural compounds which are non-toxic for humans and plants but are able to inhibit of the bacterial growth of the pathogen. In particular, we envisaged that valuable candidates could be found among natural iminosugars, an interesting class of glycomimetics, and their synthetic derivatives.

Iminosugars are synthesized starting from commercial carbohydrates, with the introduction of the nitrogen atom achieved following the methodologies developed at the Università degli Studi di Firenze [2]. Then, in Syngenta AG, the libraries are designed considering factors such as molecular weight or chemical characteristics (for example logP) and synthesized using an automation laboratory system which renders the process more sustainable. In fact, the automated system permits to be more precise and to waste less materials and time.

The first libraries derived from an amide coupling between the endocyclic nitrogen of iminosugars and different acids, which produces compounds losing the basic feature of iminosugars. These new derivatives were tested towards different bacterial strains (*P. syringae* and *X. Oryzae*).

In the next libraries, the nitrogen atom of iminosugars maintains its basic feature and it is linked to different scaffolds present in the Syngenta stock by a bifunctional linker.

We thank #NEXTGENERATIONEU (NGEU) and the Ministry of University and Research (MUR), National Recovery and Resilience Plan (NRRP), DM 352/2022, for a PhD fellowship.

[1] L. Gardan, C. Bollet, M. Abu Ghorrah, F. Grimont, and P.A.D. Grimont, *Int. J. Syst. Bacteriol.* Ed 42 (1992) 606-612

[2] (a) C. Matassini, S. Mirabella, A. Goti, and F. Cardona, *Eur. J. Org. Chem.* (2012) 3920–3924 (b) F. Cardona, E. Faggi, F. Liguori, M. Cacciarini, and A. Goti, *Tetrahedron Letters* Ed. 44 (2003) 2315–2318 (c) P. Merino, I. Delso, T. Tejero, F. Cardona, M. Marradi, E. Faggi, C. Parmeggiani, and A. Goti, *Eur. J. Org. Chem.* Ed. 2008 (2008) 2929-2947

---

## FL045

### **Extraction of pharmacologically active substances from typical Italian plant species such as “Mugnoli di Pettorano sul Gizio” using analytical techniques and chemometric approaches**

Claudia Scappaticci, Alessandra Biancolillo, Martina Foschi, and Angelo Antonio D'Archivio

*Dipartimento di Scienze Fisiche e Chimiche, Università degli Studi dell'Aquila, Via Vetoio, 67100-L'Aquila, Italia*

*E-mail: [claudia.scappaticci@graduate.univaq.it](mailto:claudia.scappaticci@graduate.univaq.it)*

This study aims to analyze pharmacologically active substances in plant species, with a particular focus on the “Mugnoli di Pettorano sul Gizio”, by applying analytical methods for extract analysis and chemometric approaches for data processing. The Mugnoli are native species cultivated in Abruzzo (central Italy) and are of significant scientific interest due to the presence of pharmacologically active substances. These winter vegetables, grown in Pettorano sul Gizio (Abruzzo, Italy), withstand low temperatures and harsh winter climates. It is believed they were imported from Puglia (southern Italy) in the early 1900s by transhumant shepherds [1]. Being resistant to pests, they are a completely natural product grown without the use of pesticides and chemical fertilizers. Additionally, the seeds are not commercially available as they are passed down from one cultivation to another [2].

To study the composition of pharmacologically active substances, particularly antioxidants, a Design of Experiments (DoE) was planned to simultaneously investigate the effect of various factors at different levels. Commercial turnip greens were analyzed to identify the optimal conditions for maximum extraction of these substances and subsequently compare them with those found in the Mugnoli of interest. The plant species were analyzed using HPLC-DAD and UV-Vis spectroscopy, and the antioxidant power was assessed using the 2,2-diphenyl-1-picrylhydrazyl (DPPH) assay. The obtained data were then analyzed using chemometric approaches.

[1] L. Di Martino, A. Biancolillo, C. Scappaticci, M. Foschi, and A.A.D'Archivio, *Appl. Sci.* 14 (2024) 1277

[2] A. Biancolillo, R. Ferretti, C. Scappaticci, M. Foschi, A.A. D'Archivio, M. Di Santo, and L. Di Martino, *Appl. Sci.* 13 (2023) 6591

## Preparation, phytochemical characterization, and biological evaluation of extracts from pruning wood of *Prunus persica*

Elisabetta Tumminelli,<sup>a</sup> Valeria Cavalloro,<sup>b</sup> Emanuela Martino,<sup>b</sup> Simona Collina,<sup>a</sup> and Daniela Rossi<sup>a</sup>

<sup>a</sup> Department of Drug Sciences, University of Pavia, Viale Taramelli 12, 27100-Pavia, Italy

<sup>b</sup> Department of Earth and Environmental Sciences, University of Pavia Via S. Epifanio, 14, 27100-Pavia, Italy

E-mail: [elisabetta.tumminelli01@universitadipavia.it](mailto:elisabetta.tumminelli01@universitadipavia.it)

*Prunus persica* is a plant belonging to the Rosaceae family that is gaining increasing attention in the cosmetic sector for its beneficial properties. Particularly, its fruits, rich in vitamins, antioxidants and essential nutrients, are widely used for the preparation of extracts that are renowned for their moisturizing, nourishing, antioxidant, and anti-inflammatory capabilities, and thus ideal for a wide range of cosmetic applications [1]. Concerning pruning branches, to date, there are only few cosmetic formulations that involved extracts prepared using this biomass [2]. Considering that the pruning process generates 2 to 5 tons of wood waste annually, projected to increase by 70% over the next 40 years, it is clear that a re-use of this waste represents a huge challenge in a recycling perspective.

In this context, the present work was aimed at recycling and valorising *Prunus persica* pruning wood by preparing extracts using eco-sustainable solvents and evaluating their biological potential (i.e. antioxidant and antityrosinase activities). To this aim, different extraction procedures were experimented (i.e. maceration, microwave-assisted solvent extraction), a consolidated in-house method for removing interferences, was applied to all the extracts prepared to remove interferences (i.e. chlorophylls or tannins). The fingerprint of the extracts was finally drawn by means of HPLC-UV and HPLC-MS analysis, using a chromatographic methodology developed and optimized to purpose.

As the last step of the work, a bio-guided fractionation of the most interesting extract was performed. Results will be presented and discussed in due course.

This contribution is part of the project NODES which has received funding from the MUR – M4C2 1.5 of PNRR funded by the European Union – Next Generation EU (Grant agreement no. ECS00000036).

- [1]. N. Kumari, Radha, M.Kumar, S.Puri, B. Zhang, N.Rais, A. Pundir, D. Chandran, P. Raman, Sa.Dhumal, A. Dey, M. Senapathy, S. Kumar, B. R. Pokharel, V. Deshmukh, R. D. Damale, A. Thiagarajan, V. Balamurgan, G. Sathish, Surinder Singh, J. M. Lorenzo Food Biosci. (2023), 54, 102914.  
[2] M. J. A-González, J. Gabaston, V. O.-S. and E. C.-Villar, Biomolecules (2022), 12 (2), 238.

## Chemoselective $S_N2'$ homologation of allylic platforms with zinc carbenoids

Alberto Nardi and Vittorio Pace

Department of Chemistry, University of Turin, Via Pietro Giuria 7, 10125 Turin, Italy  
alberto.nardi@unito.it

Homologation chemistry has been subject of considerable attention in the last decade, leading to a lot of studies and publications investigation the possible combination of homologating agent and substrates [1]. Most of the known procedures foresee the employment of a nucleophilic species as the medium of the chain enlargement; among the several nucleophiles, lithium and magnesium carbenoids have been largely exploited for the exploration of this kind of chemistry [2]. A exception relies in zinc carbenoids, mostly known for their electrophilic behavior which made possible the Simmons-Smith cyclopropanation reaction of alkenes by iodomethylzinc iodide and ethyl(iodomethyl)zinc [3]. Still, zinc carbenoid chemistry is not as explored as other metals one. Herein we present the homologation of allylic halides (X: Br, Cl) to homoallylic iodides derived from a iodomethylene unit  $S_N2'$  type transfer mediated by iodomethylzinc iodide. More than 30 examples were synthesized achieving remarkable scope and chemoselectivity thanks to the neutral nature of zinc carbenoids toward electrophilic site sas amides, esters, ketones and aldehydes.

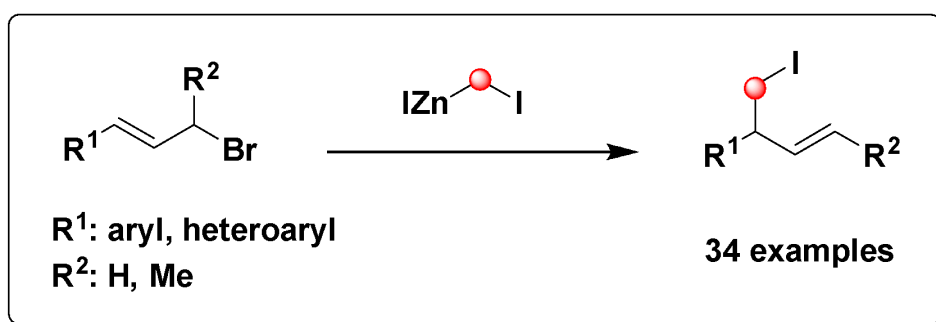

**Figure 1:** Zinc carbenoid homologation of allylic halides.

- [1] Pace, V. *Homologation Reactions: Reagents, Applications and Mechanisms*. Wiley-VCH: Weinheim, 2023.  
 [2] a) L. Ielo et al., *Synlett*, 2020, 32; b) V. Pace, L. Castoldi, W. Holzer, *Adv. Synth. Cat.* 2014, 1761–1766; c) V. Pace et al. *Angew. Chem.*, 2017, 129.41, 12851–12856. i) V. Pace; *Australian Journal of Chemistry*, 2014, 67, 311–313  
 [3] a) H. E. Simmons; R. D. Smith; *J. Am. Chem. Soc.*; 1958, 80, 5323. b) H. E. Simmons; R. D. Smith; *J. Am. Chem. Soc.*; 1959, 81, 4256. c) J. Furukawa; N. Kawabata, *Adv. Organomet. Chem.*; 1974, 12, 83.

## Novel 6,7-dimethoxy-4-piperazinylquinoline derivatives as promising antibacterial agents against *Staphylococcus aureus*

Federica Alamia, Gabriele La Monica, Alessia Bono, Antonino Lauria, Rosa Alduina, Anna Maria Gallo, and Annamaria Martorana

Dipartimento "STEBICEF" – Università degli Studi di Palermo, Viale delle Scienze – 90128-Palermo, Italy.

E-mail: [federica.alamia01@unipa.it](mailto:federica.alamia01@unipa.it)

In the field of medicinal chemistry, significant research efforts are dedicated to developing new antibiotics targeting clinically validated enzymes such as DNA gyrase and topoisomerase IV, which are crucial for bacterial DNA replication. Among the frontline classes of agents against broad-spectrum bacterial infections, quinolines and their analogues are particularly effective in inhibiting both targets [1]. However, the recent emergence of resistance, due to mutations that impair drug accumulation in bacterial cells and target recognition, has driven the development of new approaches for discovering innovative inhibitors. Drawing on our experience in the synthesis of quinoline-based compounds, we have focused on the study of piperazinylquinoline derivatives with potential antibiotic activity [2].

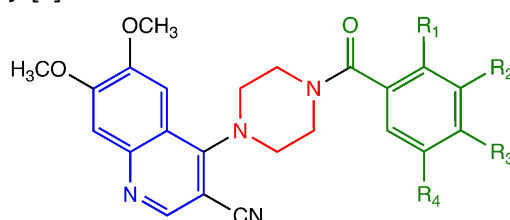

**1a-k**

**Figure 1.** General structure of 6,7-dimethoxy-4-piperazinylquinoline compounds **1a-k**.

Induced Fit Docking (IFD) studies were performed on the DNA gyrase of *S. aureus* (PDB code 6FM4), to assess protein-ligand interactions between our molecular dataset and the target binding sites. The 6,7-dimethoxy-4-piperazinylquinoline compounds **1a-k** (Figure 1) showed remarkable binding affinity to the DNA gyrase comparable to that of the reference ligand. The selected molecules were synthesized using appropriate synthetic strategies and characterized spectroscopically. Preliminary antibacterial tests showed promising activity of piperazinyl quinolines against *S. aureus*, known for its resistance to many conventional antibiotic therapies. Further *in vitro* studies are currently underway to elucidate the mechanism of action and validate the efficacy and therapeutic potential of these compounds.

[1] K. B. Patel, P Kumari, *Journal of Molecular Structure* (2022) 133634

[2] G. La Monica, G. Pizzolanti, C. Baiamonte, A. Bono, F. Alamia, F. Mingoia, A. Lauria, A. Martorana, *ACS Omega* (2023) 6;8(50):48582.

## Multiple drug-delivery strategies to enhance the pharmacological and toxicological properties of mefenamic acid

Chiara Battisegola,<sup>a</sup> Claudia Cristiano,<sup>a</sup> Robert J. Cavanagh,<sup>b</sup> Philippa L. Jacob,<sup>c</sup> Marica Erminia Schiano,<sup>a</sup> Roberto Russo,<sup>a</sup> Vincenzo Taresco,<sup>c</sup> Federica Sodano<sup>a</sup> and Maria Grazia Rimoli<sup>a</sup>

<sup>a</sup> Dipartimento di Farmacia, Università degli Studi di Napoli Federico II, Via Domenico Montesano 49, 80131-Napoli, Italia

<sup>b</sup> School of Medicine, BioDiscovery Institute-3, University Park, Nottingham NG7 2RD, United Kingdom

<sup>c</sup> School of Chemistry, University of Nottingham, Nottingham NG7 2RD, United Kingdom

E-mail: [chiara.battisegola@unina.it](mailto:chiara.battisegola@unina.it)

To improve the biological and toxicological properties of Mefenamic acid (MA), the galactosylated prodrug of MA named MefeGAL was included in polymeric solid dispersions (PSs) composed of poly(glycerol adipate) (PGA) and Pluronic® F68 (MefeGAL-PS). MefeGAL-PS was compared with polymeric solid formulations of MA (MA-PS) or a mixture of equal ratio of MefeGAL/MA (Mix-PS). The *in-vitro* and *in-vivo* pharmacological and toxicological profiles of PSs have been investigated. In detail, we evaluated the anti-inflammatory (carrageenan-induced paw edema test), analgesic (acetic acid induced writhing test) and ulcerogenic activity in mice after oral treatment.

Additionally, the antiproliferative activity of PSs was assessed on *in vitro* models of colorectal and non-small cell lung cancer. When the PSs were resuspended in water, MefeGAL's, MA's and their mixture's apparent solubilities improved due to the interaction with the polymeric formulation. By comparing the *in-vivo* biological performance of MefeGAL-PS with that of MA, MefeGAL and MA-PS, it was seen that MefeGAL-PS exhibited the same sustained and delayed analgesic and anti-inflammatory profile as MefeGAL but did not cause gastrointestinal irritation. The pharmacological effect of Mix-PS was present from the first hours after administration, lasting about 44 hours with only slight gastric mucosa irritation. *In-vitro* evaluation indicated that Mix-PS had statistically significant higher cytotoxicity than MA-PS and MefeGAL-PS. These preliminary data, sketched in Figure 1, are promising evidence that the galactosylated prodrug approach in tandem with a polymer-drug solid dispersion formulation strategy could represent a new drug delivery route to improve the solubility and biological activity of NSAIDs.

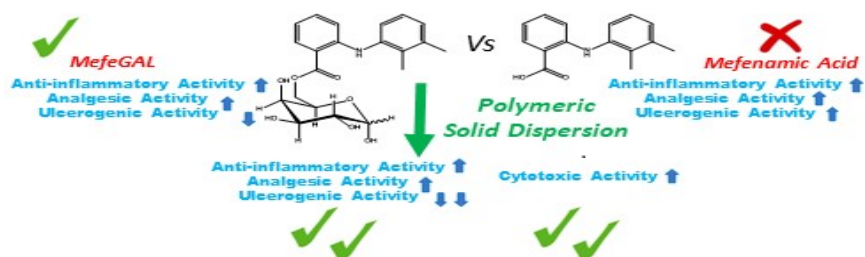

**Figure 1:** Schematic illustration of the results of the present study.

## Beyond conventional therapies: “Trojan horse” conjugates for advanced drug delivery

Marianna Fava, Valeria Tudino, Ludovica Marotta, Stefania Butini, Giuseppe Campiani, and Sandra Gemma.

Department of Biotechnology, Chemistry and Pharmacy, University of Siena, Via Aldo Moro 2, Siena 53100, Italy.

E-mail: [marianna.fava@student.unisi.it](mailto:marianna.fava@student.unisi.it)

Iron is an essential element for microbial growth and survival. In iron depleted conditions, both Gram-positive and Gram-negative bacteria produce and secrete siderophores, low molecular weight iron(III) chelating metabolites. The Ferric-siderophore complex is recognized by specific membrane receptors and actively transported into the cytoplasm through an energy-dependent system [1]. The growing bacterial resistance, especially in gram-negative strains, against the currently available panel of antimicrobial agents requires alternative ways to counteract it. The “Trojan horse” strategy is a promising approach to deliver drugs into cells bypassing membrane-associated drug resistance using iron transport machinery (Figure 1). In the light of these considerations, this work was focused on the development of new siderophore-antibiotic conjugates, constituted by three parts; an iron chelating moiety, a linker and a drug [1],[2]. Several known antimicrobial agents were explored, as fosmidomycin and its N-acetyl derivative, FR-900098, natural competitive inhibitors of 1-deoxy-D-xylulose 5-phosphate reductoisomerase (Dxr), a key enzyme involved in the non-mevalonate isoprenoid biosynthesis pathway [3]. Due to their unfavorable pharmacokinetic properties, these agents are ideal candidate for conjugation. The proposed linkers may allow to control the release of the drug into the target bacterial cell thanks to catabolic enzymes or specific environmental conditions, while the employed chelating moieties were chosen on the base of their high affinity for siderophore receptors [1].

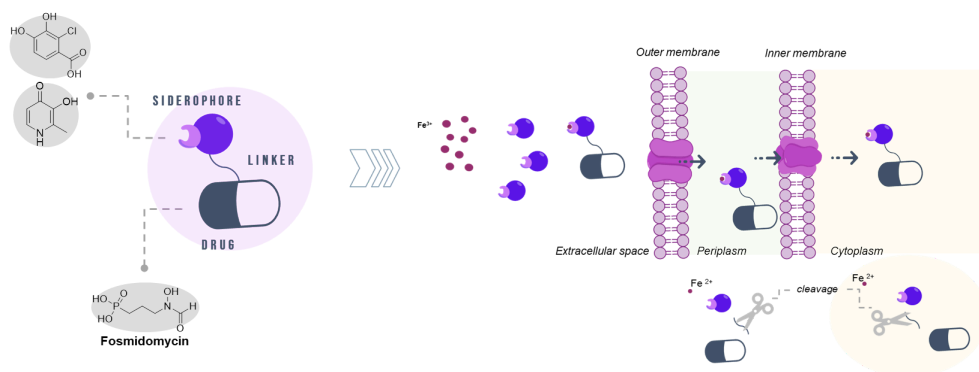

**Figure 1:** A schematic representation of “Trojan horse” strategy.

[1] Negash ,K.H., Norris, J.K.S., Hodgkinson, J.T., *Molecules*. (2019) 24, 3314.

[2] Górska, A., Sloderbach, A., and Marszałł, M. P., *Trends Pharmacol Sci*. (2014) 35, 442-449.

[3] Palla, D.; Antoniou, A.I.; Baltas, M.; Menendez, C.; Grellier, P.; Mouray, E.; Athanassopoulos, C.M. *Molecules* (2020) 25, 4858.

## Machine learning model for predicting molecular activity using Molecular Descriptors and ElectroShape Descriptors

Alessia Bono,<sup>a,b</sup> Aras Asad,<sup>b,c</sup> Marco Albanese,<sup>b</sup> Richard Ian Cooper,<sup>b,d</sup> Antonino Lauria,<sup>a</sup>  
Gabriele La Monica,<sup>a</sup> Federica Alamia,<sup>a</sup> Annamaria Martorana,<sup>a</sup> and Paul William Finn<sup>b,c</sup>

<sup>a</sup> Dipartimento “STEBICEF” – Università degli Studi di Palermo, Viale delle  
Scienze – Ed. 17, 90128, Palermo, Italy.

<sup>b</sup> Oxford Drug Design, Oxford Centre for Innovation, New Road, Oxford, OX1 1BY, UK.

<sup>c</sup> School of Computing, University of Buckingham, Hunter Street, Buckingham, MK18 1EG, UK.

<sup>d</sup> Chemical Crystallography, Chemistry Research Laboratory, 12 Mansfield Road, Oxford, OX1 3TA UK.

E-mail: [alessia.bono01@unipa.it](mailto:alessia.bono01@unipa.it)

Machine Learning (ML) algorithms are revolutionizing pharmaceutical and biomedical research by analyzing large datasets to make predictions across various fields. A key challenge is learning useful molecular representations. Here, we present the development of an ML model designed to discriminate between active and inactive compounds towards biological targets. Our approach utilized Molecular Descriptors (MD), computed via MOLDESTO, and 4D ElectroShape Descriptors (4DES) to represent small molecules in the Maximum Unbiased Validation (MUV) dataset. MDs provide features capturing various physicochemical properties of small molecules. On the other hand, 4DES are advanced descriptors that incorporate three-dimensional spatial and electronic properties, offering a richer representation for capturing subtle molecular differences. The MUV dataset, including assay data for 17 targets, minimizes analogue bias and artificial enrichment. We developed a Support Vector Machine (SVM) model and applied 5-fold cross-validation to assess its performance using metrics such as Area Under the Curve (AUC) and the 1% Enrichment Factor (1%EF).

Initial results showed that models using MD alone achieved an AUC of  $0.759 \pm 0.099$ , while 4DES alone achieved  $0.635 \pm 0.113$ . Combining MD and 4DES slightly improved performance, reaching an AUC of  $0.763 \pm 0.099$ . Further refinement through SHapley Additive exPlanations (SHAP) for feature selection improved the AUC values to  $0.810 \pm 0.082$  for MD alone and  $0.811 \pm 0.084$  for the combined descriptors. These findings underscore the importance of feature selection in enhancing model performance.

Additionally, we performed a 3-fold cross-validation by splitting the MUV dataset into three groups based on target numerical codes and FASTA sequence similarity. This demonstrated the model's robustness to discriminate between actives and inactives across different test scenarios. Finally, we evaluated the model on the LIT-PCBA dataset, achieving promising performance. These findings highlight the effectiveness of our approach and its potential for advancing virtual screening in drug discovery.

## Fighting chronic inflammation by inhibiting the HMGB1 protein as a promising target for the development of innovative anti-inflammatory bioactive and RNA-based compound

Enrico Mario Alessandro Fassi,<sup>a</sup> Marco Manenti,<sup>b</sup> Marco Albani,<sup>a</sup> Francesca Palone,<sup>c</sup> Alessandra Silvani,<sup>b</sup> and Giovanni Grazioso<sup>a</sup>

<sup>a</sup> Department of Pharmaceutical Sciences, University of Milan, Via Mangiagalli 25, 20133, Milan, Italy.

<sup>b</sup> Department of Chemistry, University of Milan, via C. Golgi 19, 20133, Milan, Italy.

<sup>c</sup> Laboratory of Biomedical Technologies, Italian National Agency for New Technologies, Energy and Sustainable Economic Development (ENEA), Via Anguillarese 301, 00123, Rome, Italy.

E-mail: [enrico.fassi@unimi.it](mailto:enrico.fassi@unimi.it)

Chronic inflammation is an abnormal immune response where inflammation persists longer than usual or starts without infection or injury. Over time, it can harm healthy cells and cause autoimmune conditions and diseases like cancer. Current treatments, mainly nonsteroidal anti-inflammatory drugs (NSAIDs) and corticosteroids, only slightly reduce the symptoms and the progression of the disease but have numerous side effects and negatively impacting the quality of life of patients.

In this framework, the alarmin High-Mobility Group Box 1 (HMGB1) has been identified as one of the main mediators in chronic inflammation, playing a significant role in several pathological conditions including rheumatoid arthritis, systemic lupus erythematosus, inflammatory bowel diseases, and other autoimmune diseases [1]. Despite the importance of this target, no efficient inhibitors are currently available. In fact, only few compounds are reported in literature, however, their low affinity to HMGB1, together with their low selectivity for the biochemical pathways, make these compounds unsuitable to investigate the therapeutic effects of the HMGB1 inhibition, and even less to be potential anti-inflammatory drug candidates [2].

We developed a series of small molecules with high affinity for HMGB1, as shown in Microscale Thermophoresis (MST) experiments. These compounds demonstrated the highest affinity for HMGB1 reported in literature. Preliminary in vitro experiments on RAW 264.7 cells treated with lipopolysaccharides (LPS) showed that these molecules significantly reduced the mRNA expression of proinflammatory cytokines (il-6, tnf- $\alpha$ , il-1 $\beta$ ) and receptors (RAGE, TLR4). Additionally, the compounds significantly reduced HMGB1 expression and inhibited its extracellular release in inflamed RAW 264.7 cells.

Alongside this classical approach, we have also targeted the DNA binding domain of HMGB1 by designing new ligands featuring phosphorodiamidate morpholino oligomer (PMO) structures, which are short single-stranded DNA analogs, yielding promising results.

[1] M. Magna, and D.S. Pisetsky, *Mol Med.* (2014) 138–146

[2] L. Mollica, F. De Marchis, A. Spitaleri, C. Dallacosta, D. Pennacchini, M. Zamai, A. Agresti, L. Trisciuglio, G. Musco, and M.E. Bianchi, *Chem Biol.* (2007) 431–441.

## A machine learning-based approach to identify the selectivity profiles of sigma receptors ligands

Lisa Lombardo,<sup>a</sup> Verena Battisti,<sup>b</sup> Rosaria Gitto,<sup>a</sup> Thierry Langer,<sup>b</sup> Laura De Luca,<sup>a</sup>

<sup>a</sup> *Department of Chemical, Biological, Pharmaceutical, and Environmental Sciences, University of Messina, Viale Ferdinando Stagno d'Alcontres 31, 98166, Messina, Italy*

<sup>b</sup> *Department of Pharmaceutical Sciences, Division of Pharmaceutical Chemistry, University of Vienna, Josef-Holaubek-Platz 2, 2D 303 A-1090 Vienna, Austria*

E-mail: [lisa.lombardo@studenti.unime.it](mailto:lisa.lombardo@studenti.unime.it)

Sigma-1 Receptor (S1R) and Sigma-2 Receptor (S2R) are unique chaperone proteins differing in folding, tissue distribution, and pharmacological profiles. S1R is highly expressed in the central nervous system and often associated with neuroprotection and neurodegenerative diseases; whereas, S2R is highly expressed in cancer cells and plays a crucial role in cellular proliferation and apoptosis [1]. Despite distinct structures, their similar features in the binding site allow for overlapping ligand recognition profiles. Furthermore, the elusive nature of their endogenous ligands underscores the need to discern selective binding patterns to better understand their roles [2]. Therefore, the identification of selective ligands for S1R and S2R might be of central interest for development of new therapeutics in human diseases.

In this study, our efforts were focused to develop a comprehensive machine learning (ML) approach to predict the selectivity of compounds towards S1R and S2R. The workflow started with the curation of high confidence data extracted from three public sources (ChEMBL, BindingDB and PubChem BioAssay) to build training datasets. Then, the molecular descriptors and fingerprints were extracted to capture the chemical features of ligands. The datasets were employed to train multiple ML models, including Random Forest, Support Vector Machine, and Neural Networks, to classify and predict receptor selectivity. Hyperparameter tuning and model validation were rigorously performed to ensure robust and accurate predictions. This ML-driven method will provide a powerful tool for the rational design of selective sigma receptor modulators, potentially accelerating the discovery of novel potent and selective ligands for S1R/S2R.

This work was supported by Italian Ministry of Education, University and Research: (project PRIN 201744BN5). The authors thank the “Programma Operativo Nazionale Ricerca & Innovazione 2014–2020, Azione IV.5 “Dottorati e contratti di ricerca su tematiche dell’innovazione” XXXVII cycle, for financial support in form of a PhD scholarship “DOT1314952” granted to Lisa Lombardo.

[1] H. R.Schmidt, A.C. Kruse. *Trends in Pharmacological Sciences* (2019), 40(8), 636-654.

[2] J. Pergolizzi, G. Varrassi, M. Coleman, F. Breve, D.K. Christo, P.J. Christo, C. Moussa. *Cureus* (2023), 15(3):e35756.

## Overcoming cancer therapy resistance: the role of arginase inhibitors

Maria Cristina Molaro,<sup>a</sup> Mariacristina Failla,<sup>b</sup> Marica Erminia Schiano,<sup>a</sup> Marta Serafini,<sup>b</sup> Eleonora Gianquinto,<sup>b</sup> Chiara Battisegola,<sup>a</sup> Konstantin Chegaev,<sup>b</sup> Loretta Lazzarato,<sup>b</sup> Francesca Spyraakis<sup>b</sup> and Federica Sodano<sup>a</sup>

<sup>a</sup> Dipartimento di Farmacia, Università degli Studi di Napoli Federico II, Via Domenico Montesano 49, 80131-Napoli, Italia

<sup>b</sup> Dipartimento di Scienza e Tecnologia del Farmaco, Università degli Studi di Torino, Via Pietro Giuria 9, 10125- Torino, Italia

E-mail: [mariacristina.molaro@unina.it](mailto:mariacristina.molaro@unina.it)

The overexpression of two arginase (ARG) isoforms, ARG1 and ARG2, contributes to the onset of numerous disorders, including cancer [1]. To elucidate the specific roles of ARG1 and ARG2 without disrupting their physiological functions, it is crucial to develop effective ARG inhibitors that are selective for one isoform, exhibiting low toxicity, and have an adequate pharmacokinetic profile. Given the general lack of activity and selectivity among current inhibitors [2], the binding site structure and plasticity of ARG1 and ARG2 were investigated to evaluate the possibility of design inhibitors with novel binding patterns.

Furthermore, ARG regulates cellular nitric oxide (NO) production by competing with nitric oxide synthase (NOS) for the common substrate L-arginine. An imbalance between arginase and NOS can cause low NO production, resulting in the M1-M2 transition in macrophages, which contributes to tumor progression. Inhibition of ARGs would allow L-arginine to be available exclusively as a substrate for NOS enzymes, increasing NO production in tumour cells and macrophages and thus activating immunity towards immunologically active M1 macrophages. Therefore, as sketched in Figure 1, the design and synthesis of NO-releasing drugs, in addition to ARG inhibition, is another viable strategy to effectively eradicate tumours.

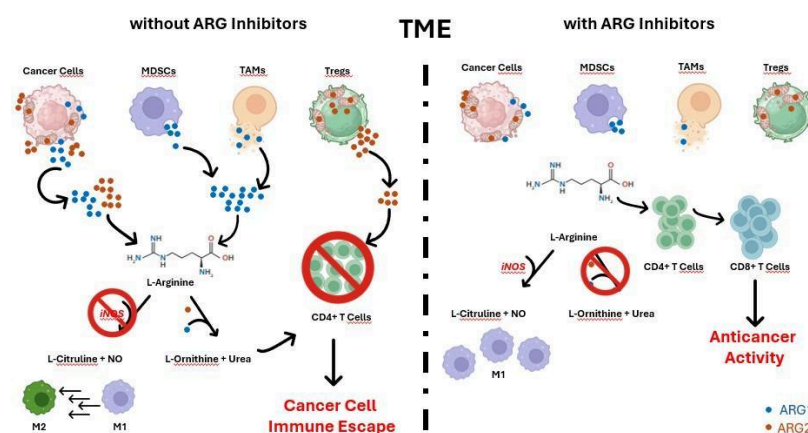

**Figure 1:** Comparison of tumor microenvironment with and without ARG inhibitors.

[1] J. Moretto, M. Pudlo, C. Demougeot, *Drug Discov Today* 26 (2021) 138-147.

[2] B. Borek, T. Gajda, A. Golebiowski, R. Blaszczyk, *Bioorg Med Chem* 28 (2020) 115658.

## **Functionalization of cellulose matrices towards the preparation of antibacterial composites**

Federica Meringolo,<sup>a</sup> Loredana Maiuolo,<sup>a</sup> Vincenzo Algieri,<sup>b</sup> Antonio Jiritano,<sup>a</sup> Antonio De Nino,<sup>a</sup> Giuseppe Arrabito,<sup>c</sup> Floriana Campanile,<sup>d</sup> and Paola Costanzo<sup>a</sup>

<sup>a</sup> *Department of Chemistry and Chemical Technologies, University of Calabria, Pietro Bucci street, 87036-Rende (CS), Italy*

<sup>b</sup> *IRCCS NEUROMED—Mediterranean Neurological Institute, Atinense street 18, IS, Pozzilli, 86077, Italy*

<sup>c</sup> *Department of Physics and Chemistry - Emilio Segré, University of Palermo, V.le delle Scienze Ed. 17, 90128-Palermo, Italy*

<sup>d</sup> *Department of Biomedical and Biotechnological Sciences (BIOMETEC) - University of Catania. Torre Biologica Via S. Sofia n. 97, 95123 Catania, Italy.*

*E-mail: [federica.meringolo@unical.it](mailto:federica.meringolo@unical.it)*

Cellulose is the most abundant natural material available on earth [1]. Cellulose is non-toxic, biodegradable, biocompatible, and a renewable organic material, making it a good alternative to petroleum-based materials. The properties of cellulose make it interesting for the development of nanotechnology. For this very reason, it is often combined with metal nanoparticles for various biomedical applications, for example to research new antimicrobial agents, a global challenge due to microbial resistance to antibiotics (AMR). In particular, our studies concern the development of different cellulosic materials, such as cellulose paper or powder, functionalized with amino groups on the surface, with the aim to act as carriers for ZnO nanowires (ZnO-NWs), for the development of non-drug antimicrobial strategies. The introduction of amino pendants was associated with antibacterial properties, miming the intrinsic bactericidal activity of chitosan, since cellulose does not have any antibacterial activity, which limited its application. Functionalization of cellulose via alkoxy silanes is one of the most efficient, environmentally friendly and safe ways to introduce a wide variety of functional groups [2]. Cellulosic papers were functionalized with 3-aminopropyltriethoxysilane (APTES). Different reaction conditions, and heating sources were tested obtaining a good grafting percentage. Moreover, different types of cellulosic material are under study, including cellulose derived from agri-food waste. The obtained materials were characterized by SEM-EDX, FTIR spectroscopy, X-ray diffraction analysis, and X-ray photoelectron spectroscopy.

A direct disruptive mechanical interaction occurs with bacteria due to impaling with asymmetrical functionalized ZnO-NWs diffusing from the cellulose in presence of external stimuli (i.e. light) to facilitate their motion and interaction with bacteria [3]. Finally, we will present preliminary results on the photocatalytic activity of the ZnO-NWs/amino-cellulose composites and their antimicrobial effects against both Gram-positive and Gram-negative bacteria strains.

[1] M. K. Thakur, R. K. Gupta, and V. K. Thakur, *Carbohydr. Polym.* 111 (2014) 849-855

[2] H. Khanjanzadeh, R. Behrooz, N. Bahramifar, W. Gindl-Altmutter, M. Bacher, M. Edler, and T. Griesser, *Int. J. Biol. Macromol.* 106 (2018) 1288–1296

[3] G. Arrabito, G. Prestopino, P. G. Medaglia, V. Ferrara, G. Sancataldo, G. Cavallaro, F. Di Franco, M. Scopelliti, and B. Pignataro, *Colloids Surf. A: Physicochem. Eng. Asp.* 698 (2024) 134526

## Vanillin-enhanced polymers: a new frontier in antibacterial textiles for emergency services

Ana Arnaiz,<sup>a</sup> Miriam Trigo-López,<sup>a</sup> Sandra de la Parra,<sup>b</sup> Álvaro Miguel,<sup>a,c</sup> Natalia Fernández-Pampín,<sup>b</sup> Carlos Rumbo,<sup>b</sup> José Miguel García,<sup>a</sup> and Saúl Vallejos<sup>a</sup>

<sup>a</sup> Chemistry Department, Faculty of Sciences, Universidad de Burgos, Plaza de Misael Bañuelos s/n, 09001 Burgos, Spain

<sup>b</sup> International Research Center in Critical Raw Materials for Advanced Industrial Technologies (ICCRAM), Universidad de Burgos, Plaza Misael Bañuelos s/n, 09001, Burgos, Spain

<sup>c</sup> Facultad de Ciencias, Universidad Autónoma de Madrid, Calle Francisco Tomás y Valiente 7, Fuencarral-El Pardo, 28049 Madrid, Spain

E-mail: [anaaa@ubu.es](mailto:anaaa@ubu.es)

Aramids, renowned for their exceptional high-performance properties, are the materials of choice for critical applications that require strength and durability. These polymers are employed in the manufacturing of personal protective equipment, aerospace components, and industrial filters, among other essential uses. However, significant challenges arise in contexts where frequent cleaning of these materials is impractical. This limitation fosters the proliferation of bacteria, a particularly concerning issue in textiles. In such scenarios, maintaining hygiene and preventing bacterial contamination becomes a complex and crucial task. In the realm of textiles for emergency personnel, aromatic polyamides have been introduced to impart intrinsic bactericidal activity while preserving their mechanical and thermal properties.

This study presents a straightforward and scalable method for preparing aramid-coated textiles and films endowed with inherent bactericidal activity, achieved through the reaction of aramids with vanillin. The functionalization of aramids with bactericidal groups not only preserves the high-performance characteristics of commercial aramids but also significantly enhanced their mechanical properties. Tensile tests revealed a 50% increase in Young's modulus compared to commercial *m*-aramid, accompanied by thermal performance comparable to commercial *m*-aramids.

Following the UNE-EN ISO 20743:2022 standard, these coated textiles were evaluated as bactericidal materials demonstrated notable effectiveness, with A parameters (antibacterial activity) of 4.31 for *Staphylococcus aureus*, and 3.44 for *Klebsiella pneumoniae*. Additionally, the antibacterial efficacy tests yielded excellent results, inhibiting bacterial growth by 99.43% for *S. aureus* and 99.26% for *K. pneumoniae*, after five thorough washes of the fabrics, adapting to the practical demands of emergency personnel. Finally, skin compatibility tests, performed using reconstructed human epidermis, confirmed the non-irritating nature of these materials, ensuring their safety for extended skin contact.

In conclusion, this study underscores the potential of vanillin-functionalized aromatic polyamides to enhance hygiene and durability in textiles intended for critical applications, providing an effective and practical solution for emergency personnel.

## Enhancing marine bioproducts in the creation of collagen and gelatin-based hydrogels with tunable properties for wound healing applications

Francesca Basso,<sup>a,b</sup> Giovanni Perotto,<sup>a</sup> Marco Contardi,<sup>c,a</sup> and Athanassia Athanassiou,<sup>a</sup>

<sup>a</sup> Smart Materials, Istituto Italiano di Tecnologia, Genova 16163, Italy

<sup>b</sup> Dipartimento di Informatica Bioingegneria, Robotica e Ingegneria dei Sistemi, Università degli studi di Genova, Italy

<sup>c</sup> Department of Earth and Environmental Sciences (DISAT), University of Milan–Bicocca, Italy

E-mail: [francesca.basso@iit.it](mailto:francesca.basso@iit.it)

Hydrogels are three-dimensional, hydrophilic polymer networks that can absorb and retain a large amount of water or biological fluids within their structure without dissolving [1]. Collagen and gelatin are two excellent candidates for creating hydrogels for biomedical applications, thanks to their biomimetic properties [2]. However, a drawback is their solubility in water at 37 °C. This poses a limitation in their application in the biomedical field. Therefore, to use these two proteins at body temperature, it is necessary to covalently crosslink them. Microbial transglutaminase (mTG) was selected for a harmless enzymatic crosslinking, minimizing undesirable effects associated with potential chemical crosslinker residues and ensuring enhanced biocompatibility. The collagen type used in this study is noteworthy. Fish swim bladders, often discarded as waste, are a promising source of collagen [3]. We demonstrated that a combination of gelatin and swim bladder collagen crosslinked with mTG can be utilized to create hydrogels suitable for biomedical applications. It has been proved that hydrogel properties can be substantially tuned by varying the degree of crosslinking and the matrix composition. This is important because different biomedical applications may require hydrogels with specific properties such as mechanical strength or swelling behaviour. It has been demonstrated that swelling and gel fraction properties can be tuned by varying the enzyme concentration while the mechanical properties can be modified by changing the gelation time. The developed hydrogels cover a wide range of swelling values. Moreover, hydrogels are soft hydrogels with Young's modulus values ranging from 0.5KPa to 10KPa. Hydrogels were loaded with a natural antioxidant polyphenol to understand the release performance and the fitting of the drug release profile in vitro showed a diffusion-controlled drug release mechanism. Finally, the developed hydrogel has been validated as a biomaterial for use in wound healing applications through in vitro biocompatibility tests followed by in vivo trials.

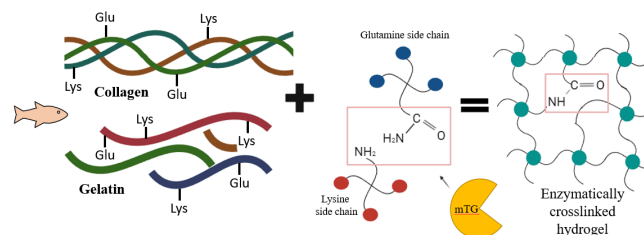

## Activating titanium surface by cerium coatings: biocompatibility, resistance in simulated inflammatory conditions, and antibacterial performance

Chiara Frezza, Monica Orsini, Susanna Romano, Giovanni Sotgiu, and Serena De Santis

Department of Industrial, Electronic and Mechanical Engineering, Roma Tre University, Via Vito Volterra 62, 00146 Rome, Italy.

E-mail: [chiara.frezza@uniroma3.it](mailto:chiara.frezza@uniroma3.it)

Despite the many advantages offered by titanium and its alloys as biomaterials for hard tissue replacement, poor osseointegration of the implants, bacteria adhesion, and excessive inflammatory response are some challenges that still need to be addressed. Nanoscale modifications and the activation of surfaces with multifunctional materials such as cerium oxide (ceria) can promote cell adhesion and the formation of a solid interface between bone and implant, while imparting antibacterial activity and improving corrosion resistance [1,2]. In the present work, active coating on titanium surfaces are realized exploiting a simple layer-by-layer drop casting technique. Surface composition, electrochemical response in simulated inflammatory conditions, biocompatibility, and antibacterial properties are evaluated as a function of cerium surface content.

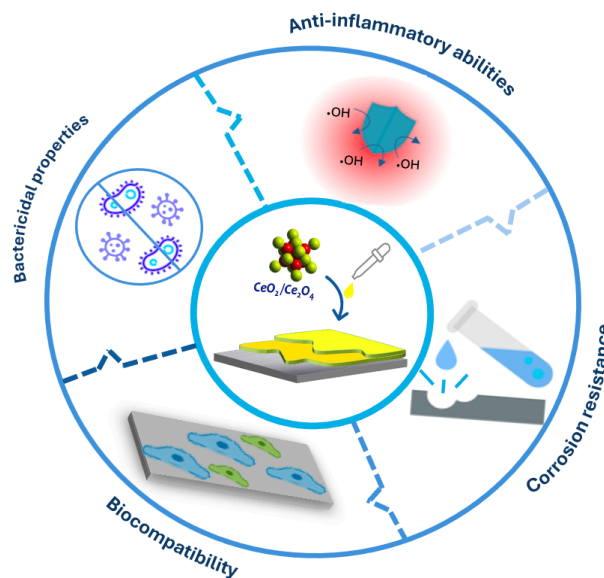

**Figure 1:** Surface properties of functionalized titanium

[1] S. De Santis, R. Varricchio, A. Ceccucci, G. Sotgiu, A. Di Masi, G. Magna, S. Sennato, and M. Orsini, *ACS Biomater. Sci. Eng.* 9 (2023) 3262-3272

[2] S. De Santis, G. Sotgiu, F. Porcelli, M. Marsotto, G. Iucci, M. Orsini, *Nanomaterials* 11 (2021) 445

## Synthesis of gold-gadolinium alloy nanoparticles via Laser Ablation in Liquid for biomedical applications

Sara Cazzola, and Vincenzo Amendola

Department of Chemical Sciences, Università di Padova, via Marzolo 1, 35131 Padova, Italy

E-mail: sara.cazzola@unipd.it

Despite progress in conventional cancer treatments, the rising incidence and mortality related to cancer remain a persistent global challenge. Obstacles such as the non-specific distribution of anticancer drugs, cytotoxicity, side effects, and resistance to treatments can be potentially overcome by an innovative nanomedical approach, by using engineered nanomaterials.

In this context bimetallic alloy nanoparticles (NPs) emerged as an attractive prospect, designed to combine and exploit the properties of each element for specific medical treatments [1]. As an example, gold-gadolinium (Au-Gd) NPs include from one side the ideal properties of gold in computed tomography (CT) imaging and as a radiosensitizer in X-ray radiotherapy [2]. From the other side, gadolinium is well-known for being paramagnetic, and this is useful as a  $T_1$  contrast agent in magnetic resonance imaging (MRI) when ionically complexed, and as a  $T_2$  contrast agent in the form of NPs [3].

Here we describe the synthesis of bimetallic Au-Gd NPs with different composition using laser ablation in liquid (LAL). LAL allows the creation of alloy NPs even under thermodynamically unfavorable conditions. These NPs were studied for theranostic applications, aimed at combining imaging techniques, such MRI and CT, with *in vitro* radiotherapy experiments. The physico-chemical properties of the Au-Gd NPs indicate their potential interest also for other more advanced functions such as selective targeting of cancer cells and drug delivery.

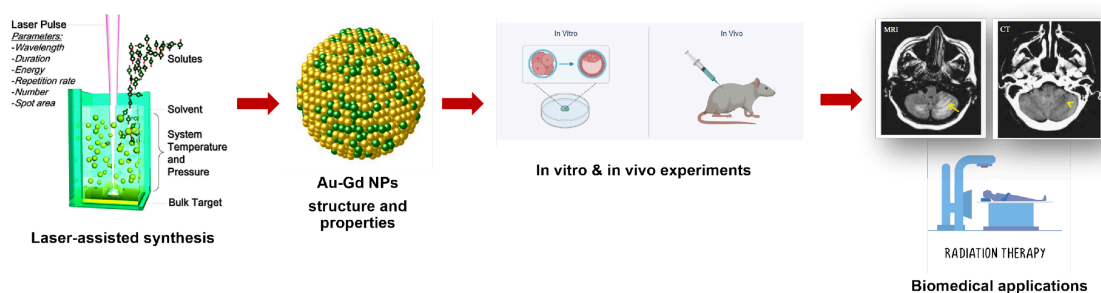

**Figure 1:** LAL synthesis of NPs for theranostic applications.

[1] S. Scaramuzza, S. Agnoli, and V. Amendola, *Phys. Chem. Chem. Phys.* 17 (2015) 28076–28087

## Synthesis and characterization of succinylated pectin

Stefano Liotino,<sup>a,b</sup> Stefania Cometa,<sup>c</sup> Stefano Todisco,<sup>d</sup> Antonio Salomone,<sup>a</sup> and Elvira De Giglio<sup>a,b</sup>

<sup>a</sup> Dipartimento di Chimica, Università degli Studi di Bari "Aldo Moro", Via Edoardo Orabona 4, 70125-Bari, Italia

<sup>b</sup> Consorzio Interuniversitario Nazionale per la Scienza e Tecnologia dei Materiali "INSTM", Via Giuseppe Giusti 9, 50121-Firenze, Italia

<sup>c</sup> Jaber Innovation s.r.l., Via Calcutta 8, 00100-Roma, Italia

<sup>d</sup> Dipartimento di Ingegneria Civile, Ambientale, del Territorio, Edile e di Chimica "DICATECh", Università Politecnica di Bari, Via Orabona 4, 70125-Bari, Italia

E-mail: [stefano.liotino@uniba.it](mailto:stefano.liotino@uniba.it)

Pectin is a polysaccharide with many applications in food, pharmaceutical and cosmetic industries, but also in the fields of nutraceuticals, drug delivery, tissue engineering and packaging. The wide application depends on its ability to swell, emulsify or stabilize. Furthermore, its non-toxic, biocompatible and biodegradable nature is useful for biomedical applications [1]. Different functional groups (-COOCH<sub>3</sub>, -COOH and -OH) could react differently, modulating pectin's properties [2]. In this study, we synthesized, for the first time, pectin succinate from succinic anhydride and pectin in water in presence of DMAP, Figure 1, to obtain a pectin derivative for potential biomedical applications. The succinylation was confirmed by FT-IR, <sup>1</sup>H NMR and <sup>1</sup>H COSY NMR spectroscopies, and the thermal properties were studied by TGA and DSC analyses. As further confirmation, the reaction between galacturonic acid sodium salt and succinic anhydride was carried out as model reaction in the same experimental condition. The main evidence that the reaction occurs was given by the comparison of NMR spectra of the succinate pectin and succinate galacturonic acid sodium salt. In these NMR spectra, two signals observed at 2.6 and 2.5 ppm, both with equal integral areas and showing mutual coupling, could be assigned to the protons of the two -CH<sub>2</sub>- groups in the succinate moiety attached to the hydroxyl groups of pectin.

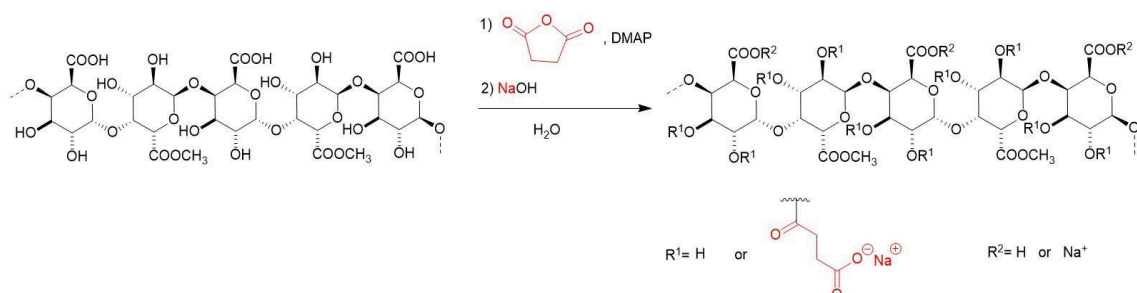

**Figure 1:** Succinylation reaction of pectin

[1] N. Aqdas, Z. Nazli, J. Akram, I. Rasul, A. Mansha, N. Yaqoob, R. Iqbal, et al., *International Journal of Biological Macromolecules* 101 (2017) 254–72

[2] W. Hendryk, K. Geitel, H. Qi, e T. Heinze, *BioResources* 16(4) (2021) 8457-8488 .

## Transient supramolecular fibrillation and catalytic regulation of peptide amphiphiles driven by ATP

David Cappelletti, and Luka Đorđević

*Department of Chemical Sciences, University of Padova, via Marzolo 1, 35131-Padova, Italy*

*E-mail: [david.cappelletti@phd.unipd.it](mailto:david.cappelletti@phd.unipd.it)*

Living systems can exploit time-dependent dynamic self-assembly via energy dissipation pathway to accomplish spatiotemporal regulation of various important functions [1]. Taking inspiration from nature to design supramolecular systems with ‘life-like’ properties is an arduous mission. In this regard, this contribution presents a novel self-assembled system which shows lifetime controllability.

The addition of triple-negatively charged ATP to a solution of positively charged C16V3A3K3 (peptide amphiphile, PA), at a concentration above the critical micellar concentration of the latter, results in the formation of ATP-templated nanofibers through charge-screening. However, when in the system is present also an ATPase, an enzyme that hydrolyzes ATP into AMP and two phosphate ions ( $P_i$ ), the electrolyte is consumed. As a result of lower charge screening conditions, the nanofibers gradually dissociate into micelles, thus leading to a control of the lifetime of the self-assembled nanofibers (Figure 1).

Furthermore, the transient formation of ATP-templated nanostructures offers a new possibility to control chemical reactivity in the time domain [2,3]. In this regard, we also investigated the catalytic activity of the transient system through two model reactions: a retro aldol reaction and a deacetylation reaction. In both cases, in the presence of ATPase, the addition of ATP to the PA solution temporarily downregulates the catalytic activity of PA. Indeed, the enzyme-driven consumption of ATP is observed to lead again to an increase in the formation of the products due to the gradual disaggregation of the ATP-templated nanofibers.

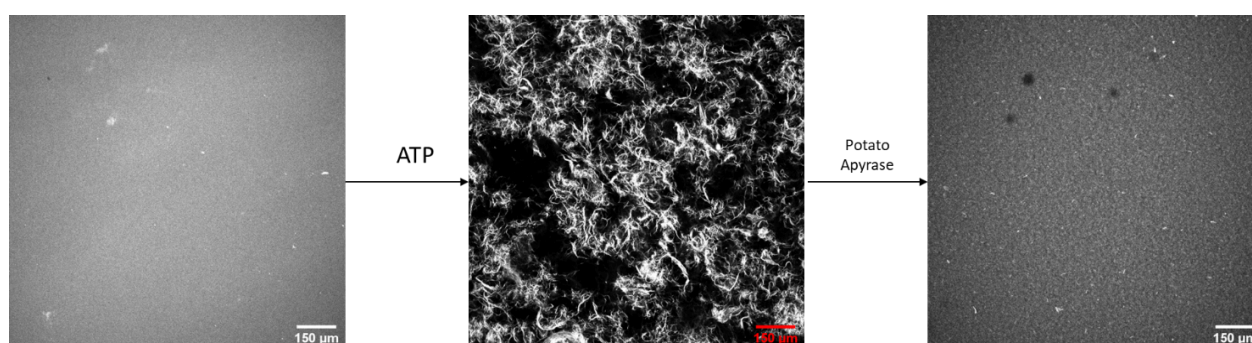

**Figure 1:** ATP-driven transient nanofibers formation (TEM images).

- [1] A. Desai, and T. J. Mitchison, *Annu. Rev. Cell Dev. Biol.* 13 (1997) 83-117.  
[2] C. Pezzato, and L. J. Prins, *Nat. Commun.* 6 (2015) 7790.  
[3] S. Maiti, I. Fortunati, C. Ferrante, P. Scrimin, and L. J. Prins, *Nat. Chem.* 8 (2016)

## High-pormance carboxylated Polymers of Intrinsic Microporosity (PIMs) with Gas Transport Properties.

Carmela Astorino<sup>a</sup>, Eugenio De Nardo<sup>a</sup>, Stefania Lettieri<sup>a</sup>, Giuseppe Ferraro<sup>a</sup>, Mattia Bartoli<sup>b</sup> and Sergio Bocchini<sup>a,b</sup>

<sup>a</sup> Department of Applied Science and Technology, Politecnico di Torino, Corso Duca degli Abruzzi 24, 10129, Italy

<sup>b</sup> Center for Sustainable Future Technologies, Istituto Italiano di Tecnologia, Via Livorno 60, 10144, Italy

E-mail: [carmela.astorino@polito.it](mailto:carmela.astorino@polito.it)

Polymers of intrinsic microporosity (PIMs) represent a novel class of materials characterized by their rigid backbone structure, leading to the formation of micropores. These micropores facilitate enhanced gas diffusion and function as selective molecular sieves, making PIMs particularly suitable for gas separation processes [1]. It has been previously reported the partial hydrolysis of the -CN group of PIM-1 to obtain carboxylated PIMs (caPIMs) improves gas separation performance.

In this study, the hydrolysis process was optimized by varying reaction times in a microwave reactor. Data indicated that partial hydrolysis to an amide group is completed after one hour, with complete conversion to a carboxylic acid observed after four hours [2]. The resulting caPIMs demonstrated improved gas separation performance due to the combination of intrinsic microporosity and the introduction of carboxylic acid groups, which enhance interactions with gases. Thermogravimetric analysis (TGA) revealed distinct degradation steps for the composite membranes, correlating the degree of hydrolysis with thermal properties. Fourier-transform infrared spectroscopy (FTIR) confirmed the presence of carboxylic acid and amide functionalities, with a gradual increase in carboxylate content over extended reaction times (Figure 1). The modified polymers exhibited exceptional performance in gas separation, particularly for CO<sub>2</sub>, due to increased solubility selectivity and enhanced diffusivity. This work highlights the potential of microwave-assisted hydrolysis for efficiently producing highly carboxylated PIMs, providing a sustainable and effective approach for developing advanced gas separation membranes [3].

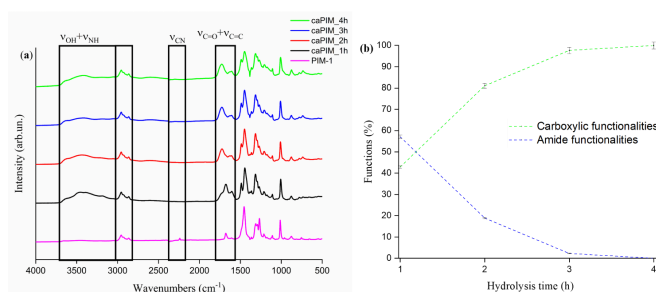

**Figure 1:** Summary of a) FT-IR spectra of hydrolyzed PIM-1 and b) amount of carboxylic and amide species.

## Unraveling exchange coupling in ferrites nano-heterostructures

Pierfrancesco Maltoni<sup>a,b,c</sup>

<sup>a</sup> *Dipartimento di Chimica e Chimica Industriale, Università degli Studi di Genova, Via Dodecaneso 31, Genova, 1-16146 Italy*

<sup>b</sup> *Istituto di Struttura della Materia, nM<sup>2</sup>-lab, Consiglio Nazionale delle Ricerche, Monterotondo Scalo, Rome, 00015 Italy*

<sup>c</sup> *Department of Materials Science and Engineering, Uppsala University, Box 35, Uppsala, 751 03 Sweden*

E-mail: [Pierfrancesco.maltoni@edu.unige.it](mailto:Pierfrancesco.maltoni@edu.unige.it)

Functional oxide nanocomposites (NCs) offer tunable magnetic functionalities by combining multiple magnetic phases. This study explores a sol-gel synthetic approach to prepare bi-magnetic NCs with tailored magnetic properties.

A series of ferrite-based NCs, comprising a hard  $\text{SrFe}_{12}\text{O}_{19}$  (SFO) phase superexchange-coupled with a less hard  $\text{CoFe}_2\text{O}_4$  (CFO) ferrite, undergoes controlled annealing, resulting in epitaxial growth at the SFO/CFO interface [1]. Advanced electron microscopy confirms the morphology, revealing strong magnetic coupling at the interface (see Figure 1). Magnetic measurements demonstrate that this coupling influences the magnetization reversal and defines the critical size limit for robust magnetic coupling.

In addition to exploring nanoscale interactions, bulk magnets were successfully prepared using spark plasma sintering (SPS) to consolidate the ferrite-based NCs. This technique preserves the nanoscale structure while enhancing the macroscopic magnetic properties, making it suitable for high-performance applications. The SPS-consolidated bi-magnetic composites exhibit enhanced magnetic strength, providing valuable insights for optimizing magnetic properties in technological applications.

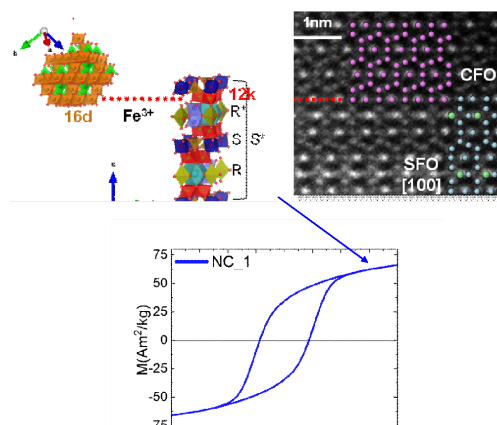

**Figure 1:** High-resolution HAADF-STEM image of a typical SFO/CFO interface in NC\_1 and corresponding magnetic hysteresis loop at 300K.

[1] P. Maltoni, G. Barucca, B. Rutkowski, M. C. Spadaro, P. E. Jönsson, G. Varvaro, N. Yaacoub, J. A. De Toro, D. Peddis, R. Mathieu, *Small* 20 (2024) 2304152.

---

## Poster presentations

- POS001 - DI LIBERTO Giovanni (UniMiB)
- POS002 - FORNACIARI Charlotte (UniPV)
- POS003 - MOMOLI Caterina (UnivAQ)
- POS004 - SCIARRETTA Sara (UnivAQ)
- POS005 - TAGLIERI Francesco
- POS006 - BERGOMI Andrea (UniMI)
- POS007 - CINO Luigi (UniPA)
- POS008 - ROSELLI Vincenzo (UniBA)
- POS009 - STOCCHETTI Sara (UniCA)
- POS010 - RUSSO Ludovica (UniNA)
- POS011 - TONON Giovanni (UniVe)
- POS012 - MATTEUCCI Federica (UniCAM)
- POS013 - PETRAROLO Giovanni (UniPI)
- POS014 - PIERGENTILI Alessia (UNICAM)
- POS015 - PITASI Giovanna (UniMe)
- POS016 - GALLO Marica (UniNA)
- POS017 - HÖNER Janina Carolin (UniHAN)
- POS018 - CAREDDU Fabrizio (UniTO)
- POS019 - SERPICO Carmen (UniNA)
- POS020 - NOWAK Ylenia (CNR-ICCOM)
- POS021 - GRILLO Andrea (UniNA)
- POS022 - EMANUELE Manuel (UniNA)
- POS023 - BALOCCO Sara (UniNA)
- POS024 - ROHRBECK Pascal (MPIP)
- POS025 - SCHILLING Monja (HIU)
- POS026 - ARDUINO Ilaria (UniBA)
- POS027 - FIORE Ambra M. (UniBA)
- POS28 - SAMBUCCI Matteo (UniRM1)
- POS29 - MAROTTA Angela (UniNA)
- POS30 - ROMEO Isabella (UniMagnaGraecia)

## Modelling single-atom catalysis

Giovanni Di Liberto

<sup>a</sup> *Department of Materials Science, University of Milan - Bicocca, Via Roberto Cozzi 55, 20125 Milano, Italy*  
*E-mail: [giovanni.diliberto@unimib.it](mailto:giovanni.diliberto@unimib.it)*

Single Atom Catalysts (SACs) are emerging as new frontier in the field. Computational chemistry offers a valid framework to access the atomistic details of electrocatalytic processes and to rationalize or even predict novel systems. Recently, a lot of attention has been dedicated to the reactions of evolution and conversion of molecular hydrogen and oxygen from or to liquid water. The activity of SACs is usually rationalized or predicted using the Computational Hydrogen Electrode (CHE) approach, where the free energy of key intermediates adsorbed is used to explain the catalytic activity.

In this presentation we discuss the key ingredients to model electrocatalytic processes on SACs. SACs differ substantially from metal surfaces and can be considered analogues of coordination compounds. In coordination chemistry, at variance with metal surfaces, stable complexes of hydrogen and oxygen can form [1]. We show that the same can occur on SACs and their formation may change the kinetics of the process. We propose an approach to predict the stability of SACs under working conditions of pH and applied voltage [2]. Needless to say, the adopted DFT functional affects the accuracy of the predictions, and we show evidence suggesting that self-interaction corrected schemes should be adopted [3]. DFT numerical simulations demonstrate that these ingredients may lead to different conclusions about the activity of SACs in the water splitting reaction. This work provides an example of the important analogies between the chemistry of SACs and that of coordination compounds, and underlines the key ingredients to be accounted when attempting to provide predictions with computational frameworks.

[1] G. Di Liberto, L. A. Cipriano, G. Pacchioni, *J. Am. Chem. Soc.* 143 (2021), 40321; *ACS Catalysis* 19 (2022), 11682; I. Barlocco, L.A. Cipriano, G. Di Liberto, G. Pacchioni *J.Catal.* 417, (2023) 351.

[2] G. Di Liberto et al, *Curr. Opin. Electrochem* 101343 (2023); *J. Power. Sources* 556 (2023), 232492; *Adv. Mater.* 35, (2023) 2307150.

[3] G. Di Liberto, L. Giordano, G. Pacchioni *ACS Catalysis* 14, (2024) 45; I. Barlocco, L.A. Cipriano, G. Di Liberto, G. Pacchioni. *Adv. Theo. & Simul.* 6, (2023) 2200513.

## Programmable copolymerization of oxiranes driven by a benign acetate-based catalyst

Charlotte Fornaciari,<sup>a,b</sup> Olivier Coulembier,<sup>b</sup> and Dario Pasini<sup>a</sup>

<sup>a</sup> Department of Chemistry and INSTM Unit, University of Pavia, Viale Taramelli, 12, 27100 Pavia, Italy

<sup>b</sup> Laboratory of Polymeric and Composite Materials (LPCM), Center of Innovation and Research in Materials and Polymers (CIRMAP), University of Mons, Place du Parc, 20, 7000 Mons, Belgium

E-mail: [charlotte.fornaciari01@universitadipavia.it](mailto:charlotte.fornaciari01@universitadipavia.it)

Polyethers produced by Ring-Opening Polymerization (ROP) of oxiranes are extremely versatile polymers that serve as key components in a broad spectrum of everyday products [1]. Our group has recently demonstrated the potential of potassium acetate (KOAc) complexed by 18-crown-6 ether (18C6) as a robust and benign catalytic system for the preparation of poly(propylene oxide) (PPO) in a controlled manner at room temperature and under solvent-free conditions [2].

To gender chemical functionalities along the PPO chain, a detailed investigation into the oxyanionic copolymerization of propylene oxide (PO) with allyl glycidyl ether (AGE) from benzyl alcohol (BnOH) activated with 18C6/KOAc complex is discussed. We demonstrated that the 18C6/KOAc complex efficiently promotes the copolymerization of both oxiranes, leading to well-defined polyethers with varied comonomer content and low dispersity values ( $D_M < 1.2$ ) [3]. The reactivity ratios of comonomers determined by <sup>1</sup>H NMR kinetics and the structural information derived from a combination of analyses revealed a quasi-alternating copolymerization profile. Furthermore, diblock and gradient PO/AGE copolymers were synthesized by controlled sequential additions of monomers at different reaction periods. The comparison between the quasi-alternating-type PO/AGE microstructure and diblock or gradient revealed significant differences, to confirm the different monomer incorporation into structurally distinct copolymers.

These results underscore the great potential of 18C6/KOAc-mediated copolymerization process for the controlled synthesis of copolymer with specific topologies, including highly sought quasi-alternating microstructures, in response to the type of “monomer diet” used during the reaction.

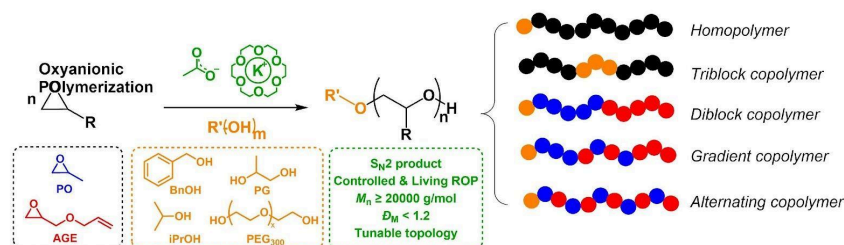

**Figure 1:** 18C6/KOAc complex-catalyzed ROP system.

[1] J. Herzberger, K. Niederer, H. Pohlitz, J. Seiwert, M. Worm, F. R. Wurm, and H. Frey. *Chem. Rev.* 116 (2016) 2170–2243.

[2] C. Fornaciari, D. Pasini, and O. Coulembier. *Macromol. Rapid Commun.* 43 (2022) 2200424.

[3] C. Fornaciari, V. Lemaure, D. Pasini, and O. Coulembier. *Commun Chem.* 6 (2023) 235.

## A study on the chemoselectivity of 2-aminobenzaldehyde self-condensation promoted by gold (III)

Caterina Momoli,<sup>a</sup> Antonio Arcadi,<sup>a</sup> Marco Chiarini,<sup>b</sup> Valerio Morlacci,<sup>a</sup> and Laura Palombi<sup>a</sup>

<sup>a</sup> Dipartimento di Scienze Fisiche e Chimiche, Università degli Studi dell'Aquila, Via Vetoio, 67100 Coppito, Italy.

<sup>b</sup> Dipartimento di Bioscienze e Tecnologie Agroalimentari e Ambientali, Università degli Studi di Teramo, Via R. Balzarini, 64100 Teramo, Italy  
E-mail: caterina.momoli@graduate.univaq.it

2-Aminobenzaldehydes are versatile building blocks in organic synthesis enabling a variety of bond-forming strategies. These molecules are also well-known for their high reactivity in self-condensation reaction [1]. Indeed, for over 80 years, this domino reaction has garnered interest due to the variety of nitrogen-containing polyheterocycles it can produce. In addition, the process plays a considerable role in synthesizing macrocyclic ligands using transition metal ions as templates [2].

Despite being intrinsically straightforward, controlling the chemoselectivity of the self-condensation presents a significant challenge, as it is strongly influenced by the stereo-electronic effect of the substituents and the reaction parameters such as solvent, temperature and nature of the acidic catalyst [3].

The following study investigates the reaction catalyzed by gold (III) salts in the presence of non-innocent alcoholic solvents for the synthesis of trimers **A**, and in the presence of nitrogen nucleophiles for the synthesis of derivatives **B**.

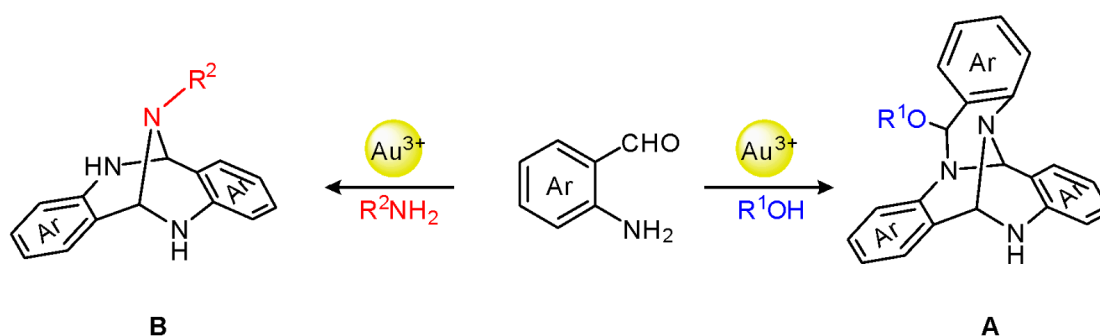

**Figure 1:** Self-condensation products addressed in this study.

[1] D. H. Busch, S. C. Cummings, *Inorg. Chem.* (1971), 10, 6, 1220–1224.

[2] A. J. Jircitano, S. O. Sommerer, J. J. Shelley, B. L. Westcott Jnr and I.-H. Suh, *Acta Cryst.* (1994), 50, 445-447.

[3] D. Mao, J. Tang, W. Wang, S. WU, X. Liu, J. Yu, L. Wang; *J. Org. Chem.* (2013), 78, 24, 12848-12854.

## Discovering new dioxovanadium (V) complexes for DODH reaction

Sara Sciarretta, Elèna Di Gregorio, Andrea Di Giuseppe, and Marcello Crucianelli

<sup>1</sup>University of L'Aquila, via Vetoio ("A.C. De Meis" building), 67100 L'Aquila, Italy;  
E-mail: sara.sciarretta1@student.univaq.it

The depletion of fossil fuel has highlighted interest in the use of biomass. Small molecules derived from biomass are all rich in oxygen group, therefore methods are needed to remove these groups. Metal-catalyzed deoxydehydration generates an olefin from a vicinal diol. The pioneering work was achieved by Andrews et al. in 1996 and thereafter, the DODH reactions based on rhenium catalysts has been largely expanded. Despite the achievements made with rhenium, it is a very expensive metal, and attention is shifting towards the use of cheaper and more abundant metals, such as vanadium.

Our work therefore focused on the synthesis of three oxidovanadium(V) complexes with ONO-type ligands, to be tested on the DODH reaction. [1].

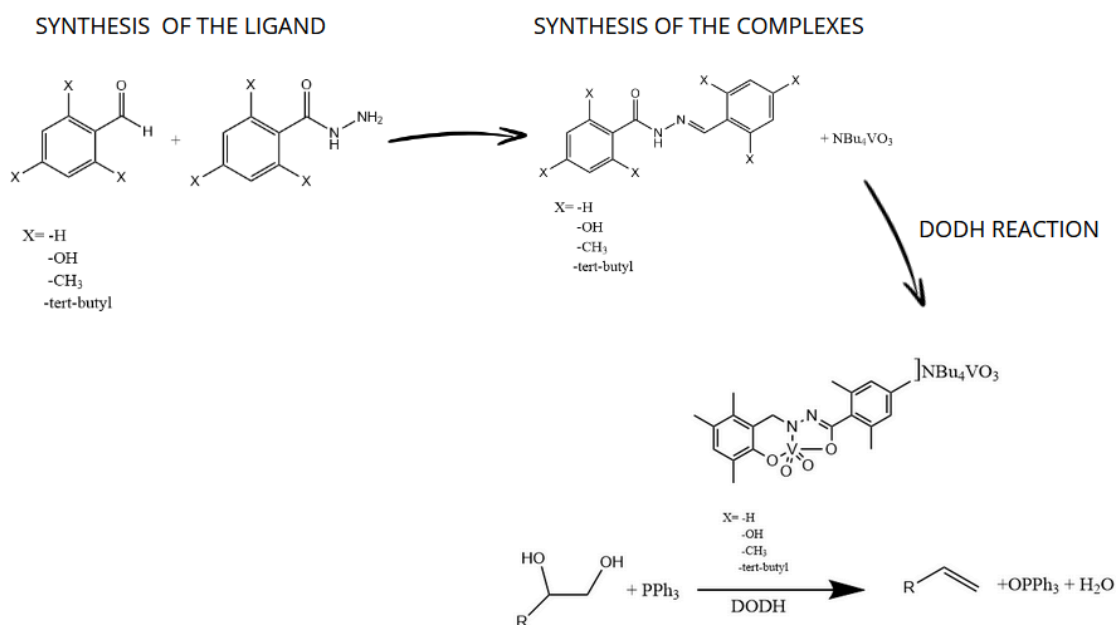

**Figure 1:** Overall schematization of the reactions

## H/D exchange of amine compounds catalyzed by cationic Iridium (III)-Cp\* complexes bearing dioxime ligands using D<sub>2</sub>O as deuterium source

Francesco Taglieri,<sup>a</sup> Andrea Di Giuseppe,<sup>a</sup> Marcello Crucianelli, and <sup>a</sup> Lorenzo Biancalana<sup>b</sup>

<sup>a</sup> *Università dell'Aquila, Dipartimento di Scienze Fisiche e Chimiche, Via Vetoio, I-67100 L'Aquila, Italy.*

<sup>b</sup> *Università di Pisa, Dipartimento di Chimica e Chimica Industriale, Via G. Moruzzi 13, I-56124 Pisa, Italy.  
E-mail: francesco.taglieri@graduate.univaq.it*

The H/D exchange reaction facilitates the incorporation of deuterium into organic structures, which is essential for various applications such as mechanistic studies and improving the ADME properties of drugs [1]. Amino groups are ubiquitous in APIs, nevertheless are prone to enzymatic cleavage at their  $\alpha$  and  $\beta$  positions. Replacing protium with deuterium at these positions enhances their stability and improves drug pharmacokinetics [2]. However, this process faces challenges related to deuterium sources and catalytic systems. Recent research has focused on developing practical methods using efficient catalysts and cost-effective deuterium sources. In this regard, new Iridium (III)-Cp\* based catalysts with dioxime ligands [3] have been synthesized and tested for the H/D exchange reaction on amine substrates, using D<sub>2</sub>O as an economical and safe deuterium source.

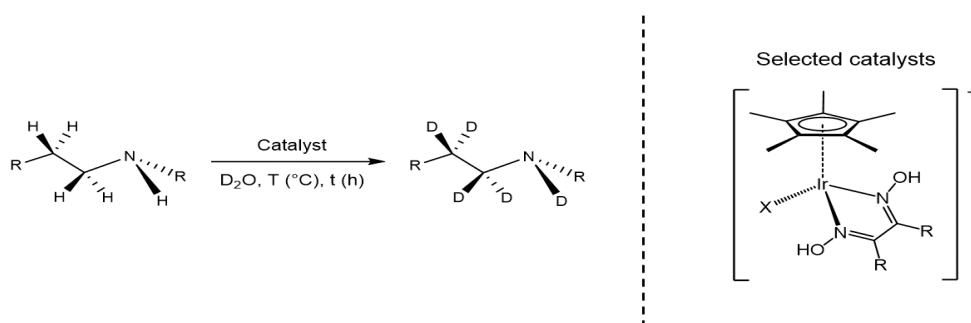

**Figure 1:** Representative scheme of this work.

[1] X. L. Xu, W. Zhang, and G. W. Rao, *Curr. Med. Chem.* 30 (2023) 4096-4129

[2] B. Chatterjee, V. Krishnakumar, and C. Gunanathan, *Org. Lett.* 18 (2016) 5892-5895

[3] R. Colaiezzi, C. Saviozzi, N. Di Nicola, S. Zacchini, G. Pampaloni, M. Crucianelli, F. Marchetti, and L. Biancalana, *Catal. Sci. Technol.* 13 (2023) 2160-2183

## Measuring the toxicity of black crusts with oxidative potential assays

Andrea Bergomi,<sup>a,b</sup> Elisa Festa,<sup>a</sup> Valeria Comite,<sup>a</sup> and Paola Fermo<sup>a</sup>

<sup>a</sup> Department of Chemistry, Università degli Studi di Milano, Via Golgi 19, 20133-Milano, Italy

<sup>b</sup> Consorzio Interuniversitario Nazionale per la Scienza e la Tecnologia dei Materiali (INSTM), 50121-Firenze, Italy.

E-mail: [andrea.bergomi@unimi.it](mailto:andrea.bergomi@unimi.it)

Oxidative potential (OP) assays are currently being used to measure the toxicity of particulate matter (PM) towards human beings by simulating the oxidative stress induced by the particles in contact with the respiratory system [1]. However, PM is also responsible for the formation of black crusts, which are degradation layers formed on the surface of monuments, statues, and other works of art with a carbonate substrate, by acting as a catalyst in the sulphation process [2]. Therefore, the particles remain embedded in the structure and can accumulate through time. Applying OP tests on black crusts enables to assess their toxicity, which is strictly related to the surrounding atmospheric conditions.

Two of the most widespread OP assays (ascorbic acid and dithiothreitol) were applied to a series of black crusts from the Monumental Cemetery of Milan (Figure 1). Analyses were performed separately on the black crust, the underlying altered substrate, and the unaltered substrate. The ascorbic acid assay revealed to be more sensitive and suitable for these types of samples compared to the dithiothreitol method. The results obtained with the former test reveal higher OP values for the black crust and the altered substrate as opposed to the unaltered substrate. No statistically significant differences were observed between the top layer of black crust and the underlying altered substrate.



**Figure 1:** Funerary monument. The red circle indicates the black crust detachment.

[1] A. Bergomi, E. Carrara, E. Festa, C. Colombi, E. Cuccia, B. Biffi, V. Comite and P. Fermo, *Atmosphere* Vol. 15(7) (2024) 772.

[2] V. Comite, A. Bergomi, P. Fermo, C. Castellano, M. Borelli, C.A. Lombardi, M. Formenti, C. Cavaterra and C. Della Pina, *IMEKO TC4 International Conference on Metrology for Archaeology and Cultural Heritage* (2023) 1095–1100.

## Adsorption of dyes by ionic-liquid doped polymer membrane

Luigi Cino, Salvatore Marullo, and Francesca D'Anna

Dipartimento STEBICEF, Università degli Studi di Palermo, viale delle Scienze ed. 17, 90128-Palermo, Italy  
E-mail: [luigi.cino01@unipa.it](mailto:luigi.cino01@unipa.it)

Water pollution by emerging contaminants such as dyes, pesticides, and pharmaceuticals is a pressing global environmental challenge. Dyes pose a serious threat to humans and to the ecosystem due to its accumulation in water sources which can lead to chronic health problems and endanger aquatic life. It is therefore crucial to properly remove them from water.

In this context, this study focuses on the preparation of polymeric membranes doped with non-conventional solvents like ionic liquids (ILs), with the aim of effectively removing dyes from wastewater<sup>[1]</sup>.

The membranes were prepared using a biodegradable polymer such as poly(3-hydroxybutyrate), (PHB), and hydrophobic ILs (Figure 1).

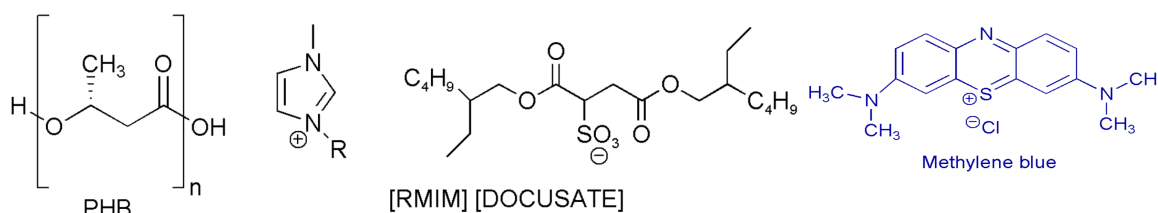

Figure 1

We studied the effect of various parameters such as the initial concentration of dyes, sorbent dosage, contact time, pH, ionic strength, swelling and temperature<sup>[2]</sup>.

The results obtained demonstrated an high removal efficiency for various dyes, with values mostly higher than 90%. The recyclability of the membranes was also studied.

**Acknowledgement:** We thank MUR for funding, SiciliAn MicronanOTech Research And Innovation Center "SAMOTHRACE" (MUR, PNRR-M4C2, ECS\_00000022), spoke 3 - Università degli Studi di Palermo "S2-COMMs - Micro and Nanotechnologies for Smart & Sustainable Communities". The funding source had no role in analysis, design, interpretation of results and report writing.

[1] S.-Q. Cong, B. Wang, H. Wang, Q.-C. Zheng, Q.-R. Yang, R.-T. Yang, Q.-L. Li, W.-S. Wang, X.-J. Cui, and F.-X. Luo, *Int J Biol Macromol*, (2024), 256, 128233.

[2] Saif-ur-Rehman, M. Shozab Mehdi, M. Fakhar-e-Alam, M. Asif, J. Rehman, R. A. Alshgari, M. Jamal, S. Uz Zaman, M. Umar, S. Rafiq, N. Muhammad, J. bin Fawad, and S. A. Shafiee, *Molecules*, (2023), 28, 716

---

## POS008

### Sustainable valorization of grape pomace as source of nutraceuticals

Vincenzo Roselli,<sup>a</sup> Lucia Gambacorta,<sup>b</sup> Rosalba Leuci,<sup>a</sup> Antonio Laghezza,<sup>a</sup> Vincenzo Tufarelli,<sup>c</sup> and Luca Piemontese<sup>a</sup>

<sup>a</sup> *Department of Pharmacy-Pharmaceutical Sciences, University of Bari Aldo Moro, Campus E. Quagliariello, via E. Orabona, 4, 70126-Bari, Italy*

<sup>b</sup> *Institute of Science of Food Production (ISPA), Research National Council (CNR), via Amendola, 122/O, 70126-Bari, Italy*

<sup>c</sup> *Department of Precision and Regenerative Medicine and Jonian Area (DiMePRe-J), Section of Veterinary Science and Animal production, University of Bari Aldo Moro, 70010-Valenzano, Bari, Italy*

E-mail: [vincenzo.roselli@uniba.it](mailto:vincenzo.roselli@uniba.it)

As a consequence of the constant population growing, agro-industrial wastes are gradually becoming one of major causes of the global environmental pollution [1]. Therefore, it is important to find a strategy focused on reusing these by-products, valorizing their potential as a sustainable source of bioactive molecules with health benefits, in order to provide innovative feed and food supplements [1].

In this context, two cultivars of grape pomaces (Cabernet Sauvignon and Petit Verdot) have been selected as starting secondary raw materials to perform preliminary extractions using, as liquid green extracting phases, the so-called Deep Eutectic Solvents (DESs) and hydroalcoholic solutions as reference. The extracts obtained from both fresh and dried matrices were, then, chemically characterized for their phenolic compounds profile through HPLC-DAD. All thirty-six samples analysed contained eight out to thirteen phenolic compounds taken as standards (gallic acid, coumaric acid, syringic acid, caffeic acid, catechin, rutin, quercetin and kaempferol galactoside) with a maximum concentration detected in a single sample of 0.492 µg/g (quercetin).

Preliminary DPPH radical photometric assays showed a significant antioxidant activity of the extracts, up to 14935 µM Gallic Acid Equivalents for the sample obtained from dried Petit Verdot pomace using the DES Choline Chloride/Urea (1:2) +40% water as solvent. Molecular biology studies will follow to find a possible correlation between the already proven nutraceutical value of the extracts and variation on selected gene expression.

V.R. fellowship was funded by Unione Europea -Next Generation EU. M.U.R., D.M. 02/03/2023, N. 118. Titolo Progetto: Soluzioni sostenibili per la produzione di nuovi integratori ottenuti a partire da scarti dell'industria alimentare.

[1] V. Roselli, G. Pugliese, R. Leuci, L. Brunetti, L. Gambacorta, V. Tufarelli, L. Piemontese, *Molecules* 29 (2024) 2682

## Batch and continuous-flow photoinduced oxidative cleavage of unsaturated fatty acids

Sara Stocchetti, Alberto Luridiana, and Francesco Secci

*Dipartimento di Scienze Chimiche e Geologiche, Università degli Studi di Cagliari, Str. interna Policlinico Universitario, 09042 Monserrato CA*  
E-mail: [sara.stocchetti@unica.it](mailto:sara.stocchetti@unica.it)

The oxidative cleavage of the C=C double bond provides a direct route for obtaining valuable oxygenated compounds. While ozonolysis has been the oldest and the predominant method for oxidizing alkenes, concerns over ozone's toxicity have driven the development of alternative approaches, including chemical, enzymatic, and photochemical processes.

Building on principles from photo-induced transformations and the reactivity of alkenes [1], this project focuses on promoting the aerobic photo-oxidative double bond cleavage of aliphatic long-chain fatty acids. Oleic acid, a prevalent component of plant-derived oils, serves as the benchmark in this preliminary study. The purpose is to produce important compounds such as pelargonic acid and azelaic acid, which are utilized across various industrial sectors [2]. Firstly, the process was investigated in batch mode using a 3D printed reactor [3], providing mechanistic insights into the process. Following this, a screening study was conducted to evaluate a range of organic photocatalysts, with a particular focus on organic dyes as sustainable alternatives to traditional metal-based catalysts. This selection process aimed to identify photocatalysts that could offer both environmental benefits and high efficiency. This preliminary phase was crucial for understanding the reaction's behaviour and establishing the key parameters of the overall system. Exploiting this, the next phase will involve continuous flow technology. This approach is expected to achieve intensified reaction conditions, reducing catalyst loading and reaction time. Continuous flow technology will not only improve the efficiency of the process but also facilitate scalability, making it more suitable for large-scale applications.

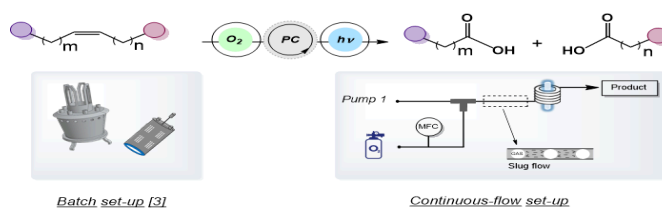

**Figure 1:** Batch and flow set-up in the oxidative cleavage of unsaturated fatty acids.

[1] W. A. Hussain and M. Parasram, *Synth.* (56), 2024, 1775-1786.

[2] A. Soutelo-Maria, J.-L. Dubois, J.-L. Couturier and G. Cravotto, *Catalysis* (8), 2018, 464.

[3] T. M. Masson, S. D. A. Zondag, J. H. A. Schuurmans and T. Noël, *React. Chem. Eng.* 2024, Adv. Art.

## SERS sensors for the therapeutic drug monitoring of anticancer agents

Ludovica Russo,<sup>a,b</sup> Pellegrino Musto,<sup>b</sup> and Marianna Pannico<sup>b</sup>

<sup>a</sup> Department of Chemical, Material and Industrial Production Engineering, University of Naples Federico II, Piazzale Vincenzo Tecchio 80, 80125 – Naples (NA), Italy

<sup>b</sup> Institute for Polymers, Composites and Biomaterials, National Research Council of Italy, Via Campi Flegrei 34, 80078 - Pozzuoli (NA), Italy  
E-mail: ludovica.russo3@unina.it

Therapeutic drug monitoring (TDM) involves measuring specific drugs in biofluids at intervals to maintain controlled concentrations in a patient's bloodstream, optimizing dosage regimens. While TDM has been effective for anticancer therapies, it is rarely used in practice due to cost, time, and the lack of point-of-care tools. Alternative, cost-effective analytical approaches to TDM are needed.

To address this, we developed two Surface Enhanced Raman Spectroscopy (SERS) platforms: a colloidal gold nanoparticle (AuNP) solution and a 2D sensor with AuNPs on functionalized gold-coated glass. These platforms were tested using a SERS-active probe, p-mercaptoaniline (pMA), showing Enhancement Factors of  $5.4 \times 10^5$  and  $2.60 \times 10^8$  for the colloid and 2D substrate, respectively. Both sensors effectively detected and quantified the chemotherapeutic agent 6-mercaptopurine (6-MP) [1,2].

Time-resolved SERS experiments on AuNPs revealed high linearity for quantitative analysis of 6-MP between 5 and 20  $\mu\text{M}$ , with a detection limit of 1.0  $\mu\text{M}$  [1]. The 2D sensor exhibited strong SERS activity and stable nanoparticle distribution, maintaining a linear correlation between analyte concentration and SERS intensity within the 5-20  $\mu\text{M}$  range of 6-MP [2].

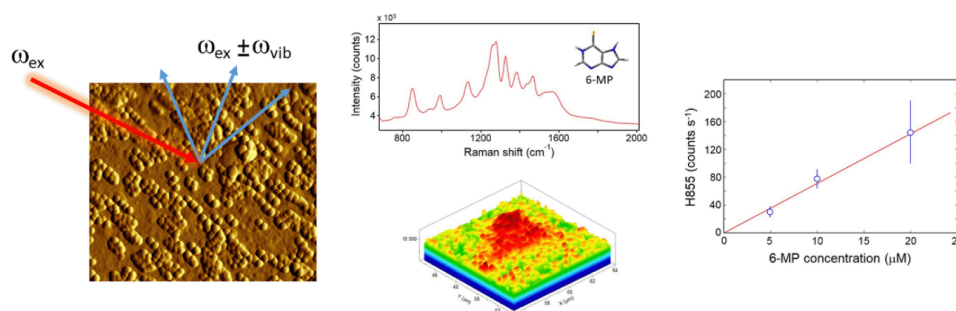

**Figure 1:** AFM image of 2D platform; SERS spectrum of 6-MP; AFM/Raman map of 6-MP; calibration curve for the quantitative analysis of 6-MP.

[1] M. Pannico, and P. Musto, *Appl. Surf. Sci.* 539 (2021) 1448225

[2] M. Pannico, and P. Musto, *Spectrochim. Acta A Mol. Biomol. Spectrosc.* 311 (2024) 123983

## Mesoionic carbenes as a powerful tool for conjugating biologically relevant molecules on palladium complexes for cancer therapy

Giovanni Tonon,<sup>a</sup> Thomas Scattolin,<sup>b</sup> and Fabiano Visentin<sup>a</sup>

<sup>a</sup> Department of Molecular Sciences and Nanosystems, Università Ca' Foscari Venezia, Campus Scientifico Via Torino 155, 30174, Venezia-Mestre, Italy

<sup>b</sup> Department of Chemical Sciences, Università degli Studi di Padova, 35131 Padova, Italy  
E-mail: [giovanni.tonon@unive.it](mailto:giovanni.tonon@unive.it)

The development of anticancer drugs that target specifically tumor sites is of outmost importance in cancer chemotherapy and this research line is currently in significative expansion. Cancer tissues require larger amounts of glucose than non-cancerous ones, having high rates of aerobic glycolysis. This is known as Warburg effect, and it is recognized as a hallmark of cancer [1]. The conjugation of biomolecules as monosaccharides to drugs could improve their selectivity towards cancer cells exploiting the effect of specific enzymes overexpressed in cancer tissues, which then release the cytotoxic payload on the tumor site. The activity of glycosidases (e.g.  $\alpha$ -mannosidase), enzymes that catalyze the hydrolysis of glycosidic bonds in complex sugars, are elevated in some type of cancers [2]. In addition, it is well-known that glucose transporter 1, a protein involved in the transport of glucose through plasma membranes, is overexpressed in a high percentage of cancers [1].

Bio-conjugated 1,2,3-triazol-5-ylidene precursors can be easily synthesized making use of the Copper(I)-catalyzed Azide-Alkyne Cycloaddition (CuAAC). Based on the promising recent results on cancer therapy obtained with organopalladium compounds [3], and the small number of works dealing with Pd-mesoionic carbene (MIC) complexes, we report in this contribution the synthesis of some novel organopalladium complexes conjugated to different monosaccharides (mannose and glucose) through a 1,2,3-triazol-5-ylidene moiety (Figure 1). All complexes were obtained by reacting the triazolium salt with a palladium precursor, adopting the “weak base route”. This reaction, whose mechanism consists in a concerted deprotonation/metalation of the triazolium salt, proceeds under mild conditions using inexpensive and mild bases such as  $K_2CO_3$ . To the best of our knowledge, this is the first extension of this type of process to the synthesis of palladium MIC complexes. Moreover, we had been able to isolate also the allyl palladate intermediates.

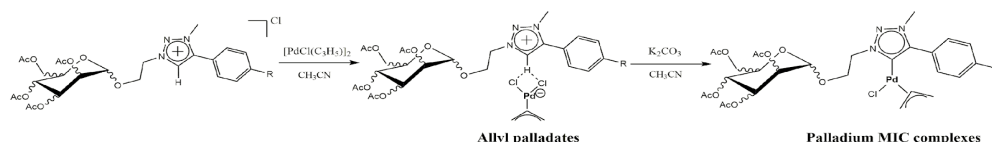

**Figure 1:** Synthesis of palladium MIC complexes and allyl palladate intermediates.

[1] P. Mathew, A. Neels, and M. Albrecht, *J. Am. Chem. Soc.* 130 (2008) 13534-13535.

[2] S. S. Yuan, J. S. Chen, L. Zhou, and W. Zhou, *Chem. Med. Chem.* 13 (2018) 764-778.

[3] T. Scattolin, V. A. Voloshkin, F. Visentin and S. P. Nolan, *Cell Rep. Phys. Sci.* 2 (2021) 100446.

## New potent and selective dopamine D<sub>4</sub> receptor ligands potentially useful to treat glioblastoma

Federica Matteucci,<sup>a</sup> Fabio Del Bello,<sup>a</sup> Gianfabio Giorgioni,<sup>a</sup> Alessandro Piergentili,<sup>a</sup> Wilma Quaglia,<sup>a</sup> Loredana Cappellacci,<sup>a</sup> and Riccardo Petrelli<sup>a</sup>

<sup>a</sup> School of Pharmacy, Chemistry Interdisciplinary Project (ChIP), University of Camerino, via Madonna delle Carceri, 62032 Camerino (MC), Italy  
E-mail: [federica.matteucci@unicam.it](mailto:federica.matteucci@unicam.it)

Since its identification and cloning in early 1990s, the dopamine D<sub>4</sub> receptor (D<sub>4</sub>R) has been proposed as a valuable target for the treatment of neuropsychiatric disorders. However, attempts to clinically use D<sub>4</sub>R antagonists as antipsychotic medications proved unsuccessful, making researchers lose their interest in D<sub>4</sub>R as a therapeutic target, and work in this area was silent for years [1]. Novel findings have renewed the interest for this receptor as an emerging target for the management of diseases different from psychosis, including brain cancers. Indeed, D<sub>4</sub>R inhibition has proved to disrupt the autophagy-lysosomal pathway of glioblastoma neural stem cells, leading to apoptosis. Furthermore, according to the Cancer Genome Atlas data on glioblastoma gene expression, adult patients with high D<sub>4</sub>R levels have worse survival than those with low expression [2].

Herein, our recent advances on the development of subtype selective D<sub>4</sub>R ligands and their potential involvement in the treatment of glioblastoma will be presented. The potent and selective D<sub>4</sub>R ligand **1**, highly soluble at pH 7.4 and able to cross the blood-brain barrier [3], has been used as a lead compound for the discovery of new selective ligands with nanomolar D<sub>4</sub>R affinity. Specifically, substituents with different electronic and lipophilic contributions were inserted in ortho, meta and para positions of the *N*-phenyl terminal. Moreover, the aromatic area of **1** has been extended by inserting an additional phenyl ring or by replacing the phenyl terminal with an  $\alpha$ - and  $\beta$ -naphthyl group (Figure 1).

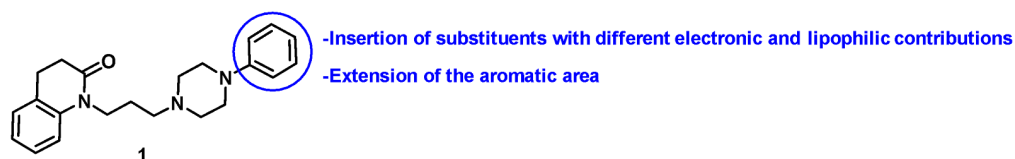

**Figure 1:** Designed modifications on the *N*-phenyl terminal of the potent D<sub>4</sub>R ligand **1**.

All the compounds were evaluated for their affinity at D<sub>2</sub>R, D<sub>3</sub>R and D<sub>4</sub>R by radioligand binding assays, and the most selective D<sub>4</sub>R ligands were evaluated for their potential in affecting the viability of glioblastoma cell lines.

[1] G. Giorgioni, F. Del Bello, P. Pavletic, W. Quaglia, L. Botticelli, C. Cifani, E. Micioni Di Bonaventura, M.V. Micioni Di Bonaventura, and A. Piergentili, *Eur. J. Med. Chem.* 212 (2021) 113141

[2] S. Dolma, H.J. Selvadurai, X. Lan, L. Lee, M. Kushida, V. Voisin, H. Whetstone, M. So, T. Aviv, N. Park, X. Zhu, C. Xu, R. Head, K.J. Rowland, M. Bernstein, I.D. Clarke, G. Bader, L. Harrington, J.H. Brumell, M. Tyers, P.B. Dirks, *Cancer Cell.* 29 (2016) 859-873

[3] F. Del Bello, A. Bonifazi, G. Giorgioni, C. Cifani, M.V. Micioni Di Bonaventura, R. Petrelli, A. Piergentili, S. Fontana, V. Mammoli, H. Yano, R. Matucci, G. Vistoli, and W. Quaglia *J. Med. Chem.* 61 (2018) 3712-3725

## Novel cyclodextrin-based delivery systems as promising tools for RNA gene therapy: a proof of concept

Giovanni Petrarolo,<sup>a</sup> Ilaria D'Agostino,<sup>a</sup> Lorenzo Arrico,<sup>b</sup> Lorenzo Germelli,<sup>a</sup> Laura Marchetti,<sup>a</sup> Lorenzo Di Bari,<sup>b</sup> Claudia Martini,<sup>a</sup> and Concettina La Motta<sup>a</sup>

<sup>a</sup> *Dipartimento di Farmacia, University of Pisa, Via Bonanno 6, 56126-Pisa, Italy*

<sup>b</sup> *Dipartimento di Chimica e Chimica industriale, University of Pisa, Via Moruzzi 13, 56124 -Pisa, Italy*  
Email: [giovanni.petrarolo@farm.unipi.it](mailto:giovanni.petrarolo@farm.unipi.it)

Gene therapy is an emerging strategy in clinics, particularly relevant in treating cancer, diabetes, and orphan diseases, being able to correct defective genes or gene products with a long-term outcome.[1] However, specific delivery systems are required for the administration of therapeutic nucleic acids since they are not able to enter the cell, being hydrophilic and possessing a large size, and are highly susceptible to degradation by nucleases. In this context, non-viral carriers, such as  $\beta$ -Cyclodextrins (CDs), have recently emerged for biocompatibility and versatility. Moreover, their simple structure allows chemical modification and generation of more complex architecture, such as polymers and nanosponges.[2,3]

Aimed at delivering specific therapeutic miRNAs, we developed an innovative system based on a first-generation  $\beta$ -CD nanosponge (NS) made up of CDs crosslinked through a carbonate moiety and a bridge-like molecule (BLM). The latter is an adamantyl derivative endowed with a cationic head and a suitable spacer. Thanks to its chemical features, BLM is able to establish strong interactions with both NS and miRNAs. In particular, the adamantyl cage links the CD cavity and NS pores via host-guest inclusion and van der Waals contacts whereas the cationic head forms electrostatic and polar interactions with the negative charge of miRNA phosphate groups. The supermolecular NS-BLM complex was deeply investigated through FTIR and NMR analyses, including ROESY and DOSY experiments. Also, the systems were found non-toxic on HEK-293 cell line, as assessed by MTS assay, showing a safe profile at the highest tested concentration (1 mg/mL).

[1] J. A. Kulkarni, D. Witzigmann, S. B. Thomson, S. Chen, B. R. Leavitt, P. R. Cullis and R. van der Meel. *Nature Nanotechnology* (2021), 16, 630–643

[2] N. Sayed, P. Allawadhi, A. Khurana, V. Singh, U. Navik, S. Kumar Pasumarthi, I. Khurana, A. Kumar Banothu, R. Weiskirchen, K. K. Bharan. *Life sciences* 294 (2022): 120375.

[3] V. Coviello, S. Sartini, L. Quattrini, C. Baraldi, M. C. Gamberini and C. La Motta. *European Journal of Pharmaceutics and Biopharmaceutics* (2017), 117, 276-285.

---

## POS014

### Potential REXO2 inhibitors: synthesis and biological evaluation of triazole-linked dimers

Alessia Piergentili,<sup>a</sup> Eleonora Spinozzi,<sup>a</sup> Riccardo Petrelli,<sup>a</sup> Marta Ferrati,<sup>a</sup> Diego Romano Perinelli,<sup>a</sup> Giulia Bonacucina,<sup>a</sup> Marzia Arese,<sup>b</sup> Serena Rinaldo,<sup>b</sup> and Loredana Cappellacci<sup>a</sup>

<sup>a</sup> Chemistry Interdisciplinary Project (ChIP) Research Center, University of Camerino, via Madonna delle Carceri, 62032-Camerino, Italy

<sup>b</sup> Department of Biochemical Sciences "A. Rossi Fanelli", Sapienza University of Rome, P.le A. Moro 5, 00185-Rome, Italy

E-mail: [alessia.piergentili@unicam.it](mailto:alessia.piergentili@unicam.it)

Cancer is the second leading cause of death worldwide. Currently, it has become clear that mitochondrial function is essential for the viability of cancer cells. In this contest, mitochondrial ribonucleases are essential to ensure mitochondrial RNA (mtRNA) maturation, being the mitochondrial DNA transcribed as polycistronic constructs, and degradation. Irregular mtRNA processing and decay is linked to pathological conditions such as chronic inflammation and ageing [1]. mtRNA processing generates numerous non-coding RNAs which require prompt degradation. Altered degradosome turnover leads to accumulation of anti-sense mtRNA, affecting protein expression, and double-stranded RNA, which may activate interferon response. Downstream the degradosome, the remnant fragments are degraded as single monophosphate nucleotides by REXO2, an exoribonuclease mainly working in mitochondria. It has recently been demonstrated that REXO2 is overexpressed in several cancers or cancer risk assets [2], in line with previous evidence showing aberrantly expression of RNA binding proteins in several malignant tumors. REXO2 can catalyze the hydrolysis of 2-5 nucleotides nanoRNA (and also DNA), with the highest affinity (nM) for the 2 nucleotide substrates [3]. Given its relevance in sustaining proliferation, REXO2 represents a promising target for the discovery of novel mitochondrial targeted anticancer-drugs (mitocans). The goal of this work was to design purine-based dimers able to specifically inhibit REXO2, with the aim to interfere with cell proliferation. Specifically, these compounds have been designed by removal of the sugar moiety and bioisosterically replacement of the charged and hydrolysable phosphodiester group of dinucleotide substrates with the neutral and stable 1,2,3-triazole ring linked to the bases by linkers of variable length.

In this work, different triazole-linked dimers have been synthesized and preliminary enzymatic assay has been done. The results of the enzymatic assay showed that DCI061 could be a promising lead compound. Further structure-activity relationships studies are ongoing.

*Acknowledgments: PRIN 2022, funded by the European Union – NextGenerationEU – Project N. 2022KC3X9L CUP N. J53D23009040006*

[1] J. Rorbach, and M. Minczuk. *Biochem. J.* 444.3 (2012) 357-373

[2] I. Hular, E. R. Gamazon, A. D. Skol, R. M. Xicola, X. Llor, K. Onel, N. A. Ellis, and S. S. Kupfer. *BMC Genet.* 16 (2015) 1-15

[3] L. Chu, S. Agrawal, Y. Chen, W. Yang, and H. Yuan. *RNA* 25.6 (2019) 737-746

## In silico studies for the design of new tyrosinase inhibitors as component for skincare products

Giovanna Pitasi,<sup>a</sup> Salvatore Mirabile,<sup>a</sup> Kristina Schira,<sup>b</sup> Jörg Scheuermann,<sup>b</sup> Maria Paola Germanò,<sup>a</sup> Rosaria Gitto,<sup>a</sup> and Laura De Luca<sup>a</sup>

<sup>a</sup> Chibiofaram Department, University of Messina, Viale Ferdinando Stagno d'Alcontres, 31 98166, Messina, Italy

<sup>b</sup> Department of Chemistry and Applied Biosciences, Institute of Pharmaceutical Sciences, ETH Zürich, 8093 Zürich, Switzerland

E-mail: [giovanna.pitasi@studenti.unime.it](mailto:giovanna.pitasi@studenti.unime.it)

Tyrosinase (TYR, EC 1.14.18.1) belongs to the oxidase superfamily; it is known to be a multifunctional enzyme containing copper ions, which are coordinated by six conserved histidine residues [1]. TYR is a key protein involved in melanin biosynthesis playing an important role in human skin. The excessive production of melanin can cause hyperpigmentation disorders such as freckles, melasma and blemishes [2]. Many efforts are made to discover novel, potent, tyrosinase inhibitors for the development of therapeutics for these skin disorders. Among them  $\beta$ -arbutin, and kojic acid are approved for cosmetic applications but have recently been shown to have serious adverse effects [2].

In recent years, several classes of natural and synthetic compounds have been identified using TYR from *Agaricus bisporus* (AbTYR) as an inexpensive surrogate of human isozyme (hTYR). In order to further improve our knowledge and study their binding site interactions of tyrosinase inhibitors, we focused our interest on a series of compounds structurally related to the [4-(4-hydroxyphenyl)piperazin-1-yl](2-methoxyphenyl)methanone, that we have recently developed as AbTYR and hTYR inhibitor [3].

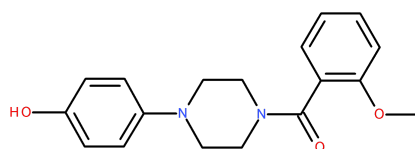

**Figure 1:** Structure of the compound Meht-3

In this work we will report the experimental data of different compounds that will be studied using computational techniques. Docking and molecular dynamics studies will be carried out on the 3D crystal structure of AbTYR (RCSB PDB:2y9x) and our homology model of hTYR.

This work was supported by Italian Ministry of Education, University and Research: (project PRIN 201744BN5). The authors thank the “I.3.3 Borse PNRR-Dottorati innovativi che rispondono ai fabbisogni di innovazione delle imprese”, XXXVIII cycle, for financial support in form of a PhD scholarship “DOT1314952” granted to Giovanna Pitasi.

[1] Vittorio S, Dank C, Ielo L. *Int J Mol Sci* (2023); 9097.

[2] Thawabteh AM, Jibreen A, Karaman D, Thawabteh A, Karaman R, *Molecules* 28 (2023) 4839.

[3] Ricci F, Schira K, Khettabi L, Lombardo L, Mirabile S, Gitto R, Soler-Lopez M, Scheuermann J, Wolber G, De Luca L. *Eur J Med Chem.* (2023); 115771.

## Study of plasticizer migration from PVC by confocal Raman spectroscopy

Marica Gallo,<sup>a,b</sup> Pellegrino Musto,<sup>b</sup> and Marianna Pannico<sup>b</sup>

<sup>a</sup> National Research Council of Italy, Institute for Polymers, Composites and Biomaterials, via Campi Flegrei, 34, 80078, Pozzuoli, Naples, Italy

<sup>b</sup> DICMaPI, Department of Chemical, Materials and Industrial Production Engineering, University of Naples Federico II, Piazzale Tecchio, 80, 80125, Naples, Italy.  
E-mail: marica.gallo2unina.it

Poly(vinyl chloride) (PVC) is a widely used synthetic polymer known for its cost-effectiveness, high mechanical properties, and versatility. The incorporation of additives, particularly plasticizers, enhances its processability, flexibility, and low-temperature performance, significantly impacting its properties and applications. However, in several applications, the migration of plasticizers, such as di(2-ethylhexyl) phthalate (DEHP) poses environmental and health risks due to DEHP's toxicity [1].

This study focuses on the migration of plasticizers in PVC matrices, employing confocal Raman microspectroscopy (CRM) as a novel technique to monitor this process [2]. The CRM analytical approach was validated by studying different flexible PVC formulations: PVC with DEHP (pPVC@DEHP), PVC with poly(butylene adipate) (pPVC@PBA), and crosslinked flexible PVC (cPVC@DEHP), using isophorone diamine (IPDA) as a crosslinker. Plasticizer migration was evaluated over time by performing depth profile measurements (z-scan) in mapping mode on rigid PVC samples (rPVC) simulating coextruded flexible/rigid PVC pipes. The study demonstrated a linear correlation between CRM data and traditional gravimetric methods confirming the distinct diffusion behaviors of different formulations. Additionally, CRM provides spatially resolved chemical information, allowing simultaneous monitoring of both plasticizer concentration and distribution.

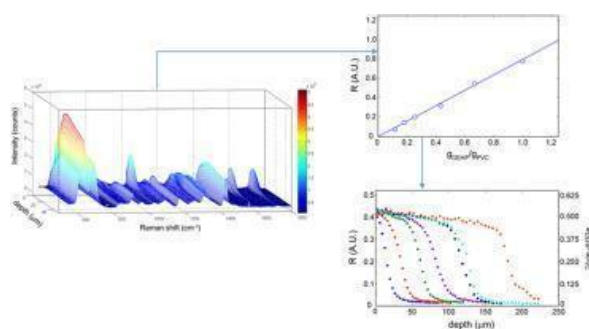

**Figure 1:** Migration results after 2 days: Raman spectra of rPVC film in contact with pPVC@DEHP; DEHP calibration curve; CRM profiles for DEHP migration from pPVC@DEHP.

[1] J.-L. Audic, D. Reyx, and J.-C. Brosse, *J. Appl. Polym. Sci.*, 89 (2003), pp. 1291-1299

[2] M. Pannico, and P. Musto, *Polymer*, Volume 294, (2024), 126731

## Cobalt(III) complexes as structure-directing agents in the synthesis for zeolites

Janina Carolin Höner,<sup>a</sup> Andreas Schaate<sup>a</sup> and Yaşar Krysiak<sup>a</sup>

<sup>a</sup>*Institute of Inorganic Chemistry, Leibniz University Hannover, Callinstrasse 9, 30167 Hannover, Germany  
E-mail: [j.hoener@jcf.io](mailto:j.hoener@jcf.io)*

Zeolites have a wide range of applications i.e. as molecular sieve or catalysts for organic reactions. In order to design the properties of these materials, the pore size and form plays a decisive role. Structure-directing agents (SDAs) are used to control the formation. These are typically organic amines or alkylammonium salts, but it is also possible to use metal complexes.

The use of metal complexes as SDA offers an excellent possibility to incorporate metal atoms into the silica framework during the removal of the SDA by the calcination process. The contained metal atom can be used as catalytic active center in organic reaction [1-2].

Using metal complexes brings a lot of challenges. Beside the thermal stability, the stability in solution in dependency on the pH value plays an important role during the hydrothermal synthesis of the zeolite. An alkaline solution, as it is used in zeolite synthesis, of the metal complex at higher temperatures mostly leads to a decrease in the stability of the metal complex resulting in an amorphous silicon product. Lower pH value or lower temperature could ensure that a crystalline product is formed but the ranges for this formation are extremely small.

Octahedral cobalt complexes (Figure 1) based on the cobalt(III) ethylenediamine complex, so called WERNER complexes [1], are deployed as the SDAs in different synthesis routes for zeolite synthesis. The complexes can be used as SDA or as co-SDA in combination with published SDAs for known zeolite structure i.e. tetramethyl amine hydroxide in the formation of zeolite A (LTA). Another way is to incapsulate the complex in the pore system of a zeolite framework. Further recrystallize yields to another zeolite structure.

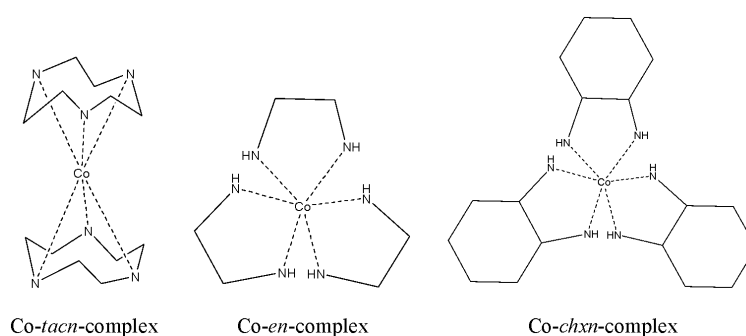

**Figure 1:** Schematic presentation of used cobalt(III)-complexes.

[1] H. Xu, J. Zhang, Q. Wu, W. Chen, C. Lei, Q. Zhu, S. Han, J. Fei, A. Zheng, L. Zhu, X. Meng, S. Maurer, D. Dai, A.N. Parvulescu, U. Müller, and F.S. Xiao, *ACS Appl. Mater. Interfaces* 10 (2018) 33214.

[2] L. Ren, L. Zhu, C. Yang, Y. Chen, Qi Sun, H. Zhang, C. Li, F. Nawaz, X. Meng and F.S. Xiao, *Chem. Commun.* 47 (2011) 9789.

## Tailored immobilization of LPMOs on functionalized Carbon Nanotubes: insights into spacer effects and enzyme stability

Fabrizio Careddu<sup>ac</sup>, Carlotta Pontremoli<sup>a</sup>, Kelsi R. Hall<sup>b</sup>, Vincent G.H. Eijsink<sup>b</sup>, Claudia Barolo<sup>a</sup>, Silvia Bordiga<sup>a</sup>, Morten Sørli<sup>b</sup>, Matteo Bonomo<sup>a</sup> and Tom Z. Emrich Mills<sup>b</sup>

<sup>a</sup>Department of Chemistry, NIS Interdepartmental and INSTM Reference Centre, University of Torino, Torino, Italy

<sup>b</sup>Faculty of Chemistry, Biotechnology and Food Science, NMBU-Norwegian University of Life Sciences, Ås, Norway

<sup>c</sup> University School for Advanced Studies IUSS Pavia, Palazzo del Broletto, Piazza della Vittoria 15 I-27000, Pavia, Italy

E-mail: [fabrizio.careddu@unito.it](mailto:fabrizio.careddu@unito.it)

Lytic polysaccharide monooxygenases (LPMOs) are copper-containing mononuclear enzymes found in most cellulolytic fungi and actinomycete bacteria, capable of oxidizing the C-H bond of glycosidic linkages in various polysaccharide substrates[1]. However, oxidative damage (particularly in the absence of substrate) and stability remain significant obstacles to their industrial application as potential biocatalysts for C-H bond oxidation. Therefore, the immobilization of the enzyme on a suitable support is being explored, being a possible method for preserving the catalytic activity of LPMOs, increase their resistance to oxidative stress, and enable the reuse of the catalyst in subsequent cycles.

This contribution addresses the immobilization of two different LPMOs, ScAA10C from *Streptomyces coelicolor* and LsAA9A from *Lentinus similis*, previously engineered to facilitate immobilization, through exposed lysine residues, on a support of carboxy-functionalized multi-walled carbon nanotubes (COOH-MWCNTs), leveraging N-(3-dimethylaminopropyl)-N'-ethylcarbodiimide hydrochloride (EDC) and N-hydroxysuccinimide (NHS) to activate the support and promote targeted immobilization. The chosen method was effective in facilitating enzyme immobilization and was adapted to incorporate spacers of different lengths (i.e., glycine, GABA, and  $\alpha$ -amino- $\omega$ -propionic acid diethylene glycol) to evaluate the contribution of enzyme/support steric hindrance on the catalytic performance of the new bio-catalyst. The performance of the new systems was evaluated by measuring oxidase and peroxidase activities of the immobilized enzymes using an Amplex Red and a 2,6-DMP assays[2,3], respectively, while the peroxygenase activity was determined using soluble cellopentaose and insoluble PASC as substrates in time-course catalytic tests. The resistance to temperature and various solvents was examined via circular dichroism. The immobilization approach successfully enhanced the enzyme's resistance to oxidative stress, and the incorporation of different spacers provided insights into the effect of steric hindrance on catalytic performance, paving the way for further optimization of LPMOs as industrial biocatalysts.

[1] Vaaje-Kolstad, Gustav, et al. "An oxidative enzyme boosting the enzymatic conversion of recalcitrant polysaccharides." *Science* 330.6001 (2010): 219-222.

[2] Kittl, Roman, et al. "Production of four *Neurospora crassa* lytic polysaccharide monooxygenases in *Pichia pastoris* monitored by a fluorimetric assay." *Biotechnology for biofuels* 5 (2012): 1-14.

---

## POS019

### On the effects of punctual defects on the electronic structure of lead halide perovskites

Carmen Serpico<sup>a,b</sup>, Lucia Vittoria Mercaldo<sup>b</sup>, Gennaro Vincenzo Sannino<sup>a,b</sup>, Manuela Ferrara<sup>b</sup>, Federica Maria Caso<sup>b</sup>, Paola Delli Veneri<sup>b</sup>, Adriana Pecoraro<sup>c</sup>, Ana B. Muñoz García<sup>c</sup>, Michele Pavone<sup>a</sup>

<sup>a</sup> Department of Chemical Sciences, University of Naples Federico II, Comp. Univ. Monte Sant'Angelo, Via Cinthia, 26, 80126, Naples, Italy.

<sup>b</sup> Italian National Agency for New Technologies, Energy and Sustainable Economic Development (ENEA) – Portici, Research Centre, Piazzale E. Fermi 1, 80055 Portici, NA, Italy.

<sup>c</sup> Department of Physics “Ettore Pancini”, University of Naples Federico II, Comp. Univ. Monte Sant'Angelo, Via Cintia 21, 80126, Naples, Italy.  
Email: [carmen.serpico@unina.it](mailto:carmen.serpico@unina.it)

Lead halide perovskites (LHPs) attracted great interest as light harvesters thanks to their optoelectronic properties [1]: the first and most studied lead halide for perovskite solar cells (PSCs) is the methylammonium lead triiodide (MAPI). Since LHPs are typically used as a light absorber in most applications, their electronic and optical properties are of primary importance. In this regard, we studied this photoabsorber combining two approaches: one based on theoretical calculations for the determination of electronic properties and the other experimental one, for the material optimization and device's fabrication. At first, tetragonal MAPI perovskite films have been characterized through XRD, SEM, EDX and Uv-Vis spectroscopy and once the optimal conditions of these films are reached, devices have been fabricated in the n-i-p architecture from single precursors by the two-step hybrid evaporation/spin-coating method. For device fabrication, the substrates are subjected to UV/ozone treatment to improve surface wettability and the various layers are deposited on glass and ITO in sequence: electron transport layer (ETL) SnO<sub>2</sub>, perovskite absorber, hole transport layer (HTL) Spiro-OMeTAD and Au as cathode.

From the computational perspective, the effect of Pb/MAI/MAI vacancies on the electronic structure of the MAPI tetragonal phase (space group: I4/mcm) has been evaluated with state-of-the-art density functional theory (DFT) calculations [2]. Analysis of the projected density of states (pDOS) of defective materials in comparison with the pristine material show that the most likely vacancies, i.e. iodine and lead, induce n-type and p-type doping, respectively, and generate both shallow defect levels near the corresponding band gap edges or inside the bandgap. In conclusion, these results will pave the route to the rational design of MAPI-based PSCs by establishing relationships between the synthesis methods, defectivity and ensuing electronic properties.

[1] Kosasih et al., *Joule* 6 (2022) 6 1-43.

[2] K. Burke, *J. Chem. Phys.* 136 (2012) 150901.

## Development of Colorless Cobalt Complexes for high transparent Dye-Sensitized Solar Cells.

Y. Nowak,<sup>a</sup> M. Calamante,<sup>a,b</sup> A. Dessì,<sup>a</sup> D. Franchi,<sup>a</sup> G. Reginato,<sup>a</sup> L. Zani,<sup>a</sup> A. Mordini<sup>a,b</sup>

<sup>a</sup> CNR-Institute of Chemistry of Organometallic Compounds, Sesto Fiorentino, Italy

<sup>b</sup> Department of Chemistry "Ugo Schiff", University of Florence, Sesto Fiorentino, Italy

e-mail: [ylenia.nowak@iccom.cnr.it](mailto:ylenia.nowak@iccom.cnr.it)

The advancement of photovoltaic (PV) technology is critical for sustainable energy production, with silicon-based solar cells being the most prevalent due to their efficiency and cost-effectiveness. However, integrating photovoltaic panels into homes and buildings can be challenging due to the black or dark blue coloration of silicon-based photovoltaic devices. To address this issue, some research groups are focusing on the development of alternative systems, such as dye-sensitized solar cells (DSSCs). DSSCs typically consist of a photoanode made of titanium dioxide (TiO<sub>2</sub>) coated with a light-sensitive dye. When sunlight strikes the dye, a photoexcitation process occurs, causing electrons to be injected into the conduction band (CB) of the TiO<sub>2</sub>, which then flow through an external circuit to generate an electric current. The oxidized dye molecules are regenerated by a redox mediator in the electrolyte, usually iodide/triiodide, which transfers electrons back to the dye. For better integration of DSSCs into buildings, the use of colorless materials is essential. For this reason, dyes that absorb in the near-infrared and redox mediators that are transparent to visible light are being studied. We present here new pyridinyl benzo[d]imidazole ligands designed to coordinate metals, particularly the cobalt ion, forming colorless octahedral metal complexes. These ligands were synthesized and characterized, then used to prepare cobalt complexes. These compounds serve as substitutes for the common redox mediators, such as the iodide/triiodide system mentioned earlier.

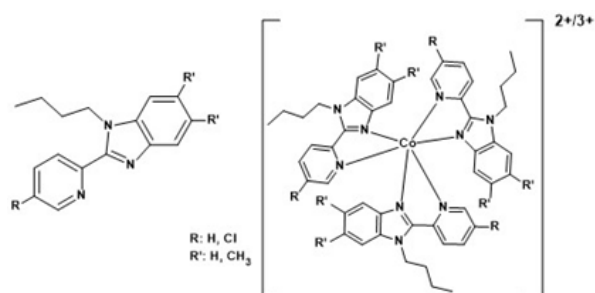

**Acknowledgment:** We thank the Ministry of Environment and Energy Security (POR H<sub>2</sub>, A.d.P. MASE/ENEA-CNR-RSE, CUP B93C22000630006 and "IEMAP" project, A.d.P. MASE/ENEA-CNR-IIT-RSE, CUP B82C21001820001) and project "nuovi Concetti, mAteriali e tecnologie per l'iNtegrazione del fotoVoltAico negli edifici in uno scenario di generazione diffuSa" ("CANVAS"), funded by the Italian Ministry of the Environment and the Energy Security, through the Research Fund for the Italian Electrical System (type-A call, published on G.U.R.I. n. 192 on 18-08-2022) for funding.

## First-principles investigation of P2- $\text{Na}_x\text{Ni}_{0.25}\text{Mn}_{0.75}\text{O}_2$ / PyrFSI electrode/electrolyte interfaces for Na-ion batteries

Andrea Grillo,<sup>a,b</sup> Arianna Massaro,<sup>a,b</sup> Ana Belén Muñoz-García,<sup>c,b</sup> and Michele Pavone<sup>a,b</sup>

<sup>a</sup> Department of Chemical Sciences, University of Naples Federico II, Via Cintia 26, 80126 Naples, Italy

<sup>b</sup> Consorzio Interuniversitario Nazionale per la Scienza e Tecnologia dei Materiali (INSTM), Via Giuseppe Giusti 9, 50121 Florence, Italy

<sup>c</sup> Department of Physics "Ettore Pancini", University of Naples Federico II, Via Cintia 26, 80126 Naples, Italy  
e-mail: [andrea.grillo@unina.it](mailto:andrea.grillo@unina.it)

Na-ion batteries (NIBs) are at the forefront of energy storage technology due to larger abundance of raw materials and enhanced cost-effectiveness compared to Li-ion counterparts [1]. Despite the great advances achieved in last decades, identification of efficient and stable component materials and optimization of the resulting heterogeneous interfaces still represent bottlenecks towards NIB commercialization.

In this contribution, we consider the highly-sodiated P2- $\text{Na}_{0.75}\text{Ni}_{0.25}\text{Mn}_{0.75}\text{O}_2$  (NNMO) oxide and the PyrFSI room-temperature ionic liquid (RTIL) as case studies for a theoretical investigation of a realistic cathode/electrolyte NIB interface [2].

By applying state-of-the-art computational methods based on Density Functional Theory (DFT), we aim at elucidating to what extent structural and electronic features of such interface are affected upon charge/discharge cycling, i.e. at different cathode sodiation stages. Stability and then interaction with PyrFSI of several possible terminations exposed on the cathodic surface is first explored by analyzing the (001) and (100) crystal facets [3]. The main interactions and adsorption energetics unveiled from first principles for the NNMO/PyrFSI model systems are key to set up advanced dynamics simulations aimed at tackling the evolution of electrochemical interfaces over time.

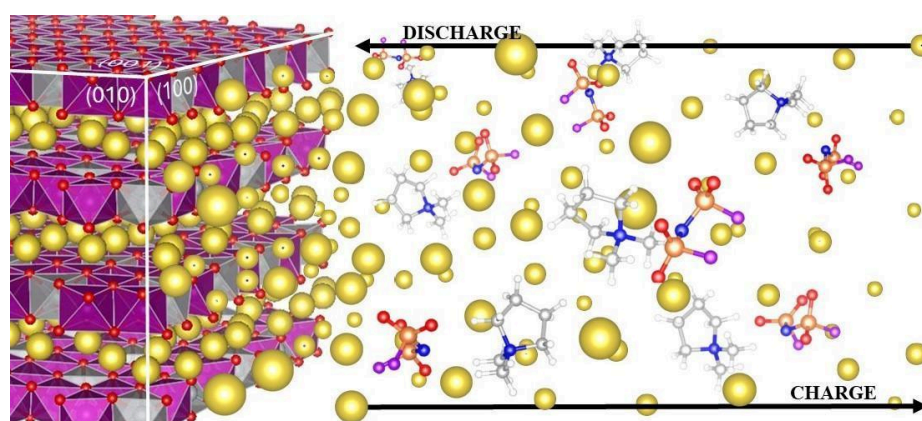

**Figure 1** Pictorial representation of P2- $\text{Na}_x\text{Ni}_{0.25}\text{Mn}_{0.75}\text{O}_2$ /PyrFSI interfaces

[1] W. Zuo, A. Innocenti, M. Zarrabeitia, D. Bresser, Y. Yang and S. Passerini, *Acc. Chem. Res.* Ed. 56 (2023) 284-296

[2] K. Sirengo, A. Babu, B. Brennan and S. C. Pillai, *J. Energy Chem.* 81 (2023) 321-338

[3] R. Tesch and R. M. Kowalski, *Phys. Rev.* 105 (2022) 195153

## Structural and electronic features of Prussian Blue analogues for application in energy storage devices

Manuel Emanuele,<sup>a,c</sup> Arianna Massaro,<sup>a,c</sup> Ana Belen Muñoz-García,<sup>b,c</sup> and Michele Pavone<sup>a,c</sup>

<sup>a</sup> Department of Chemical Sciences, University of Naples Federico II, Via Cintia 26, 80126 Naples, Italy

<sup>b</sup> Department of Physics "Ettore Pancini", University of Naples Federico II, Via Cintia 26, 80126 Naples, Italy

<sup>c</sup> Consorzio Interuniversitario Nazionale per la Scienza e Tecnologia dei Materiali (INSTM), via Guseppe Giusti 9, 50121 Florence, Italy

E-mail: [ma.emanuele@studenti.unina.it](mailto:ma.emanuele@studenti.unina.it)

Post-lithium energy storage technologies promise to meet the targets of a safer and more sustainable future electric market [1], increasingly replacing the pioneering Li-ion batteries (LIBs), which have dominated the field for decades but present the scarcity and uneven distribution of Lithium as critical issue [2]. Among others, Na-ion batteries (NIBs) and K-ion batteries (KIBs) are on the spotlight thanks to similar electrochemical principles to LIBs, but with larger ionic radius of both Na<sup>+</sup> and K<sup>+</sup> calling for different active components. Herein, we investigate Prussian Blue and its analogues (PB and PBAs), which gained attention as potential NIB and KIB cathode materials due to their metal-organic frameworks-like crystal structures, which offer suitable cavity sites to accommodate Na<sup>+</sup> and K<sup>+</sup> [3]. In particular, we use Ab-initio calculations as a powerful tool to unravel PB and PBAs microscopic features governing their electrochemical behaviour upon cycling. We dissect structural, electronic and magnetic properties and changes upon charge/discharge (*i.e.*, sodiation/desodiation and potassiation/ depotassiation) and explore the charge compensation mechanisms at different Na/K contents. Our theoretical insights on the evaluation of cathode composition, metal doping effects and defectivity pave the route towards obtaining rational design principles of new efficient and stable electrode materials for NIBs and KIBs.

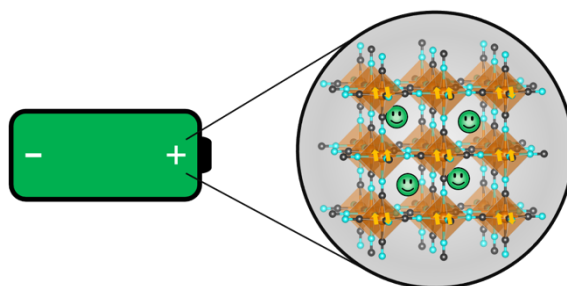

**Figure 1:** Pictorial representation of Na<sub>x</sub>Fe[Fe(CN)<sub>6</sub>] cathode.

[1] S. Ferrari, M. Falco, Ana B. Muñoz-García, M. Bonomo, S. Brutti, M. Pavone and C. Gerbaldi, *Adv. Energy Mater* (2021) 1614-6832

[2] M. Armand, and J.M. Tarascon, *Nature* (2008) 652-657

[3] Y. You, X.-L. Wu, Y.-X. Yin, and Y.-G. Guo, *Energy Environ. Sci.* (2014) 1643-1647

## First-principles study of perovskite oxide for solid oxide electrochemical cells: effects of stress/strain on ion transport in $\text{Sr}_2\text{Fe}_{1.5}\text{Mo}_{0.5}\text{O}_{6-\delta}$

Sara Balocco,<sup>a</sup> Arianna Massaro,<sup>b,c</sup> Ana Belén Muñoz-García,<sup>a,c</sup> and Michele Pavone<sup>b,c</sup>

<sup>a</sup> Department of Physics “E. Pancini”, University of Naples Federico II, Via Cintia 26, 80126 Naples, Italy

<sup>b</sup> Department of Chemical Sciences, University of Naples Federico II, Via Cintia 26, 80126 Naples, Italy

<sup>c</sup> Consorzio INSTM, Via Giuseppe Giusti 9, 50121 Florence, Italy

E-mail: [sara.balocco@unina.it](mailto:sara.balocco@unina.it)

Solid oxide fuel cells (SOFCs) represent a promising technology for clean and efficient power generation from  $\text{H}_2$  and  $\text{O}_2$  fuels and leading to  $\text{H}_2\text{O}$  as the only product. When operated in reverse mode, solid oxide electrolyzer cells (SOECs) could be very effective for the water splitting process and  $\text{H}_2$  storage[1]. Efficient transport of oxygen ions and electrons through state-of-the-art solid-state electrolytes and electrodes is presently accessible at very high temperatures, which on the other side lead to slow startup times and accelerate material degradation. Electrode materials that can be operated at lower temperatures are highly pursued to achieve sustainable devices, one example being the mixed ion-electron conductors (MIECs) [2]. Perovskite oxides are promising electrodes for oxygen evolution/reduction reactions (OER/ORR), the efficiency of the two opposite reactions being usually largely different. In this context,  $\text{Sr}_2\text{Fe}_{1.5}\text{Mo}_{0.5}\text{O}_{6-\delta}$  (SFMO) perovskite has gained attention as a potentially bifunctional system. Following a previous study carried out in our group [3], we address the structural and electronic features and their effect on the two main processes governing ionic diffusion: (i) oxygen vacancy ( $V_{\text{O}}$ ) formation; (ii)  $V_{\text{O}}$ -mediated migration. We evaluate these detailed mechanisms upon applied stress and strain, which specifically simulate the interfacial adaptation of SFMO in the device. Our DFT+U results will shed light on the ion transport mechanisms at the atomic scale, thus providing rational strategies towards the design and development of efficient systems.

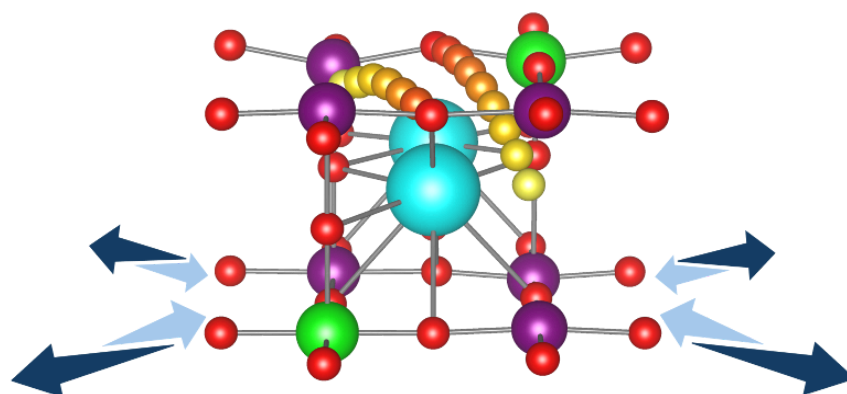

**Figure 1:** Pictorial representation of  $V_{\text{O}}$ -mediated migration in  $\text{Sr}_2\text{Fe}_{1.5}\text{Mo}_{0.5}\text{O}_{6-\delta}$

[1] A. Vojvodic, and J. K. Nørskov, *Science* 334 (2011) 1355-1356

[2] A. B. Muñoz-García, A. M. Ritzmann, M. Pavone, J. A. Keith, and E. A. Carter, *Acc. Chem. Res.* 47 (2014) 3340-3348

[3] A. B. Muñoz-García, and M. Pavone, *J. Mater. Chem. A* 5 (2017) 12735

**Nanoscale capacitance spectroscopy with a multi-frequency electrostatic force microscopy-based approach to measure energy materials**

Pascal N. Rohrbeck,<sup>a</sup> Lukas Drago Cavar,<sup>a,b</sup> and Stefan A. L. Weber,<sup>a,b,c</sup>

<sup>a</sup> *Max Planck Institute for Polymer Research, Department Physics at Interfaces, Ackermannweg 10, 55128 Mainz, Germany*

<sup>b</sup> *Johannes Gutenberg University, Department of Physics, Staudingerweg 10, 55128 Mainz, Germany*

<sup>c</sup> *Institute for Photovoltaics, University of Stuttgart, Pfaffenwaldring 47, 70569 Stuttgart, Germany*

*E-mail: [rohrbeckp@mpip-mainz.mpg.de](mailto:rohrbeckp@mpip-mainz.mpg.de)*

The knowledge of capacitance and dielectric properties in the nanoscale is important to understand the basic physics of semiconductor materials found to be in devices such as solar cells or battery materials [1].

In this work, we present a new mode to qualitatively measure the local and second capacity gradient of individual nanostructures using an Atomic Force Microscope (AFM). The new Nanoscale Capacitance Spectroscopy method is based on frequency mixing of two alternating current (AC)-voltages with frequencies in the MHz range. This new method enables qualitative measurements of tip-sample capacitance with the lateral resolution of the AFM. We can show that the Nanoscale Capacitance Spectroscopy method reduces the effect of stray capacitance and thereby yields superior lateral resolution.

[1] Fumagalli, L.; Ferrari, G.; Sampietro, M.; Gomila, G. *Applied Physics Letters* 2007, 91(24), 236243110.  
doi:10.1063/1.2821119

## Bamboo charcoal electrodes for vanadium redox flow batteries

Monja Schilling,<sup>a</sup> Rafaela Debastiani,<sup>b,c</sup> Alexey Ershov,<sup>d</sup> Kangjun Duan,<sup>a</sup> Kerstin Köble,<sup>a</sup> Simon Scherer,<sup>a</sup> Linghan Lan,<sup>e</sup> Alexander Rampf,<sup>a</sup> Tomáš Faragó,<sup>d</sup> Marcus Zuber,<sup>d</sup> Angelica Cecilia,<sup>d</sup> Shaojun Liu,<sup>a,f</sup> Cheng Liu,<sup>a,f</sup> Tilo Baumbach,<sup>d,g</sup> Jun Li,<sup>e</sup> Pang-Chieh Sui,<sup>f</sup> and Roswitha Zeis<sup>a,h,i</sup>

<sup>a</sup> Karlsruhe Institute of Technology, Helmholtz Institute Ulm, Ulm, Germany

<sup>b</sup> Karlsruhe Institute of Technology (KIT), Institute of Nanotechnology, Karlsruhe, Germany

<sup>c</sup> KIT, Karlsruhe Nano Micro Facility, Karlsruhe, Germany

<sup>d</sup> KIT, Laboratory for Applications of Synchrotron Radiation, Karlsruhe, Germany

<sup>e</sup> Key Laboratory of Low-Grade Energy Utilization Technologies and Systems, Chongqing University, Chongqing, China

<sup>f</sup> Wuhan University of Technology, School of Automotive Engineering, Wuhan, China

<sup>g</sup> KIT, Institute for Photon Science and Synchrotron Radiation, Karlsruhe, Germany

<sup>h</sup> Friedrich-Alexander-Universität Erlangen-Nürnberg, Faculty of Engineering, Department of Electrical, Electronics, and Communication Engineering, Erlangen, Germany

<sup>i</sup> Department of Mechanical & Industrial Engineering, University of Toronto, Toronto, Canada  
E-mail: monja.schilling@kit.edu

New energy storage devices are needed to balance the fluctuations of renewable energy sources. The Vanadium Redox Flow Battery (VRFB) is a strong candidate for large-scale energy storage devices. However, this battery type must increase lifetime and efficiency to succeed commercially. Polarization and pumping losses due to the high flow-through resistance of the electrolyte contribute to significant efficiency losses. Thus, the electrodes must be optimized regarding the catalytic activity and the flow properties to enhance the battery's efficiency. At the same time, the search for abundant and renewable raw materials for electrode fabrication is crucial. Bamboo offers a perfect solution due to its rapid growth, abundance, and internal 3D channel structure [1]. In this study [2], we investigate the performance of bamboo charcoal used as electrode material in VRFBs. The materials were characterized using  $\mu$ -computed tomography and scanning electron microscopy to investigate their 3D structure. Furthermore, we evaluated these materials using electrochemical techniques, including electrochemical impedance spectroscopy coupled with the distribution of relaxation times analysis [3] and cyclic voltammetry. Dynamic vapor sorption and synchrotron X-ray imaging experiments were conducted to assess the wettability.

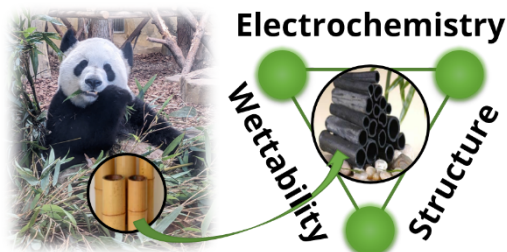

[1] W. Yang, J. Li, L. Zhang, X. Zhu, Q. Liao, *RSC Adv.* 2017, 7 (45), 28469–28475.

[2] M. Schilling, A. Ershov, R. Zeis, et al. *Energy Adv.* 2024, 3(5), 997–1008.

[3] M. Schilling, M. Braig, K. Köble, R. Zeis, *Electrochimica Acta* 2022, 430, 141058.

**Microfluidic-assisted fabrication of biomimetic hybrid liposomes for improved targeted delivery and antitumor efficacy in glioblastoma cells**

Ilaria Arduino<sup>1</sup>, Rosa Maria Iacobazzi<sup>1</sup>, Roberta Di Fonte<sup>2</sup>, Federica Sommonte<sup>2</sup>, Angela Assunta Lopodota<sup>1</sup>, Letizia Porcelli<sup>2</sup>, Amalia Azzariti<sup>2</sup>, Nunzio Denora<sup>1</sup>

<sup>1</sup> Department of Pharmacy–Pharmaceutical Sciences, University of Bari, 70125 Bari, Italy

<sup>2</sup> IRCCS Istituto Tumori “Giovanni Paolo II”, 70124 Bari, Italy

ilaria.arduino@uniba.it

The treatment of glioblastoma faces significant challenges primarily due to the blood-brain barrier (BBB) and the rapid immune clearance of drugs, underscoring the urgent need for advanced delivery systems. [1] This study aims to investigate an innovative drug delivery method using paclitaxel and carboplatin encapsulated in specially bioengineered liposomes. By incorporating cell membrane (CM) fragments extracted from a glioblastoma cell line into the liposomes, we aimed to endow them with stealth properties, improve their targeting efficiency, and enable them to evade immune detection. This modification allows the liposomes to accumulate in tumours through homotypic targeting preferentially. Microfluidic technique was employed to produce these biohybrid liposomes (Figure 1), namely we developed a microfluidic sonication method that integrates active and passive mixing techniques to enhance nanoparticle production efficiency. [2] Specifically, we employed two approaches: 1) using a single device placed in a sonicator bath for cell membrane (CM) breakdown, and 2) using two devices in series, where device 1 was placed in a sonicator bath for CM breakdown and device 2 was used for nanoparticle (NP) formation. To assess hybridization and confirm successful membrane fusion, we performed Förster resonance energy transfer, colocalization studies by flow cytometry, and Western blotting techniques. In vitro studies confirmed that these biomimetic hybrid liposomes can effectively target tumors, cross the BBB, and maintain the efficacy of paclitaxel and carboplatin. This novel delivery system offers a promising non-invasive approach for glioblastoma treatment, potentially eliminating invasive procedures to achieve effective drug delivery across the BBB.

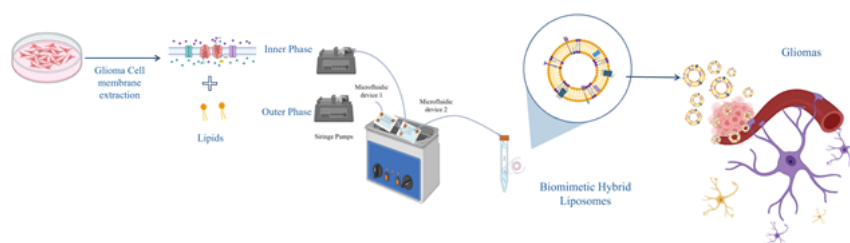

Figure 1: Scheme of the microfluidic production of biomimetic hybrid liposomes.

[1] Zhang G, et al. Application of cell membrane-functionalized biomimetic nanoparticles in the treatment of glioma. Journal of Materials Chemistry B. 2023;11(30):7055.

[2] Arduino I. et al. Microfluidic development and biological evaluation of targeted therapy-loaded biomimetic nanosystem to improve the metastatic melanoma treatment. International Journal of Pharmaceutics 2024, 25;650:123697.

## Functionalized radicals as up to date system for quantum technologies

Ambra M. Fiore<sup>a</sup>, Angela Punzi<sup>a</sup>, Davide Blasi<sup>a</sup>, Gianluca M. Farinola<sup>a</sup>

<sup>a</sup>Department of Chemistry, University of Bari, Via Orabona 4, 70125 - Bari, Italy

E-mail: [ambra.fiore@uniba.it](mailto:ambra.fiore@uniba.it)

Quantum information science (QIS) represents a fascinating and rapidly developing area in a multidisciplinary field that explores principles, applications etc. of quantum mechanics. The quantum analogues of classical bits are qubits which are enabled to exist at the same time in multiple states. Molecular qubits have distinct advantages of a wider control of spin properties by chemical synthesis and assembly [1]. In this context, polychlorinated triphenyl methyl radicals (PTMs), have been deeply studied in several fields. While it is well known their relevance in the field of organic optoelectronics [2], the possibility to use such derivatives as molecular q-bits is currently a hot topic. However, the synthesis of functionalized PTM derivatives is a challenging task, mainly due to the low reactivity of *para*-chlorinated positions. Recently, we focused on new strategies for the synthesis of easily functionalized mixed-halide trityl radicals and on the possibility to tune the electro-optical properties of inert trityl radicals *via* polyfluorination [3].

In this context, we are currently working on the synthesis of new D-A derivatives exploiting the higher reactivity of polyfluorinated systems in nucleophilic aromatic substitution. This approach holds promise to considerably simplify the synthesis of functionalized inert radicals which can find application in several fields, including quantum technologies as new molecular q-bits.

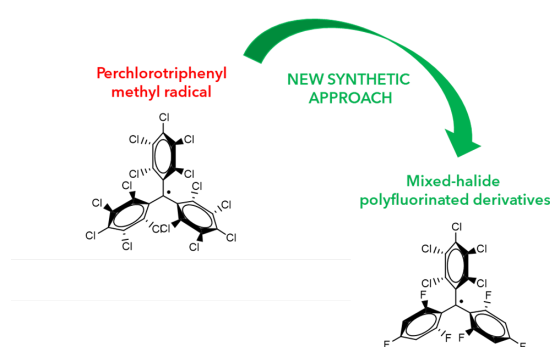

**Fig. 1** Schematic representation of the new synthetic approach for new q-molecular materials

Acknowledgements: This research acknowledges support from the Project National Quantum Science and Technology Institute (PE4 – Science e tecnologie quantistiche) CUP of project H93C220006700006) PNRR\_PE\_30.

[1] M. Maylander, K. Kopp, O. Nolden, M. Franz, P. Thielert, A.V. Jentzsch, P. Gilch, O. Schiemann, S. Richert, *Chem. Sci.* 14, (2023) 10727

[2] X. Ai, E.W. Evans, S. Dong, A.J. Gillett, H. Guo, Y. Chen, T.J.H. Hele, R.H. Friend, F. Li, *Nature* 563(2018) 536-540

[3] D. Mesto, Y. Dai, C. Dibenedetto, A. Punzi, J. Krajčovič, M. Striccoli, F. Negri, D. Blasi, *EurJOC* 26 (2023) e202201030

## From waste to functional resource: unveiling the performance of 3D printable peanut shell-filled polymer composites for food packaging applications

Matteo Sambucci,<sup>a,b</sup> Rosa Rita Esposito,<sup>c</sup> Irene Bavasso,<sup>a,b</sup> Giulia Cavallaro,<sup>c</sup> Stefano Capezzone,<sup>c</sup> Fabrizio Sarasini,<sup>a,b</sup> and Jacopo Tirillò,<sup>a,b</sup>

<sup>a</sup> Department of Chemical Engineering, Materials, Environment, Sapienza University of Rome, Via Eudossiana 18, 00184, Rome, Italy

<sup>b</sup> INSTM Reference Laboratory for Engineering of Surface Treatments, UdR Rome, Sapienza University of Rome, 00184 Rome, Italy

<sup>c</sup> Chirale S.r.l., Via Ignazio Persico 32, 00154 Rome, Italy

E-mail: [matteo.sambucci@uniroma1.it](mailto:matteo.sambucci@uniroma1.it)

The incorporation of bio-based fillers as reinforcing agents in polymeric matrices to produce bio-composites tailored for 3D printing processes is an attractive strategy towards the design of advanced and eco-friendly materials in the food packaging industry. These bio-filled polymeric materials have many benefits like biodegradability, economical, CO<sub>2</sub> emission balancing, and good quality in strength for packaging applications [1]. Additive manufacturing has the potential to enable optimized and smart fabrication in the packaging industry reducing the costs of the final food products [2]. The present work addressed the development of PLA-based filaments low-filled with peanut shell powder for the design of 3D printed packaging structures intended for fresh food preservation. First, the research involved the manufacturing of the filaments and the optimization of printing parameters for Fused Deposition Modeling (FDM) technology. Then the thermal and mechanical properties of the 3D printed composites were evaluated. Finally, prototypal bio-packaging boxes were fabricated evaluating their preservation capabilities by shelf-life testing on fresh fruit (Figure 1).



**Figure 1:** Bio-packaging boxes incorporating peanut shell powder for fresh fruit preservation.

Acknowledgements. Thanks are due to the Circular and Sustainable Made in Italy Extended Partnership (MICS) funded by the European Union Next-Generation EU (Piano Nazionale di Ripresa e Resilienza (PNRR) - Missione 4, Componente 2, Investimento 1.3 - D.D. 1551.11-10-2022, PE00000004) for financial support.

[1] N. Mathiazhagan, N.K. Sivakumar, S. Palaniyappan, and M. Rahaman, *J. Thermoplast. Compos. Mater.* 37(2) (2024) 713-742

[2] S. Palaniyappan, N.K. Sivakumar, M. Bodaghi, M. Rahaman, and S. Pandiaraj, *Food Packaging Shelf* 41 (2024) 101226

## Enhancing recyclability of epoxy resins through mechanochemical functionalization

Angela Marotta, Marco Agizza, Martina Salzano de Luna, Giovanni Filippone, Veronica Ambrogi

*Department of Chemical, Materials and Production Engineering (DICMaPI), University of Naples Federico II,  
P.le Tecchio 80, 80125, Napoli, Italy  
E-mail: angela.marotta@unina.it*

Attention to the environmental effect of all human activities, particularly sustainability, is central to political agendas, company strategies, and contemporary scientific study. In fact, in 2020, the European Commission released an action plan for a novel circular economy, including guidelines for designing more sustainable goods and reducing waste [1]. The circular economy is a production and consumption paradigm promoting the reuse, repair, restoration, and recycling of existing resources and items for as long as possible, hence extending product life cycles.

Thermosetting materials, like epoxy resins, fail to fit into the framework of a circular economy since they do not melt and have excellent mechanical and chemical durability due to their covalently crosslinked structure. However, the scientific community identified a solution to this problem through the development of so-called Covalent Adaptable Networks (CANs): materials having a three-dimensional network consisting of dynamic covalent bonds that can be broken and restored in response to a specific stimulus [2]. In this approach, certain well-designed thermosets may be remolded, repaired, and reused in accordance with circular economy requirements.

Another issue that remains unresolved is the massive volume of epoxy resins that were previously made and dispersed globally. Fortunately, this issue may be remedied through the use of CANs. The addition of appropriate compounds (e.g., catalysts) to unrecyclable epoxy resins by different methods, such as reactive blending, mechano-chemical functionalization, or infusion, might guarantee the reprocessability of a significant number of materials that currently exist [3].

Among these techniques, mechanochemical functionalization allows the incorporation of the appropriate additives without the need for a solvent, transforming standard epoxy resins into ones that can then be processed again.

[1] [https://ec.europa.eu/commission/presscorner/detail/it/ip\\_20\\_420](https://ec.europa.eu/commission/presscorner/detail/it/ip_20_420)

[2] C.J. Kloxin, C.N. Bowman. *Chem. Soc. Rev.* 42 (2013) 7161-7173

[3] L. Yue, V.S. Bonab, D. Yuan, A. Patel, V. Karimkhani, I. Manas-Zloczower. *Global Chall.* 3 (2019) 1800076

## Structure-Based Discovery of Inhibitors of the SARS-CoV-2 Nsp14 N7-Methyltransferase

Isabella Romeo,<sup>a</sup> Gianmarco Gualtieri,<sup>a</sup> Margarida Saramago,<sup>b</sup> Rute Matos,<sup>b</sup> and Stefano Alcaro<sup>a</sup>

<sup>a</sup> *Department of Health Sciences, Università degli Studi “Magna Græcia” di Catanzaro, Campus “S. Venuta”, Viale Europa, 88100 Catanzaro, Italy*

<sup>b</sup> *Instituto de Tecnologia Quimica e Biologica Antonio Xavier, Universidade Nova de Lisboa, Av. da Republica, 2780-157 Oeiras, Portugal  
E-mail: isabella.romeo@unicz.it*

The SARS-CoV-2 virus has sparked a global pandemic with severe consequences, making an understanding of its fundamental aspects critically important. In this study, we focused on the viral ribonuclease nsp14, one of the key interferon antagonists in SARS-CoV-2. Nsp14 is a multifunctional protein with two distinct activities: an N-terminal 3'-to-5' exoribonuclease (ExoN) and a C-terminal N7-methyltransferase (N7-MTase), both essential for the coronavirus life cycle. This dual function highlights nsp14 as a prime target for antiviral drug development [1]. Here, we conducted a structure-based virtual screening of a natural compound library comprising approximately 96,400 achiral compounds, collected in COCONUT Database, aiming to identify novel inhibitors of the SARS-CoV-2 methyltransferase. Among the promising compounds, ten of them were purchased and tested for their ability to block Nsp14 activities. One compound resulted able to interfere with MTase activity. Structurally, this *hit* is a non-SAM-like structure, providing promising starting point for future optimization to find new class of Nsp14 inhibitors.

[1] N.S. Ogando, P. El Kazzi, J.C. Zevenhoven-Dobbe, B.W. Bontes, A. Decombe, C.C. Posthuma, V. Thiel, B. Canard, F. Ferron, E. Decroly, E.J. Snijder, *Proc Natl Acad Sci U S A.* (2021) 118:e2108709118.

## The electron–proton bottleneck of photosynthetic oxygen evolution

Paul Greife <sup>a,d</sup>, Matthias Schönborn <sup>a,d</sup>, Matteo Capone <sup>b,c,d,f</sup>, Ricardo Assunção <sup>a</sup>,  
Daniele Narzi <sup>c</sup>, Leonardo Guidoni <sup>c</sup> and Holger Dau <sup>a</sup>

<sup>a</sup>Department of Physics, Freie Universität, Berlin, Germany

<sup>b</sup>Department of Information Engineering, Computer Science and Mathematics, University of L'Aquila,  
L'Aquila, Italy

<sup>c</sup>Department of Physical and Chemical Sciences, University of L'Aquila, L'Aquila, Italy

<sup>d</sup>These authors contributed equally

<sup>f</sup> current affiliation: S3 Center, CNR Institute of Nanoscience, Modena, Italy

E-mail: [matteo.capone@nano.cnr.it](mailto:matteo.capone@nano.cnr.it)

The light-driven water oxidation reaction is the core process of photosynthesis, responsible for converting light energy into chemical energy stored in plant tissues. Despite decades of research, the mechanism remains incompletely understood due to its complexity.

We were able to clarify the chemical nature of the "bottleneck" in the water oxidation process, using time-resolved infrared spectroscopy and quantum/classical multiscale molecular dynamics simulations. In particular, we identified the final step of the reaction, catalyzed by the manganese cluster in Photosystem II, as the slowest. Before the formation of the peroxide bond (precursor to the oxygen molecule), two protons must be removed from the reaction center. This step involves the reorientation of a large network of hydrogen bonds over several dozen ångströms, creating a substantial entropic barrier.

Our simulations, for the first time, pinpointed the complex hydrogen bond network and the preferential proton pathway required for this event. The results were confirmed by the excellent match between the enthalpic contribution of the barrier and experimental measurements. Understanding this rate-limiting step is key to advancing our knowledge of photosynthetic kinetics and provides a foundation for progress in artificial photosynthesis, an important topic for the development of sustainable energy solutions.

[1] Greife, P., Schönborn, M., Capone, M., Assunção, R., Narzi, D., Guidoni, L., & Dau, H. (2023). The electron–proton bottleneck of photosynthetic oxygen evolution. *Nature*, 617(7961), 623–628.

**Singlet-Triplet Energy Inversion in Carbon Nitride Photocatalysts**

Arianna Actis,<sup>a</sup> Michele Melchionna,<sup>b</sup> Giacomo Filippini,<sup>b</sup> Paolo Fornasiero,<sup>b</sup> Maurizio Prato,<sup>b</sup> Mario Chiesa,<sup>a</sup> and Enrico Salvadori<sup>a</sup>

<sup>a</sup> *Department of Chemistry and NIS Centre, Università degli Studi di Torino, Via P. Giuria 7, 10125-Turin, Italy*

<sup>b</sup> *Department of Chemical and Pharmaceutical Sciences, Università degli Studi di Trieste, Via L. Giorgieri 1, 34127-Trieste, Italy*

*E-mail: arianna.actis@unito.it*

Photocatalysts constituted by earth-abundant inexpensive elements and with good absorption properties in the visible are key to foster a greener photochemistry. Carbon nitride (CN) is a bi-dimensional semiconductor which has raised much interest over the past few years because it possesses all these features. However, due to rapid charge-carrier recombination, its efficiency is usually low. Furthermore, CN is a solid-state material with a poorly defined structure and catalytic properties that strongly depend on its morphology. Therefore, in order to improve its performances, a thorough understanding of the mechanisms underlying light harvesting and conversion into charge carriers and how these are related to the morphology of the material is crucial. In particular, a number of studies have highlighted an empirical correlation between the catalytic efficiency and the number of native and photoinduced paramagnetic species present in the material [1].

Among the common studies on the photophysics of CN, the nature and role of excited triplet excitons has not yet been fully investigated. In this contribution, I will present the characterization of the metastable photo-excited triplet excitons by means of time-resolved EPR [2]. The present study probes the existence of triplet excitons in CN, derives their energy and investigates the dependence of their properties on the morphology of the material. In order to ensure that such results are an intrinsic feature of polymeric CN, a comparison with the heptazine-based monomer and a series of heptazine oligomers is performed.

This work showcases how EPR methods allow i) to cover the temporal range corresponding to the time scale compatible with chemical reactivity and; ii) to track the evolution of paramagnetic species formed upon photoexcitation in a complex and polycrystalline semiconductor. The experimental evidence obtained through EPR spectroscopy is complemented by optical spectroscopy data to compile comprehensive energy level diagrams that help explain the characteristic behaviour observed in working photocatalysts.

[1] Actis A., Fornasiero P., Chiesa M., Salvadori E., *ChemPhotoChem*, 2023, e202300203

[2] Actis A., Melchionna M., Filippini G., Fornasiero P., Prato M., Chiesa M., Salvadori E., *Angew. Chem. Int. Ed.*, 2023, 62, 48, e202313540



---

## Sponsors talks

SP01 – ONGARO Michael (Merck)

SP02 – GUGLIUCCI Wanda (Eni)

SP03 – ROSSETTI Arianna (INSTM)

SP04 – Claudia Bonfio (EYCN)

SP05 - CASULA Elis (Fluorsid)

SP06 - ROMANO Assunta (Merck)

---

## SP01

### **Merck Life Science: who we are and what we do**

Michael Ongaro

*Account Manager, Academia Government Hospital, Merck Life Science, Italy*

*E-mail: michael.ongaro@merckgroup.com*

As a vibrant science and technology company, we believe in science as a force for good. Our passion for science and technology is what drives our 64.220 employees across 66 countries to find solutions to some of today's toughest challenges and create more sustainable ways to live. Our tools, services, and digital platform make research simpler, more exact, and help to deliver breakthroughs more quickly.

---

## SP02

### Agri-bioenergy

Wanda Gugliucci<sup>a</sup>, Irene Rapone<sup>a</sup>, Thomas Pasini<sup>a</sup>, Paolo Pollesel<sup>a</sup>

<sup>a</sup> ENI - Renewable, New Energies and Material Science Research Center (DE-R&D), Via Fauser 4, 28100, Novara, Italy

E-mail: [wanda.gugliucci@eni.com](mailto:wanda.gugliucci@eni.com)

“One of the main Eni’s strategies is to decarbonize all products and supply chains by 2050, in this context biofuels have a key role to play in reducing the transport sector emissions.

The Eni biofuel supply chain is a virtual example of vertical integration starting from the cultivation of sustainable oil-seed crops on degraded soils to the oil extraction and biofuel production.

The oil from the seeds is extracted by different methods including mechanical pressing and solvent extraction. Hence, the oils are shipped to Eni biorefineries and treated through the ECOFINING™ process to produce HVO-fuels.

To respect the sustainability and circular economy principles all the residues are recycled. The solid residues obtained after the oil extraction from oil-crop seeds are rich in proteins, organic carbon, minerals and high-value compounds, which could be valorized in animal feeding and fertilizers sectors as well as for biochar production through pyrolysis.”

---

## SP03

### The contribution of academic research in the science and technology of materials: the INSTM network

Arianna Rossetti,<sup>a,e</sup> Angela Marotta,<sup>b,e</sup> Fabio Pizzetti,<sup>a,e</sup> Matteo Sambucci,<sup>c,e</sup> Claudia Sergi,<sup>c,e</sup> and Andrea Caneschi<sup>d,e</sup>

<sup>a</sup> Department of Chemistry, Materials, and Chemical Engineering "G. Natta", Politecnico di Milano, via Mancinelli 7, 20131, Milan - Italy

<sup>b</sup> Department of Chemical, Materials and Production Engineering – DICMaPI, University of Naples Federico II, P.le Tecchio 80 - 80125 Naples, Italy

<sup>c</sup> Department of Chemical Engineering, Materials, Environment, Università degli Studi di Roma La Sapienza, Via Eudossiana 18, 00184 Rome, Italy

<sup>d</sup> Department of Industrial Engineering (DIEF), University of Florence, Via della Lastruccia 3, 50019 Sesto Fiorentino (Fi) - Italy

<sup>e</sup> National Interuniversity Consortium of Materials Science and Technology (INSTM), Florence, Italy

E-mail: [arianna.rossetti@polimi.it](mailto:arianna.rossetti@polimi.it)

The INSTM (Italian National Inter-University Consortium for Materials Science and Technology) currently unites 52 Italian universities focused on research in advanced materials and related technologies. This consortium connects a network of over 3,000 individuals, including professors, researchers, research fellows, and PhD students. Research areas encompass health sciences, environmental science, nanotechnology, chemical engineering, and materials technology.

INSTM supports research activities within its member universities in the Materials Science and Technology field by offering organizational, technical, and financial assistance. The consortium fosters collaboration by organizing conferences and workshops, funding research fellowships and scholarships, and supporting applications for national and EU grants.

It also maintains partnerships and agreements with companies, research institutes, clusters, and innovation hubs across Europe, which will be highlighted.

---

## SP04

### What is the European Young Chemists' Network (EYCN)?

Claudia Bonfio,<sup>a</sup> Laura Alessandrini,<sup>b</sup> Matteo Bonomo,<sup>c,d</sup> Ambra Maria Fiore,<sup>e</sup> Sara Tortorella<sup>f</sup>

<sup>a</sup> *Department of Biochemistry, Sanger Building, University of Cambridge, 80 Tennis Court Road, CB2 1GA  
Cambridge UK*

<sup>b</sup> *School of Pharmacy, Chemistry Interdisciplinary Project (ChIP), University of Camerino, Via Madonna delle  
Carceri, 62032, Camerino, Italy*

<sup>c</sup> *Department of Basic and Applied Sciences for Engineering (SBAI), Sapienza University of Rome, via Castro  
Laurenziano, 7, 00161 Rome, Italy*

<sup>d</sup> *Department of Chemistry, NIS Interdepartmental Centre and INSTM Reference Centre, University of Turin,  
Via Giacchino Quarello 15/a, 10135 - Torino, Italy*

<sup>e</sup> *Department of Chemistry, University of Bari, Via Orabona 4, 70125 - Bari, Italy*

<sup>f</sup> *Molecular Horizon srl, Via Montelino 30, Bettona, PG 06084, Italy*

E.mail: chair@eycn.eu

The European Young Chemists' Network (EYCN) is the youth branch of EuChemS, representing young members from any EuChemS member society, based on their national criteria (view the full list here). These members automatically become part of the EYCN. Currently, the network has delegates and representatives across 22 countries, representing 25 chemical societies.

The EYCN's mission is to advance the field of chemistry in Europe while providing educational and networking opportunities for students and professionals. The network promotes various awards at conferences, organizes Career Days to develop soft skills, and supports exchange programs to enhance member mobility. To achieve these goals, the EYCN collaborates with industrial partners and other global young scientific societies.

The idea for the EYCN within EuChemS was first conceived during a series of young chemists' meetings in Europe. A key document, "Aims, Tasks and Goals of EYCN," was written at the 1st European Chemistry Congress in Budapest in 2006, establishing the foundation of the EYCN. In March 2007, Jens Breffke (Germany) and Csaba Janáky (Hungary) invited representatives from various societies to Berlin to formalize the EYCN's structure. Within just three weeks, the EuChemS Executive Committee approved these rules, officially recognizing the EYCN as the youth division of EuChemS.

## SP05

# LIFE-SYNFLUOR – Production of high purity synthetic calcium fluoride and precipitated silica using recovered fertilizer wastes

Elisa Casula

Fluorsid S.p.A., 2a Strada Macchiareddu, 09032 Assemini (CA), Italy  
[elisa.casula@fluorsid.com](mailto:elisa.casula@fluorsid.com)

The LIFE-SYNFLUOR project aims to validate an innovative technology, patented by Fluorsid [1], to produce high purity synthetic calcium fluoride and precipitated silica from a waste product from the fertilisers' industry, the hexafluorosilicic acid (FSA).

Acid grade fluorspar, with a minimum content of  $\text{CaF}_2$  of 97%, is mainly used to produce hydrofluoric acid, primary source of fluorochemicals such as aluminium fluoride, pharmaceuticals, polymers, etc, and for lithium-ion batteries. It has been included in the Critical Raw Material List by the UE since 2011. Precipitated silica improves the performance of rubber and plastic by acting as a reinforcing agent. Indeed, its major application is in the manufacturing of tires. Its traditional synthesis is significantly energy consuming. FSA has very limited applications, it is mostly disposed of at sea after neutralization, or dumped in desert areas, with serious danger for the health and environment.

The innovative process proposed by Fluorsid through the LIFE-SYNFLUOR project makes two valuable materials available with a limited consumption of natural resources, reducing the energy consumption, and solving the problem of a waste disposal. Through the construction and operation of a pilot plant, it is expected to produce 1000 tons of synthetic calcium fluoride, and 250 tons of precipitated silica starting from 2700 tons of FSA and 1000 tons of calcium hydroxide. To validate the technology, the synthetic calcium fluoride will be used as a substitute for natural fluorspar to produce hydrofluoric acid at the Fluorsid industrial site, while the precipitated silica will be used in the industrial production of prototype tyres.

If the technology and the sustainability of the process are demonstrated, the project will allow to reach a TRL8, making its full industrialization possible by creating circularity and synergies between three different industries: fertilizers, fluorochemicals and tires.

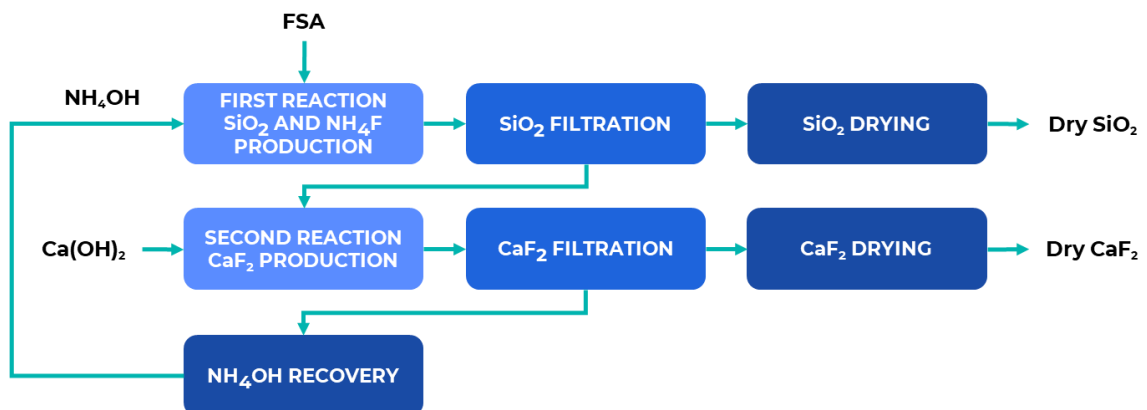

Figure 1: LIFE-SYNFLUOR process flow diagram.

[1] L. Pala, M. Lavanga *High Purity Synthetic Fluorite, Process for Preparing the Same and Apparatus Therefor*. WO2016/156969A1, 2016.

---

## SP06

### **Pioneering Progress: Commitment to Innovation & Sustainability**

Assunta Romano

*Segment Marketing Manager, Pharma Chemistry, Merck Life Science, WE*

*E-mail: [assunta.romano@merckgroup.com](mailto:assunta.romano@merckgroup.com)*

Pioneering progress at Merck KGaA, Darmstadt, Germany, is anchored in the vision of "Sparking Discovery, Elevating Humanity," which drives the organization's commitment to innovation and sustainability. This vision emphasizes the development of innovative solutions and new product introductions (NPI) that address global challenges in the fields of chemistry and life sciences.

Merck harnesses science and technology to create sustainable innovations that empower scientists to achieve their sustainability goals. By focusing on the impact of our technologies and products on health and well-being, we strive to minimize negative sustainability impacts across the entire product life cycle.

Innovative offerings, such as our Retrosynthesis software and new chemicals, exemplify how we provide solutions that advance scientific discovery while promoting sustainable practices in the industry. Through these initiatives, Merck is dedicated to making a meaningful impact on global health and sustainability.

---

## List of participants

<b>Name</b>	<b>Surname</b>	<b>University/Company</b>
Arianna	Actis	University of Turin
Federica	Alamia	University of Palermo
Federica	Alchera	University of Turin
Laura	Alessandroni	University of Camerino
Antonella I.	Alfano	University of Naples
Laura	Aliotta	University of Pisa
Andrea	Angelucci	Sapienza University of Rome
Giulia	Antonini	University of Milan
Ilaria	Arduino	University of Bari
M. Teresa	Armeli Iapichino	University of Catania
Ana	Arnaiz	University of Burgos
Carmela	Astorino	Polytechnic of Turin
Davide	Baldassin	University of Venice
Andrea	Baldi	University of Florence
Sara	Balocco	University of Naples Federico II
Simona	Barone	University of Naples Federico II
Francesca	Basso	Italian Institute of technology
Chiara	Battisegola	University of Naples Federico II
Federico	Bedogni	University of Bologna
Federico	Bella	Società Chimica Italiana
Tommaso	Benettin	University of Milan
Andrea	Bergomi	University of Milan
Bianca Laura	Bernardoni	University of Pisa
Francesco	Bertocchi	University of Parma
Denise	Biagini	University of Pisa
Chiara	Billi	University of Naples Federico II I
Claudia	Bonfio	University of Cambridgeaaaaaaa
Alessia	Bono	University of Palermo
Matteo	Bonomo	Sapienza University of Rome
Federica	Borghi	University of Modena-R. Emilia
Eleonora	Botter	University of Venice
Viviana	Bressi	University of Reggio Calabria
Giulia	Brioschi	University of Milan
Leonardo	Brunetti	University of Bari
Francesco	Busto	University of Bari

---

Pietro	Caboni	University of Cagliari
Camilla	Callegari	University of Pavia
Matteo	Capone	CNR Istituto Nanoscienze
David	Cappelletti	University of Padua
Martina	Carcagni	Polytechnic of Bari
Fabrizio	Careddu	University of Turin
Alessio	Carioscia	University of L'Aquila
Chiara	Carotti	Polytechnic of Milan
Lorenzo	Casoli	University of Rome Tor Vergata
Lorenza	Cassano	University of Pavia
Federico	Casti	University of Cagliari
Davide	Castiglione	University of Turin
Elisa	Casula	Fluorsid
Costantino	Cau	University of Sassari
Valeria	Cavalloro	University of Pavia
Sara	Cazzola	University of Padua
Andrea	Cerrato	Sapienza University of Rome
Rebecca	Ciani	University of Palermo
Wanda	Cimmino	University of Naples Federico II
Luigi	Cino	University of Palermo
Immacolata	Climaco	University of Naples Federico II
Alessio	Colleoni	University of Milan
E. Ignacio	Comas Iwasita	University of Turin
Michela	Cornale	University of Roma Tor Vergata
Samanta	Corsetti	University of Camerino
Giuseppe	Cosentino	University of Catania
Giuliana	Costanzo	University of Catania
Sara	Crosta	Polytechnic of Milan
Luisa	D'Anna	University of Palermo
Martina	D'Auria	University of Naples Federico II
Vanessa	Da Fermo	University of Chieti-Pescara
Marta	Da Pian	Elsevier
Ivan	Dacrema	National Ins. of Chem. Ljubljana
Anna	Dall'Anese	University of Trieste
Eugenio	De Nardo	Polytechnic of Turin
Simge Naz	Degerli	INSTM-University of Milan
Daniele	Del Giudice	Eindhoven Un. of Technology
Stefano	Di Giacomo	University of Chieti-Pescara
Giovanni	Di Liberto	University of Milan - Bicocca
Valentina	Di Matteo	University of Bologna

---

---

Manuele	Di Sante	University of Bologna
Serena	Ducoli	University of Brescia
G. Marco	Elisi	University of Urbino
Manuel	Emanuele	University of Naples Federico II
Giulia	Errichiello	University of Padova
Simone	Fabbian	University of Padua
Antonio	Faggiano	University of Salerno
En. Mario	Fassi	University of Milan
Alessandro		
Marco	Fattalini	University of Milano
Marianna	Fava	University of Siena
Giorgia	Ferraro	University of Venice
Ambra M.	Fiore	University of Bari
Anna	Fontana	University of Pavia
Charlotte	Fornaciari	University of Pavia
Alice	Fossati	University of Pavia
Marcello	Franzini	University of Turin
Chiara	Fratello	Sapienza University of Rome
Chiara	Frezza	University of Roma Tre
Marica	Gallo	University of Naples Federico II
Martina	Garbagnoli	University of Pavia
Andrea	Geri	University of Florence
Gabriele	Giagu	University of Bologna
Nicolò	Giulini	University of Milan - Bicocca
Alice	Gramegna	University of Milan
Rossella	Grappa	University of Naples Federico II
Andrea	Grillo	University of Naples Federico II
Marta	Guembe García	University of Burgos
Luca	Guglielmero	Scuola Normale Superiore
Wanda	Gugliucci	Eni S.p.A.
Carolin	Höner	Leibniz University Hannover,
Debora	Iapadre	University of L'Aquila
Elisabetta	Inico	University of Milan - Bicocca
Giulia M.	Itri	University of Perugia
Antonio	Jiritano	University of Calabria
Panagiota	Kalligosfyri	University of Naples, Federico II
Nicholas	Kassouf	University of Bologna
Gabriele	La Monica	University of Palermo
Zoe	Laface	University of Milan
Elena	Lenci	University of Florence

---

---

Chiara	Lenzi	University of Bologna
Elison	Lepore	University of Camerino
Silvia	Leveraro	University of Ferrara
Stefano	Liotino	University of Bari
Lisa	Lombardo	University of Messina
Chiara	Maccari	University of Parma
Daniel A.	Machado de Alencar	University of Turin
Lisa Rita	Magnaghi	University of Pavia
Pierfranc.	Maltoni	University of Genoa
Federica	Mancarella	University of Salento
Silvia	Marchesan	University of Trieste
Giulia	Marcolli	Polytechnic of Milan
Alessia	Marconi	University of Bologna
Lorenza	Marinaccio	University of Chieti-Pescara
Angela	Marotta	University of Naples Federico II
Sebastiano	Marra	University of Naples Federico II
Laura	Marretta	University of Palermo
Vittoria	Martini	University of Parma
Andrea	Masetti	University of Bologna
Arianna	Massaro	University of Naples Federico II
Federica	Matteucci	University of Camerino
Anna	Mauri	University of Insubria
Marco	Mendolicchio	Scuola Normale Superiore
Nicolò	Mercorelli	University of Bologna
Federica	Meringolo	University of Calabria
Antonella	Miglione	University of Naples Federico II
Matteo	Milanesi	Polytechnic of Turin
Giorgio	Milli	University of Pavia
Davide	Moi	University of Cagliari
M. Cristina	Molaro	University of Naples Federico II
Caterina	Momoli	University of L'Aquila
Luigi	Mondello	University of Messina
Carmela M.	Montone	University of Rome La Sapienza
Daniele	Motta	University of Turin
S.M. Sadeq	Mousavi	University of Salerno
Alberto	Nardi	University of Turin
Viviana	Nebbioso	University of Naples Federico II
Luca	Nespoli	University of Milan
Luca	Nicchio	University of Pavia
Ylenia	Nowak	CNR - ICCOM

---

---

Michael	Ongaro	Merck Life Science Srl
Silvia	Orecchio	University of Palermo
Giorgio	Pagano	University of Rome Tor Vergata
Elena T.	Palombella	University of Bari
Emilia	Paone	University of Reggio Calabria
Roberto	Pascucci	Merck Life Science
Donato	Pasculli	University of Turin
Sara	Pavone	University of Florence
Giovanni	Petrarolo	University of Pisa
Claudio	Pettinari	University of Camerino
Alessia	Piergentili	University of Camerino
Giovanna	Pitasi	University of Messina
Fabio	Pizzetti	Polytechnic of Milan
Marta	Plebani	ACS Publications
Eleonora	Previati	Polytechnic of Turin
Giulia	Quaglia	University of Perugia
Valentina	Quarta	University of Pavia
Giovanna	Raia	University of Palermo
Chiara	Reviglio	University of Turin
Grazia I.C.	Righetti	Polytechnic of Milan
Laura	Riva	Polytechnic of Milan
Luca	Rivoira	University of Torino
Pascal N.	Rohrbeck	MPIP Mainz
Assunta	Romano	Merck Life Science
Susanna	Romano	University of Roma Tre
Isabella	Romeo	University of Magna Graecia
Vincenzo	Roselli	University of Bari
Arianna	Rossetti	Polytechnic of Milan
Eleonora	Rossi	University of Bologna
Giacomo	Rossino	University of Pavia
Ludovica	Russo	University of Naples Federico II
Francesca	Sacchi	University of Milan
Clara	Saetta	University of Milan Bicocca
Giorgia	Salerno	University of Milan Bicocca
Stefano	Salmaso	University of Padova
Matteo	Sambucci	Sapienza University of Rome
Domenico	Santandrea	University of Campania
Claudia	Scappaticci	University of L'Aquila
M. Erminia	Schiano	University of Naples Federico II
Monja	Schilling	German Young Chemists Network

---

---

Hendrik	Schröder	Robert Bosch GmbH
Sara	Sciarretta	University of L'Aquila
Giorgia	Scorzoni	University of Bologna
Silvia	Sepich	Merck
Carmen	Serpico	University of Naples Federico II
Alessandra	Sessa	University of Salerno
Federica	Sodano	University of Naples Federico II
Andrea	Sodini	University of Florence
Vanessa	Spanò	University of Catania
Valeria	Sperati	Polytechnic of Turin
Matteo	Spotti	University of Milano-Bicocca
Sara	Stocchetti	University of Cagliari
Francesco	Taglieri	University of L'Aquila
Vincenzo	Tedeschi	University of Bari
Mattia	Tiboni	University of Urbino
Matteo	Tommasi	University of Milan
Giovanni	Tonon	University of Venice
Sara	Tortorella	Molecular Horizon
Gabriele	Travagliante	University of Catania
A. C. Pio	Trimboli	University of Reggio Calabria
Elisabetta	Tumminelli	University of Pavia
Lavanya	Veerapuram	University of Messina
Jacopo	Venditti	University of Siena
Virginia	Venezia	University of Naples Federico II
Gabriele	Viada	University of Turin
Valentina	Villamil	University of Modena R. Emilia
Flaminia	Vincenti	CNVVF
Valentina	Vitali	University of Florence
Stefano	Zineddu	University of Florence

---

## Società Chimica Italiana

Società Chimica Italiana (SCI) is a scientific association that includes more than 5000 members. It was founded in 1909 and erected as a Legal Institution with R.D. n. 480/1926. SCI members carry out their activities in universities, public and private research institutes, schools, industries, or as freelancers. They are joined not only by the interest in chemical sciences, but also by the desire to contribute to the cultural and economic growth of the national community, within a global framework, improving the quality of human life and the protection of the environment. SCI is organized in Divisions and Sections: Divisions are thematic branches, gathering members working in the same field or sharing the same scientific interests; Sections are local branches, gathering people working or living in the same territory.

### For new members

All the participants to the *Merck Young Chemists' SymposiumXXII edition* are (or are going to be) SCI members. Those who were not yet SCI members before the conference, must fill the request form included in the Conference bag in order to complete the membership procedure. Those who chose the 1-year subscription will be enrolled until 31/12/2024; those who chose the 2-year subscription will be SCI members up to the end of 2025.

---

## SCI Giovani / SCI Young

All SCI members younger than 35 years old belong to SCI Giovani, an interdisciplinary group organizing multiple initiatives precisely devoted to youngsters, such as prizes, workshops, and the very congress you are attending.



You can find all the information about these activities on our website

[https://www.soc.chim.it/sci\\_giovani/home](https://www.soc.chim.it/sci_giovani/home)

as well as on our social media pages



**We strongly suggest to actively take part to the initiatives proposed by SCI Giovani, since they constitute a fundamental opportunity to familiarize with the national and international scientific community, to experience new opportunities of personal and professional growth, and to boost your CV.**

---

## Sponsored by

---

### PLATINUM SPONSOR



---

### GOLD SPONSOR



---

### SILVER SPONSOR



---

### BRONZE SPONSORS



---

### IN COLLABORATION WITH

